

CHAPTER 17

UNSIGNALIZED INTERSECTIONS

CONTENTS

PREFACE..... 17-1
 Overview 17-1
 Limitations of the Methodology 17-1
PART A. TWO-WAY STOP-CONTROLLED INTERSECTIONS 17-1
I. INTRODUCTION - PART A..... 17-1
II. METHODOLOGY - PART A 17-1
 Level-of-Service Criteria..... 17-1
 Input Data Requirements 17-3
 Priority of Streams 17-3
 Conflicting Traffic..... 17-4
 Critical Gap and Follow-Up Time 17-5
 Potential Capacity 17-7
 Movement Capacity..... 17-8
 Impedance Effects 17-9
 Vehicle Impedance 17-9
 Pedestrian Impedance 17-11
 Shared-Lane Capacity 17-12
 Minor-Street Approaches 17-12
 Major-Street Approaches 17-13
 Upstream Signals..... 17-13
 Time to Clear Standing Queue - Computation 1 17-14
 Proportion of Time TWSC Intersection Is Blocked -
 Computation 2 17-15
 Platoon Event Periods - Computation 3..... 17-17
 Conflicting Flows During Unblocked Period - Computation 4 17-19
 Capacity During Unblocked Period - Computation 5 17-19
 Two-Stage Gap Acceptance 17-19
 Flared Minor-Street Approaches 17-21
 Estimating Queue Lengths 17-22
 Control Delay..... 17-23
 Other Relevant Delay Estimates 17-25
 Delay to Rank 1 Vehicles 17-25
 Intersection and Approach Delay 17-25
 Interpreting Results 17-26
 Shared Lanes 17-26
 Performance Measures..... 17-26
 Determining Intersection Control Type..... 17-27
III. APPLICATIONS - PART A 17-28
 Sequence of Capacity Computations 17-28
 Computational Steps 17-28
 Geometrics and Movements (Worksheet 1) 17-28
 Volume Adjustments (Worksheet 2)..... 17-28
 Site Characteristics (Worksheet 3)..... 17-28
 Critical Gap and Follow-Up Time (Worksheet 4) 17-30
 Effect of Upstream Signals (Worksheet 5)..... 17-30
 Impedance and Capacity Calculation (Worksheet 6)..... 17-30
 Two-Stage Gap Acceptance (Worksheet 7) 17-31

Shared-Lane Capacity (Worksheet 8)	17-31
Effect of Flared Minor-Street Approaches (Worksheet 9).....	17-31
Control Delay, Queue Length, Level of Service (Worksheet 10)	17-31
Delay to Rank 1 Vehicles (Worksheet 11)	17-31
Planning and Design Applications	17-31
PART B. ALL-WAY STOP-CONTROLLED INTERSECTIONS	17-32
I. INTRODUCTION - PART B	17-32
II. METHODOLOGY - PART B.....	17-32
Level-of-Service Criteria	17-32
Overview of Methodology	17-32
Capacity Model	17-34
Intersection of Two One-Way Streets.....	17-34
Intersection of Two Two-Way Streets.....	17-35
Generalized Model for Single-Lane Sites	17-35
Generalized Model for Multilane Sites	17-36
Control Delay	17-40
III. APPLICATIONS - PART B.....	17-40
Computational Steps.....	17-41
Geometrics and Movements (Worksheet 1)	17-41
Volume Adjustments and Lane Assignments (Worksheet 2).....	17-41
Saturation Headways (Worksheet 3)	17-42
Departure Headway and Service Time (Worksheet 4)	17-42
Worksheet 4a	17-42
Worksheet 4b	17-42
Capacity and Level of Service (Worksheet 5)	17-44
Planning and Design Applications	17-44
PART C. ROUNDABOUTS	17-45
I. INTRODUCTION - PART C	17-45
II. METHODOLOGY - PART C	17-45
Overview of Methodology	17-45
Capacity	17-46
III. APPLICATIONS - PART C.....	17-48
PART D. EXAMPLE PROBLEMS	17-49
Example Problem 1.....	17-50
Example Problem 2.....	17-57
Example Problem 3.....	17-67
Example Problem 4.....	17-77
Example Problem 5.....	17-86
Example Problem 6.....	17-99
REFERENCES	17-101
Part A - TWSC Unsignalized Intersections	17-101
Part B - AWSC Unsignalized Intersections	17-102
Part C - Roundabouts	17-102
APPENDIX A. WORKSHEETS	17-103
Part A - TWSC Unsignalized Intersections	
Worksheet 1 - Geometrics and Movements	
Worksheet 2 - Volume Adjustments	
Worksheet 3 - Site Characteristics	
Worksheet 4 - Critical Gap and Follow-Up Time	
Worksheet 5 - Effect of Upstream Signals	
Worksheet 6 - Impedance and Capacity Calculation	
Worksheet 7 - Effect of Two-Stage Gap Acceptance	
Worksheet 8 - Shared-Lane Capacity	
Worksheet 9 - Effect of Flared Minor-Street Approaches	

Worksheet 10 - Control Delay, Queue Length, Level of Service
 Worksheet 11 - Delay to Rank 1 Vehicles
 Part B - AWSC Unsignalized Intersections
 Worksheet 1 - Geometrics and Movements
 Worksheet 2 - Volume Adjustments and Lane Assignments
 Worksheet 3 - Saturation Headways
 Worksheet 4 - Departure Headway and Service Time
 Worksheet 5 - Capacity and Level of Service
 Part C - Roundabouts
 Roundabout Worksheet

EXHIBITS

Exhibit 17-1. TWSC Unsignalized Intersection Methodology 17-2
 Exhibit 17-2. Level-of-Service Criteria for TWSC Intersections 17-2
 Exhibit 17-3. Traffic Streams at a TWSC Intersection 17-4
 Exhibit 17-4. Definition and Computation of Conflicting Flows 17-6
 Exhibit 17-5. Base Critical Gaps and Follow-Up Times for TWSC Intersections 17-7
 Exhibit 17-6. Potential Capacity for Two-Lane Streets 17-8
 Exhibit 17-7. Potential Capacity for Four-Lane Streets 17-9
 Exhibit 17-8. Adjustment to Impedance Factors for Major Left Turn,
 Minor Through 17-11
 Exhibit 17-9. Relative Pedestrian/Vehicle Hierarchy 17-12
 Exhibit 17-10. Platoon Dispersion from Upstream Signalized Intersections 17-14
 Exhibit 17-11. Upstream Signalized Intersection 17-15
 Exhibit 17-12. Platoon Dispersion Model 17-16
 Exhibit 17-13. Platoon Dispersion Factor 17-16
 Exhibit 17-14. Platoon Overlap Cases 17-18
 Exhibit 17-15. Proportion of Analysis Period for Each Flow Regime
 (Average Case) 17-18
 Exhibit 17-16. Proportion of Analysis Period Unblocked for Each Minor
 Movement (Average Case) 17-18
 Exhibit 17-17. Two-Stage Gap Acceptance Intersection 17-20
 Exhibit 17-18. Capacity of Flared Approaches 17-21
 Exhibit 17-19. 95th-Percentile Queue Length 17-23
 Exhibit 17-20. Control Delay and Flow Rate 17-24
 Exhibit 17-21. TWSC Intersection Methodology 17-29
 Exhibit 17-22. Level-of-Service Criteria for AWSC Intersections 17-32
 Exhibit 17-23. Operation Patterns at AWSC Intersections 17-33
 Exhibit 17-24. AWSC Configuration - Formulation 1 17-34
 Exhibit 17-25. AWSC Configuration - Formulation 2 17-35
 Exhibit 17-26. Probability of Degree-of-Conflict Case 17-36
 Exhibit 17-27. Degree-of-Conflict Cases for Two-Lane Approach Intersections 17-37
 Exhibit 17-28. Degree-of-Conflict Cases for Three-Lane Approach Intersections 17-37
 Exhibit 17-29. Probability of Degree-of-Conflict Case—Multilane AWSC
 Intersections (Two-Lane Approach) 17-38
 Exhibit 17-30. Probability of Degree-of-Conflict Case—Multilane AWSC
 Intersections (Two-Lane Approaches, by Lane) 17-39
 Exhibit 17-31. AWSC Intersection Methodology 17-41
 Exhibit 17-32. Geometry Groups 17-42
 Exhibit 17-33. Saturation Headway Adjustments by Geometry Group 17-42
 Exhibit 17-34. Probability of a_j 17-43
 Exhibit 17-35. Saturation Headway Values by Case and Geometry Group 17-44

Exhibit 17-36. Analysis on One Roundabout Leg	17-46
Exhibit 17-37. Critical Gap and Follow-Up Times for Roundabouts.....	17-46
Exhibit 17-38. Roundabout Approach Capacity	17-47
Exhibit 17-39. Flow Stream Definitions	17-47

PREFACE

OVERVIEW

The procedures in this chapter can be used to analyze the capacity and level of service, lane requirements, and effects of traffic and design features of two-way stop-controlled (TWSC) and all-way stop-controlled (AWSC) intersections. In addition, a procedure for estimating capacity of roundabouts is presented.

Each type of unsignalized intersection (TWSC, AWSC, and roundabout) is addressed in a separate part of this chapter. TWSC intersections are covered in Part A, AWSC intersections are covered in Part B, and information on roundabouts is provided in Part C. References for all parts are found in Part D. Example problems that demonstrate the calculations and results achieved by applying the procedures are also found in Part D.

LIMITATIONS OF THE METHODOLOGY

This chapter does not include a detailed method for estimating delay for yield sign-controlled intersections. However, with appropriate changes in the values of key parameters, the analyst could apply the TWSC method to yield-controlled intersections.

All of the methods are for steady-state conditions (i.e., the demand and capacity conditions are constant during the analysis period); the methods are not designed to evaluate how fast or how often the facility transitions from one demand/capacity state to another. Analysts interested in that kind of information should consider applying simulation models.

PART A. TWO-WAY STOP-CONTROLLED INTERSECTIONS

I. INTRODUCTION - PART A

In this section a methodology for analyzing capacity and level of service of two-way stop-controlled (TWSC) intersections is presented.

II. METHODOLOGY - PART A

Capacity analysis at TWSC intersections depends on a clear description and understanding of the interaction of drivers on the minor or stop-controlled approach with drivers on the major street. Both gap acceptance and empirical models have been developed to describe this interaction. Procedures described in this chapter rely on a gap acceptance model developed and refined in Germany (1). The concepts from this model are described in Chapter 10. Exhibit 17-1 illustrates input to and the basic computation order of the method described in this chapter.

LEVEL-OF-SERVICE CRITERIA

Level of service (LOS) for a TWSC intersection is determined by the computed or measured control delay and is defined for each minor movement. LOS is not defined for the intersection as a whole. LOS criteria are given in Exhibit 17-2.

Background and concepts for TWSC intersections are in Chapter 10

Both theoretical and empirical approaches have been used to arrive at a methodology

LOS is not defined for the overall intersection

EXHIBIT 17-1. TWSC UNSIGNALIZED INTERSECTION METHODOLOGY

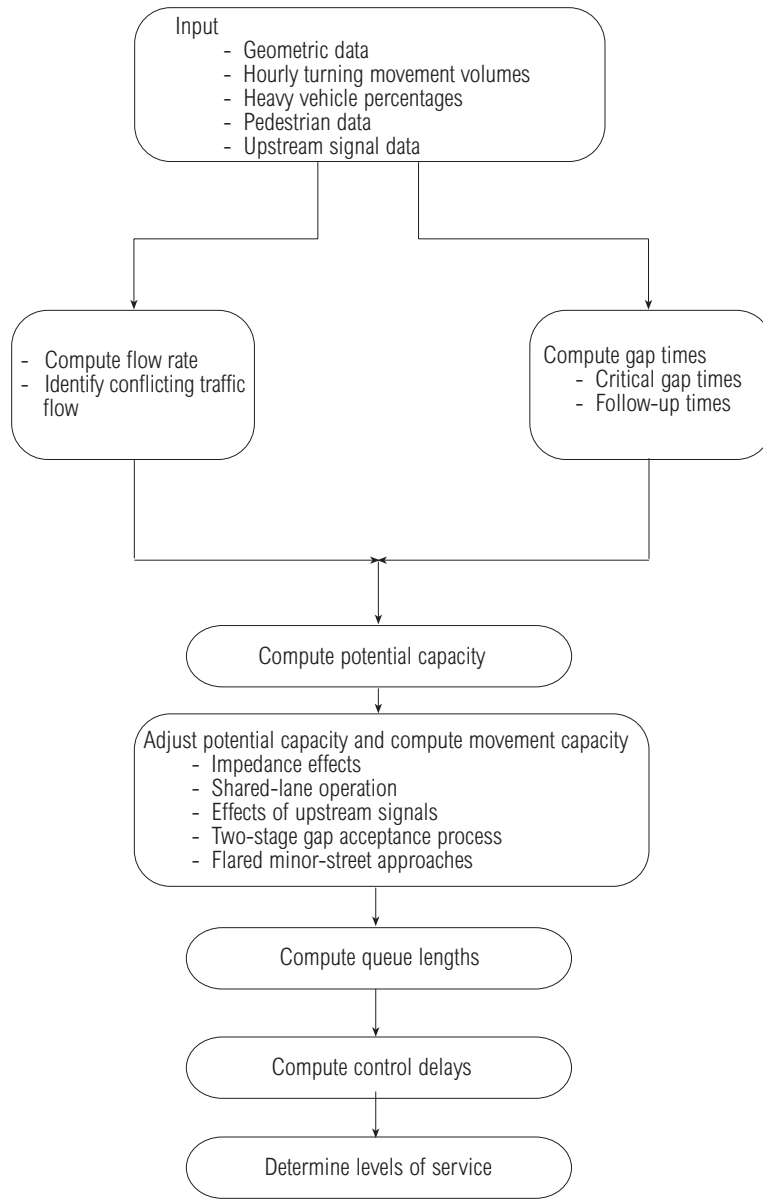

EXHIBIT 17-2. LEVEL-OF-SERVICE CRITERIA FOR TWSC INTERSECTIONS

Level of Service	Average Control Delay (s/veh)
A	0–10
B	> 10–15
C	> 15–25
D	> 25–35
E	> 35–50
F	> 50

The LOS criteria for TWSC intersections are somewhat different from the criteria used in Chapter 16 for signalized intersections primarily because different transportation facilities create different driver perceptions. The expectation is that a signalized intersection is designed to carry higher traffic volumes and experience greater delay than an unsignalized intersection.

LOS thresholds differ from those for signalized intersections to reflect different driver expectations

INPUT DATA REQUIREMENTS

Data requirements for the TWSC intersection methodology are similar to those for other capacity analysis techniques. Detailed descriptions of the geometrics, control, and volumes at the intersection are needed.

Key geometric factors include number and use of lanes, channelization, two-way left-turn lane (TWLTL) or raised or striped median storage (or both), approach grade, and existence of flared approaches on the minor street.

The number and use of lanes are critical factors. Vehicles in adjacent lanes can use the same gap in the traffic stream simultaneously (unless impeded by a conflicting user of the gap). When movements share lanes, only one vehicle from those movements can use each gap. A TWLTL or a raised or striped median (or both) allows a minor-stream vehicle to cross one major traffic stream at a time. The grade of the approach has a direct and measurable effect on the capacity of each minor movement. Compared with a level approach, downgrades increase capacity and upgrades decrease capacity. A flared approach on the minor street increases the capacity by allowing more vehicles to be served simultaneously.

Volumes must be specified by movement. For the analysis to reflect conditions during the peak 15 min, the analyst must divide the full hour volumes by the peak-hour factor (PHF) before beginning computations. If the analyst has peak 15-min flow rates, they can be entered directly with the PHF set to 1.0. The adjusted flow rate for movement x is designated as v_x in this chapter.

By convention, subscripts 1 to 6 define vehicle movements on the major street, and subscripts 7 to 12 define movements on the minor street. Pedestrian flows impede all minor-street movements. Pedestrian volumes must be specified by movement. Subscripts 13 to 16 define the pedestrian movements.

The presence of traffic signals upstream from the intersection on the major street will produce nonrandom flows and affect the capacity of the minor-street approaches if the signal is within 0.25 mi of the intersection. The basic capacity model assumes that the headways on the major street are exponentially distributed. To assess the effect on capacity, a separate analysis is provided that requires the signalized intersection data (cycle length, green time), the saturation flow rate, and information on platooned flow.

PRIORITY OF STREAMS

In using the methodology, the priority of right-of-way given to each traffic stream must be identified. Some streams have absolute priority, whereas others have to give way or yield to higher-order streams. Exhibit 17-3 shows the relative priority of streams at both T- and four-leg intersections.

Movements of Rank 1 (denoted by the subscript i) include through traffic on the major street and right-turning traffic from the major street. Movements of Rank 2 (subordinate to 1 and denoted by the subscript j) include left-turning traffic from the major street and right-turning traffic onto the major street.

Movements of Rank 3 (subordinate to 1 and 2 and denoted by the subscript k) include through traffic on the minor street (in the case of a four-leg intersection) and left-turning traffic from the minor street (in the case of a T-intersection). Movements of Rank 4 (subordinate to all others and denoted by the subscript l) include left-turning traffic from the minor street. Rank 4 movements only occur at four-leg intersections.

Rank	Subscript
1	i
2	j
3	k
4	l

EXHIBIT 17-3. TRAFFIC STREAMS AT A TWSC INTERSECTION

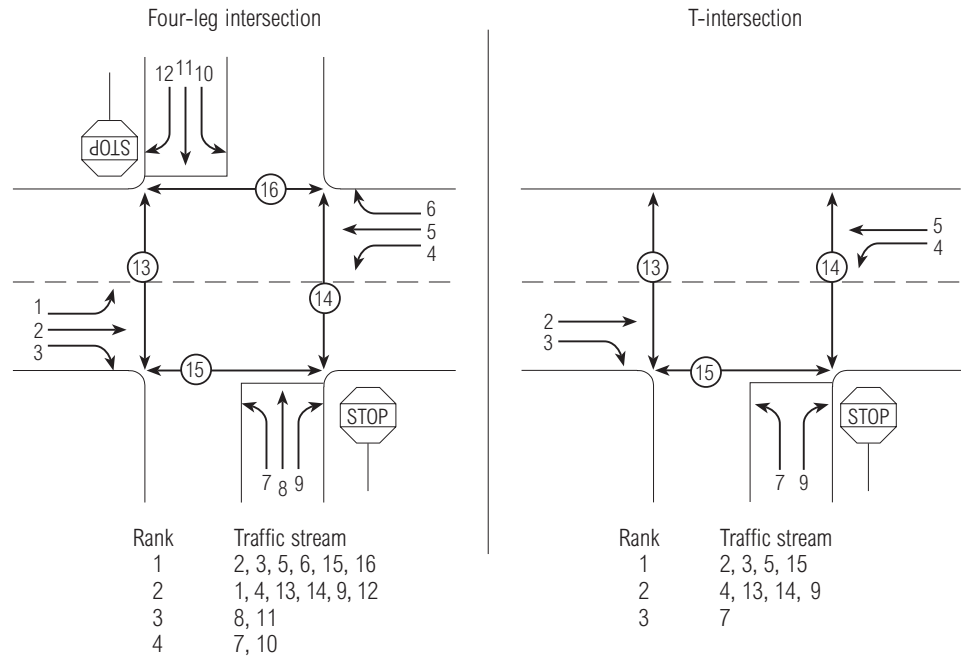

Pedestrians are treated as movements

For example, if a left-turning vehicle on the major street and a through vehicle from the minor street are waiting to cross the major traffic stream, the first available gap of acceptable size would be taken by the left-turning vehicle. The minor-street through vehicle must wait for the second available gap. In aggregate terms, a large number of such left-turning vehicles could use up so many of the available gaps that minor-street through vehicles would be severely impeded or unable to make safe crossing movements.

Because right-turning vehicles from the minor street merely merge into gaps in the right-hand lane of the stream into which they turn, they require only a gap in that lane, not in the entire major-street traffic flow (this may not be true for some trucks and vans with long wheelbases that encroach on more than one lane in making their turn). Furthermore, a gap in the overall major-street traffic could be used simultaneously by another vehicle. For this reason, the method assumes that right turns from the minor street do not impede any of the other flows using major-street gaps.

Pedestrian movements also have priorities with respect to vehicular movements. While this may be a policy issue varying by jurisdiction, both the American Association of State Highway and Transportation Officials (AASHTO) (2) and the *Manual on Uniform Traffic Control Devices* (MUTCD) (3) infer that pedestrians must use acceptable gaps in major-street (Rank 1) traffic streams and that pedestrians have priority over all minor-street traffic at a TWSC intersection. Specific rankings are shown in Exhibit 17-3.

CONFLICTING TRAFFIC

Each movement at a TWSC intersection faces a different set of conflicts that are directly related to the nature of the movement. These conflicts are shown in Exhibit 17-4, which illustrates the computation of the parameter $v_{c,x}$, the conflicting flow rate for movement x, that is, the total flow rate that conflicts with movement x (veh/h).

The right-turn movement from the minor street, for example, is in conflict with only the major-street through movement in the right-hand lane into which right-turners will merge. Exhibit 17-4 includes one-half of the right-turn movement from the major street, because only some of these turns tend to inhibit the subject movement.

Left turns from the major street are in conflict with the total opposing through and right-turn flows, because they must cross the through flow and merge with the right-turn flow. The method does not differentiate between crossing and merging conflicts. Left turns from the major street and the opposing right turns from the major street are considered to merge, regardless of the number of lanes provided in the exit roadway.

Minor-street through movements have a direct crossing or merging conflict with all movements on the major street, as indicated in Exhibit 17-4, except the right turn into the subject approach. Only one-half of this movement is included in the computation, for the reasons discussed above. In addition, field research (4) has shown that the effect of left-turn vehicles is twice their actual number. This effect is reflected in Exhibit 17-4.

The left turn from the minor street is the most difficult maneuver to execute at a TWSC intersection, and it faces the most complex set of conflicting flows, which include all major-street flows, in addition to the opposing right-turn and through movements on the minor street. Only one-half of the opposing right-turn and through movement flow rate is included as conflicting flow rate because both movements are stop-controlled and their effect on left turns is diminished. The additional capacity impedance effects of the opposing right-turn and through movement flow rates are taken into account elsewhere in the procedure.

Pedestrians may also conflict with vehicular traffic streams. Pedestrian flow rates, also defined as v_x , with x noting the leg of the intersection being crossed, should be included as part of the conflicting flow rates, since they, like vehicular flows, define the beginning or ending of a gap that may be used by a minor-stream vehicle. Although it recognizes some peculiarities associated with pedestrian flows, this method takes a uniform approach to vehicular and pedestrian movements.

While regulations or practices may vary between jurisdictions, this methodology assumes that pedestrians crossing the subject or opposing approaches have Rank 1 status and that pedestrians crossing the two conflicting approaches to the left or right of the subject minor-street approach have Rank 2 status. The conflicting pedestrian flow rates are identified in Exhibit 17-4.

Exhibit 17-4 also identifies the conflicting flow rates for each stage of a two-stage gap acceptance process that takes place at some intersections where vehicles store in the median area. If a two-stage gap acceptance process is not present, the conflicting flow rates shown in the rows labeled Stage I and Stage II should be added together and considered as one conflicting flow rate for the movement in question.

CRITICAL GAP AND FOLLOW-UP TIME

The critical gap, t_c , is defined as the minimum time interval in the major-street traffic stream that allows intersection entry for one minor-street vehicle (5). Thus, the driver's critical gap is the minimum gap that would be acceptable. A particular driver would reject any gaps less than the critical gap and would accept gaps greater than or equal to the critical gap. Estimates of critical gap can be made on the basis of observations of the largest rejected and smallest accepted gap for a given intersection.

The time between the departure of one vehicle from the minor street and the departure of the next vehicle using the same major-street gap, under a condition of continuous queuing on the minor street, is called the follow-up time, t_f . Thus, t_f is the headway that defines the saturation flow rate for the approach if there were no conflicting vehicles on movements of higher rank.

In using Exhibit 17-4 to compute conflicting flow rates, the analyst should carefully consult the footnotes, which allow modifications to the equations in special cases.

Critical gap defined

Follow-up time defined

EXHIBIT 17-4. DEFINITION AND COMPUTATION OF CONFLICTING FLOWS

The following footnotes apply to Exhibit 17-4:

[a] If right-turning traffic from the major street is separated by a triangular island and has to comply with a yield or stop sign, v_6 and v_3 need not be considered.

[b] If there is more than one lane on the major street, the flow rates in the right lane are assumed to be v_2/N or v_3/N , where N is the number of through lanes. The user can specify a different lane distribution if field data are available.

[c] If there is a right-turn lane on the major street, v_3 or v_6 should not be considered.

[d] Omit the farthest right-turn v_3 for Subject Movement 10 or v_6 for Subject Movement 7 if the major street is multilane.

[e] If right-turning traffic from the minor street is separated by a triangular island and has to comply with a yield or stop sign, v_9 and v_{12} need not be considered.

[f] Omit v_9 and v_{12} for multilane sites, or use one-half their values if the minor approach is flared.

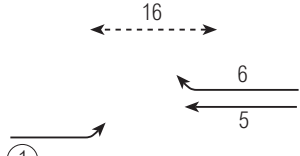
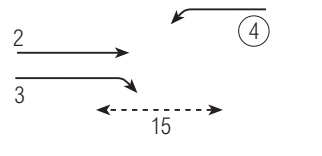
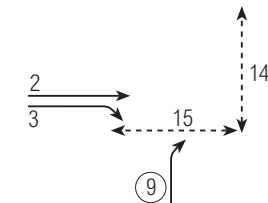
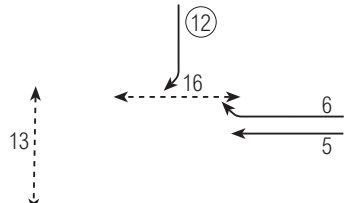
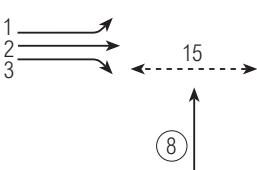
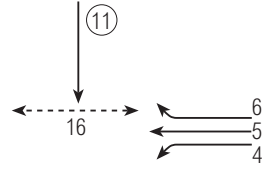
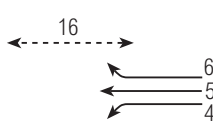
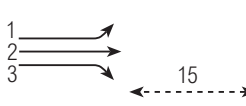
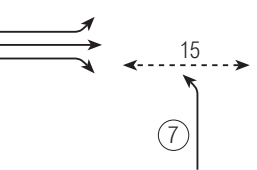
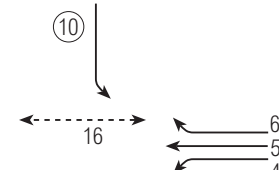
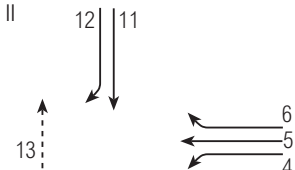
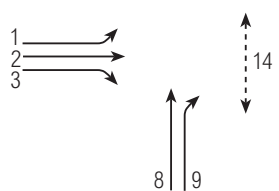
Subject Movement	Subject and Conflicting Movements Conflicting Traffic Flows, $v_{c,x}$	
Major LT (1, 4)	 $v_{c,1} = v_5 + v_6^{[a]} + v_{16}$	 $v_{c,4} = v_2 + v_3^{[a]} + v_{15}$
Minor RT (9, 12)	 $v_{c,9} = \frac{v_2^{[b]}}{N} + 0.5v_3^{[c]} + v_{14} + v_{15}$	 $v_{c,12} = \frac{v_5^{[b]}}{N} + 0.5v_6^{[c]} + v_{13} + v_{16}$
Minor TH (8, 11)	<p>Stage I</p>  $v_{c,I,8} = 2v_1 + v_2 + 0.5v_3^{[c]} + v_{15}$	 $v_{c,I,11} = 2v_4 + v_5 + 0.5v_6^{[c]} + v_{16}$
	<p>Stage II</p>  $v_{c,II,8} = 2v_4 + v_5 + v_6^{[a]} + v_{16}$	 $v_{c,II,11} = 2v_1 + v_2 + v_3^{[a]} + v_{15}$
Minor LT (7, 10)	<p>Stage I</p>  $v_{c,I,7} = 2v_1 + v_2 + 0.5v_3^{[c]} + v_{15}$	 $v_{c,I,10} = 2v_4 + v_5 + 0.5v_6^{[c]} + v_{16}$
	<p>Stage II</p>  $v_{c,II,7} = 2v_4 + \frac{v_5}{N} + 0.5v_6^{[d]} + 0.5v_{12}^{[e,f]} + 0.5v_{11} + v_{13}$	 $v_{c,II,10} = 2v_1 + \frac{v_2}{N} + 0.5v_3^{[d]} + 0.5v_9^{[e,f]} + 0.5v_8 + v_{14}$

Base values of t_c and t_f for passenger cars are given in Exhibit 17-5. The values are based on studies throughout the United States and are representative of a broad range of conditions. Base values of t_c and t_f for a six-lane major street are assumed to be the same as those for a four-lane major street. Adjustments are made to account for the presence of heavy vehicles, approach grade, T-intersections, and two-stage gap acceptance. The critical gap is computed separately for each minor movement by Equation 17-1.

$$t_{c,x} = t_{c,base} + t_{c,HV} P_{HV} + t_{c,G} G - t_{c,T} - t_{3,LT} \quad (17-1)$$

where

- $t_{c,x}$ = critical gap for movement x (s),
- $t_{c,base}$ = base critical gap from Exhibit 17-5 (s),
- $t_{c,HV}$ = adjustment factor for heavy vehicles (1.0 for two-lane major streets and 2.0 for four-lane major streets) (s),
- P_{HV} = proportion of heavy vehicles for minor movement,
- $t_{c,G}$ = adjustment factor for grade (0.1 for Movements 9 and 12 and 0.2 for Movements 7, 8, 10, and 11) (s),
- G = percent grade divided by 100,
- $t_{c,T}$ = adjustment factor for each part of a two-stage gap acceptance process (1.0 for first or second stage; 0.0 if only one stage) (s), and
- $t_{3,LT}$ = adjustment factor for intersection geometry (0.7 for minor-street left-turn movement at three-leg intersection; 0.0 otherwise) (s).

$t_{c,T}$ is applicable to Movements 7, 8, 10, and 11

EXHIBIT 17-5. BASE CRITICAL GAPS AND FOLLOW-UP TIMES FOR TWSC INTERSECTIONS

Vehicle Movement	Base Critical Gap, $t_{c,base}$ (s)		Base Follow-up Time, $t_{f,base}$ (s)
	Two-Lane Major Street	Four-Lane Major Street	
Left turn from major	4.1	4.1	2.2
Right turn from minor	6.2	6.9	3.3
Through traffic on minor	6.5	6.5	4.0
Left turn from minor	7.1	7.5	3.5

Base factors for a six-lane major street are assumed to be the same as those for a four-lane major street

The follow-up time is computed for each minor movement using Equation 17-2. Adjustments are made for the presence of heavy vehicles.

$$t_{f,x} = t_{f,base} + t_{f,HV} P_{HV} \quad (17-2)$$

where

- $t_{f,x}$ = follow-up time for minor movement x (s),
- $t_{f,base}$ = base follow-up time from Exhibit 17-5 (s),
- $t_{f,HV}$ = adjustment factor for heavy vehicles (0.9 for two-lane major streets and 1.0 for four-lane major streets), and
- P_{HV} = proportion of heavy vehicles for minor movement.

Values from Exhibit 17-5 are considered typical. If smaller values for t_c and t_f are observed, capacity will be increased. If larger values for t_c and t_f are used, capacity will be decreased. More accurate capacity estimates will be produced if field measurements of the critical gap and follow-up time can be made.

It should be noted that the critical gap data for multilane sites account for the actual lane distribution of traffic flows measured at each site. This accounts for the higher value of critical gap for the minor-street right turn (6.9 s) compared with the value for the minor through movement (6.5 s).

POTENTIAL CAPACITY

The gap acceptance model used in this method computes the potential capacity of each minor traffic stream in accordance with Equation 17-3 (6, 7).

Equation 17-3 is also used for major-street left-turn movements

$$C_{p,x} = V_{c,x} \frac{e^{-V_{c,x}t_{c,x}/3600}}{1 - e^{-V_{c,x}t_{f,x}/3600}} \tag{17-3}$$

where

- $C_{p,x}$ = potential capacity of minor movement x (veh/h),
- $V_{c,x}$ = conflicting flow rate for movement x (veh/h),
- $t_{c,x}$ = critical gap (i.e., the minimum time that allows intersection entry for one minor-stream vehicle) for minor movement x (s), and
- $t_{f,x}$ = follow-up time (i.e., the time between the departure of one vehicle from the minor street and the departure of the next under a continuous queue condition) for minor movement x (s).

The potential capacity of a movement is denoted as $c_{p,x}$ (for movement x) and is defined as the capacity for a specific movement, assuming the following base conditions:

- Traffic from nearby intersections does not back up into the subject intersection.
- A separate lane is provided for the exclusive use of each minor-street movement.
- An upstream signal does not affect the arrival pattern of the major-street traffic.
- No other movements of Rank 2, 3, or 4 impede the subject movement.

MOVEMENT CAPACITY

The potential capacity, $c_{p,x}$, of minor-street movements is given in Exhibit 17-6 for a two-lane major street and in Exhibit 17-7 for a four-lane major street. These figures show the application of Equation 17-3 with the values presented in Exhibit 17-5. The potential capacity is expressed as vehicles per hour (veh/h). The exhibits indicate that the potential capacity is a function of the conflicting flow rate $v_{c,x}$ expressed as an hourly rate, as well as the minor-street movement.

Potential capacity defined

EXHIBIT 17-6. POTENTIAL CAPACITY FOR TWO-LANE STREETS

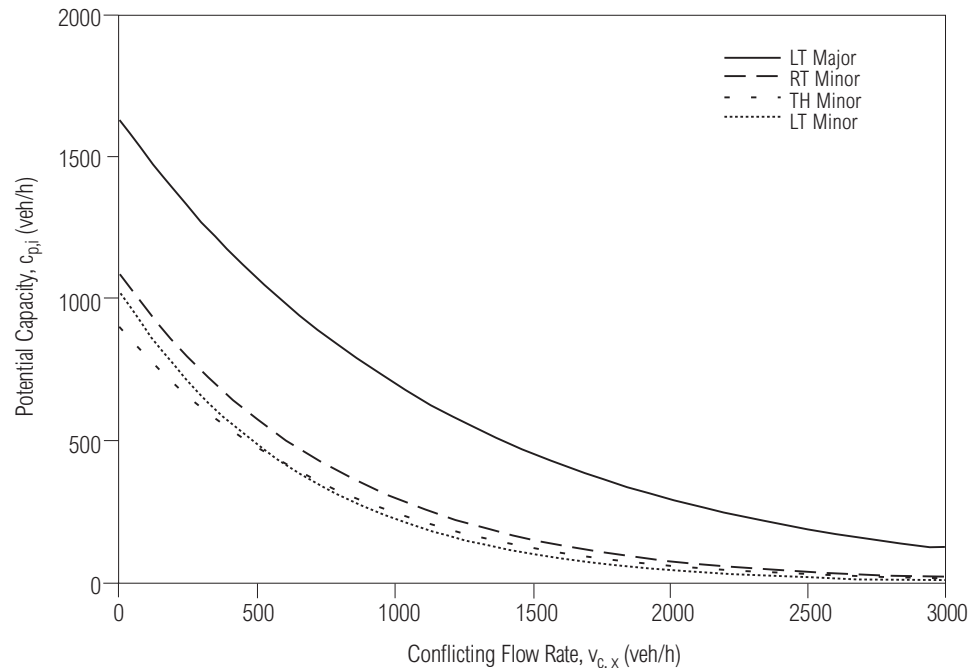
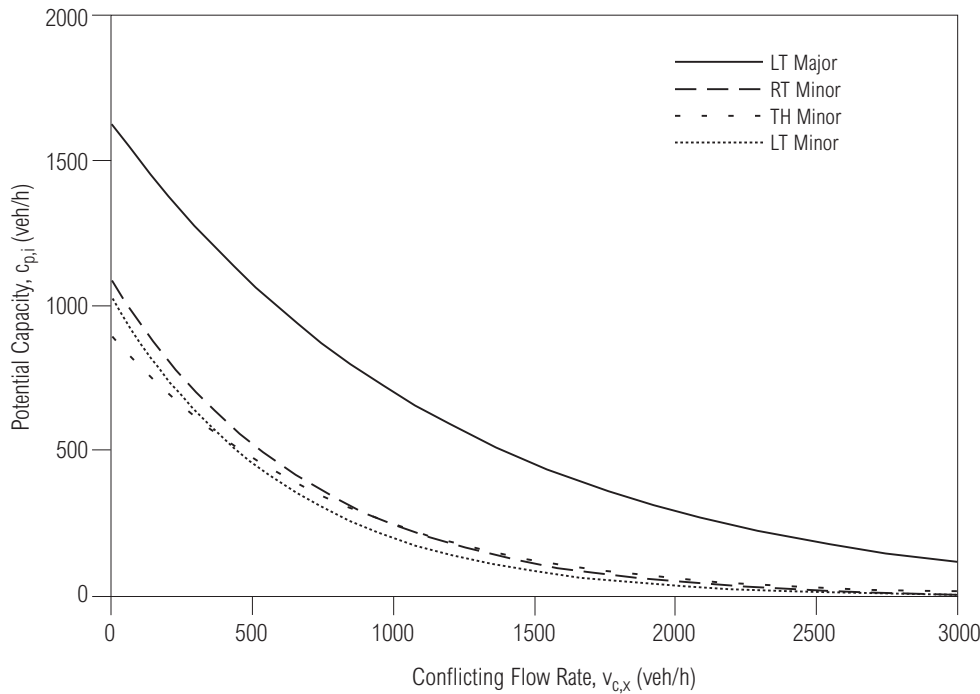

EXHIBIT 17-7. POTENTIAL CAPACITY FOR FOUR-LANE STREETS



Impedance Effects

Vehicle Impedance

Vehicles use gaps at a TWSC intersection in a prioritized manner. When traffic becomes congested in a high-priority movement, it can impede lower-priority movements (i.e., streams of Ranks 3 and 4) from using gaps in the traffic stream, reducing the potential capacity of these movements.

Major traffic streams of Rank 1 are assumed to be unimpeded by any of the minor traffic stream movements. This rank also implies that major traffic streams are not expected to incur delay or slowing as they travel through the TWSC intersection. Empirical observations have shown that such delays do occasionally occur, and they are accounted for by using adjustments provided in the procedures.

Minor traffic streams of Rank 2 (including left turns from the major street and right turns from the minor street) must yield only to the major-street through and right-turning traffic streams of Rank 1. There are no additional impedances from other minor traffic streams, and so the movement capacity of each Rank 2 traffic stream is equal to its potential capacity as indicated by Equation 17-4.

$$c_{m,j} = c_{p,j} \tag{17-4}$$

where j denotes movements of Rank 2 priority.

Minor traffic streams of Rank 3 must yield not only to the major traffic streams, but also to the conflicting major-street left-turn movement, which is of Rank 2. Thus, not all gaps of acceptable length that pass through the intersection will normally be available for use by Rank 3 traffic streams, because some of these gaps are likely to be used by the major-street left-turning traffic. The magnitude of this impedance depends on the probability that major-street left-turning vehicles will be waiting for an acceptable gap at the same time as vehicles of Rank 3. A higher probability that this situation will occur means greater capacity-reducing effects of the major-street left-turning traffic on all Rank 3 movements.

Compute $c_{p,j}$ using Equation 17-3

If major-street through and left-turn movements are shared, use Equation 17-16. Also use Equation 17-5 to compute the probability of queue-free state for Rank 3 movements.

Also account for pedestrian impedance, if significant

What is of interest to the analyst, therefore, is the probability that the major-street left-turning traffic will operate in a queue-free state. This probability is expressed by Equation 17-5:

$$p_{0,j} = 1 - \frac{v_j}{c_{m,j}} \tag{17-5}$$

where $j = 1, 4$ (major-street left-turn movements of Rank 2).

The movement capacity, $c_{m,k}$, for all Rank 3 movements is found by calculating a capacity adjustment factor that accounts for the impeding effects of higher-ranked movements. The capacity adjustment factor is denoted by f_k for all movements k and for all Rank 3 movements and is given by Equation 17-6.

$$f_k = \prod_j p_{0,j} \tag{17-6}$$

where

- $p_{0,j}$ = probability that conflicting Rank 2 movement j will operate in a queue-free state, and
- k = Rank 3 movements.

The movement capacity for the Rank 3 movements is computed using Equation 17-7.

$$c_{m,k} = (c_{p,k})f_k \tag{17-7}$$

Rank 4 movements (i.e., only the minor-street left turns at a four-leg intersection) can be impeded by the queues of three higher-ranked traffic streams:

- Major-street left-turning movements (Rank 2),
- Minor-street crossing movements (Rank 3), and
- Minor-street right-turning movements (Rank 2).

If the intersection has three legs, then the minor-street left turn is a Rank 3 movement and should be evaluated using Equations 17-5 through 17-7.

The probability that each of these higher-ranked traffic streams will operate in a queue-free state is central to determining their overall impeding effects on the minor-street left-turn movement. At the same time, it must be recognized that not all of these probabilities are independent of each other. Specifically, queuing in the major-street left-turning movement affects the probability of a queue-free state in the minor-street crossing movement. Applying the simple product of these two probabilities will likely overestimate the impeding effects on the minor-street left-turning traffic.

Exhibit 17-8 can be used to adjust for the overestimate caused by the statistical dependence between queues in streams of Ranks 2 and 3. The mathematical representation of this curve is given by Equation 17-8.

$$p' = 0.65p'' - \frac{p''}{p'' + 3} + 0.6\sqrt{p''} \tag{17-8}$$

where

- p' = adjustment to the major-street left, minor-street through impedance factor;
- p'' = $(p_{0,j})(p_{0,k})$;
- $p_{0,j}$ = probability of a queue-free state for the conflicting major-street left-turning traffic; and
- $p_{0,k}$ = probability of a queue-free state for the conflicting minor-street crossing traffic.

EXHIBIT 17-8. ADJUSTMENT TO IMPEDANCE FACTORS FOR MAJOR LEFT TURN, MINOR THROUGH

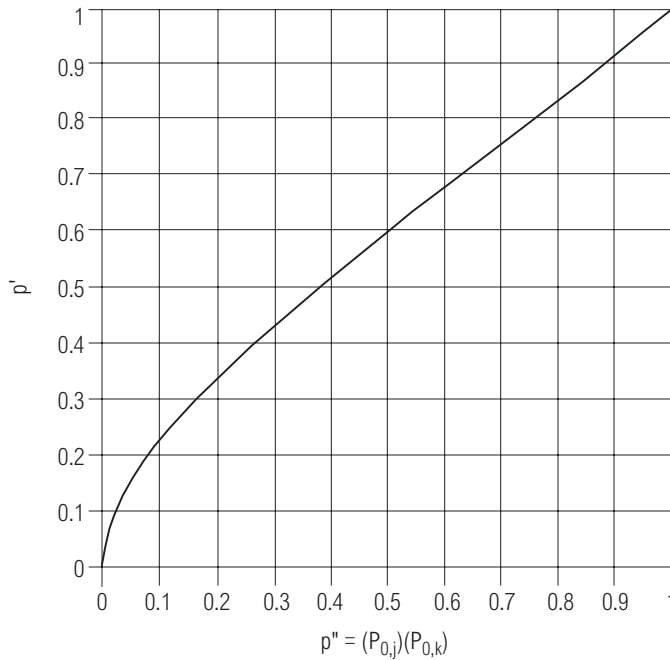

The capacity adjustment factor for the Rank 4 minor-street left-turn movements can be computed by Equation 17-9:

$$f_l = (p')(p_{0,j}) \tag{17-9}$$

where

- l* = minor-street left-turn movement of Rank 4 (Movements 7 and 10 in Exhibit 17-3), and
- j* = conflicting Rank 2 minor-street right-turn movement (Movements 9 and 12 in Exhibit 17-3).

The variable $p_{0,j}$ should be included in Equation 17-9 only if movement *j* is identified as a conflicting movement. Refer to Exhibit 17-4 and the associated notes.

Finally, the movement capacity for the minor-street left-turn movements of Rank 4 can be determined from Equation 17-10:

$$c_{m,l} = (f_l)(c_{p,l}) \tag{17-10}$$

where *l* indicates movements of Rank 4 priority.

Rank 4 movements occur only at four-leg intersections. Equations 17-8 to 17-10 are only required when evaluating four-leg intersections.

Pedestrian Impedance

Minor-street vehicle streams must yield to pedestrian streams. Exhibit 17-9 shows the relative hierarchy between pedestrian and vehicular streams used in this methodology. A factor accounting for pedestrian blockage is computed by Equation 17-11 on the basis of pedestrian volume, the pedestrian walking speed, and the lane width.

$$f_{pb} = \frac{(v_x) \left(\frac{w}{S_p} \right)}{3600} \tag{17-11}$$

Compute $c_{p,l}$ using Equation 17-3

where

- f_{pb} = pedestrian blockage factor, or the proportion of time that one lane on an approach is blocked during 1 h;
- v_x = number of groups of pedestrians, where x is Movement 13, 14, 15, or 16, as described in Equation 18-18;
- w = lane width (ft); and
- S_p = pedestrian walking speed, assumed to be 4.0 ft/s.

EXHIBIT 17-9. RELATIVE PEDESTRIAN/VEHICLE HIERARCHY

Vehicle Stream	Must Yield to Pedestrian Stream	Impedance Factor for Pedestrians, $p_{p,x}$
v_1	v_{16}	$p_{p,16}$
v_4	v_{15}	$p_{p,15}$
v_7	v_{15}, v_{13}	$(p_{p,15}) (p_{p,13})$
v_8	v_{15}, v_{16}	$(p_{p,15}) (p_{p,16})$
v_9	v_{15}, v_{14}	$(p_{p,15}) (p_{p,14})$
v_{10}	v_{16}, v_{14}	$(p_{p,16}) (p_{p,14})$
v_{11}	v_{15}, v_{16}	$(p_{p,15}) (p_{p,16})$
v_{12}	v_{16}, v_{13}	$(p_{p,16}) (p_{p,13})$

The pedestrian impedance factor for pedestrian movement x, $p_{p,x}$, is computed by Equation 17-12.

$$p_{p,x} = 1 - f_{pb} \tag{17-12}$$

If pedestrians are present to a significant degree, $p_{p,x}$ is included as a factor in Equations 17-6 and 17-9. Equation 17-6 becomes

$$f_k = \prod_j (p_{o,j}) p_{p,x} \tag{17-13}$$

where $p_{p,x}$ takes on the values shown in Exhibit 17-9.

Equation 17-9 becomes

$$f_l = p' p_{o,j} p_{p,x} \tag{17-14}$$

where $p_{p,x}$ takes on the value $p_{p,13}$ $p_{p,15}$ for Stream 7 and $p_{p,14}$ $p_{p,16}$ for Stream 10. Refer to Chapter 18 for a methodology to determine performance measures from a pedestrian perspective at unsignalized intersections.

Shared-Lane Capacity

Minor-Street Approaches

Where several movements share the same lane and cannot stop side-by-side at the stop line, Equation 17-15 is used to compute shared-lane capacity.

$$c_{SH} = \frac{\sum_y v_y}{\sum_y \left(\frac{v_y}{c_{m,y}} \right)} \tag{17-15}$$

where

- c_{SH} = capacity of the shared lane (veh/h),
- v_y = flow rate of the y movement in the subject shared lane (veh/h), and
- $c_{m,y}$ = movement capacity of the y movement in the subject shared lane (veh/h).

Major-Street Approaches

The methodology implicitly assumes that an exclusive lane is provided to all left-turning traffic from the major street. In situations where a left-turn lane is not provided, major-street through (and possibly right-turning) traffic could be delayed by left-turning vehicles waiting for an acceptable gap. To account for this possibility, the factors $p_{0,1}^*$ and $p_{0,4}^*$ may be computed as an indication of the probability that there will be no queue in the respective major-street shared lanes.

$$p_{0,j}^* = 1 - \frac{1 - p_{0,j}}{1 - \left(\frac{v_{i1}}{s_{i1}} + \frac{v_{i2}}{s_{i2}} \right)} \quad (17-16)$$

where

- $p_{0,j}$ = probability of queue-free state for movement j assuming an exclusive left-turn lane on the major street,
- j = 1, 4 (major-street left-turning traffic streams),
- $i1$ = 2, 5 (major-street through traffic streams),
- $i2$ = 3, 6 (major-street right-turning traffic streams),
- s_{i1} = saturation flow rate for the major-street through traffic streams (veh/h) (this parameter can be measured in the field),
- s_{i2} = saturation flow rate for the major-street right-turning traffic (veh/h) (this parameter can be measured in the field),
- v_{i1} = major-street through flow rate (veh/h), and
- v_{i2} = major-street right-turning flow rate (or 0 if an exclusive right-turn lane is provided) (veh/h).

When $j = 1$, $i1 = 21$ and $i2 = 32$; when $j = 4$, $i1 = 51$ and $i2 = 62$

By using $p_{0,1}^*$ and $p_{0,4}^*$ in lieu of $p_{0,1}$ and $p_{0,4}$ (as computed by Equation 17-5), the potential for queues on a major street with shared left-turn lanes may be taken into account.

Upstream Signals

The effects of upstream intersections can only be completely assessed with an appropriate simulation model or field data. An appropriate model would include the ability to represent traffic interactions in the gap acceptance process, platoon dispersion qualities, and signalized intersection control systems.

The method considers the flow patterns resulting from traffic signals located on the major street upstream of the subject TWSC intersection and the headway distribution resulting from the platooned flow. The method is based on a platoon dispersion algorithm (8-10). Exhibit 17-10 shows a generalized case of a TWSC intersection located on a major street between two signalized intersections. The queues that form at each signalized intersection during red phases will disperse as they travel downstream away from the signalized intersection.

Four flow regimes, and thus headway distributions, result as the platoons arrive at the unsignalized intersection:

- Regime 1: no platoons,
- Regime 2: platoon from the left only,
- Regime 3: platoon from the right only, and
- Regime 4: platoons from both directions.

EXHIBIT 17-10. PLATOON DISPERSION FROM UPSTREAM SIGNALIZED INTERSECTIONS

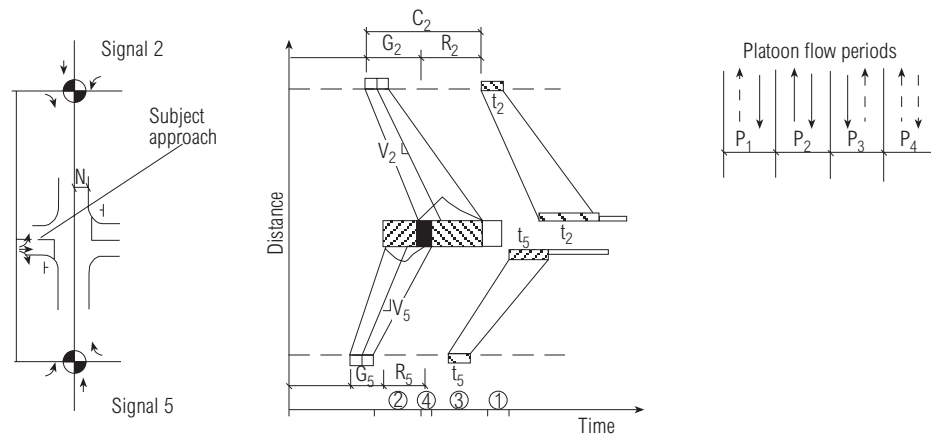

During Regime 1, minor-stream vehicles enter the subject TWSC intersection as described by the traditional gap acceptance process. Whereas platoons are present from both directions during Regime 4, no minor-stream vehicles are able to enter the subject intersection since the mean headways of the platoon are assumed to be less than the critical gap. Some of the minor-stream movements are blocked by the platoon during Regimes 2 and 3 and are unable to enter the subject intersection. A minor stream is considered to be blocked if a conflicting platoon is traveling through the TWSC intersection; the stream is considered to be unblocked if no conflicting platoons are traveling through the TWSC intersection.

If the traffic signals at the two upstream intersections are coordinated, these patterns are predictable and occur at regular intervals. On the basis of the flow pattern that exists during each regime, the capacity can be estimated. If one or both of the signals are actuated, the patterns are less predictable.

Inputs for analysis of platoons

The analyst needs the following data for each upstream signal:

- Cycle length, C (s);
- Major-street effective green time, g_{eff} (s);
- Saturation flow rate, s (veh/h);
- Distance from the signalized intersection to the TWSC intersection, D (ft);
- Speed of the platoon as it progresses from the signalized intersection to the TWSC intersection, S_{prog} (ft/s);
- Upstream flow rate, including the through flow rate from the major-street approach and, if applicable and significant, the left-turn flow rate from the minor street during an exclusive left-turn phase; and
- Arrival type of vehicles at the signalized intersection.

The method includes five sets of computations as identified in the following sections.

Time to Clear Standing Queue - Computation 1

In a typical four-leg upstream intersection, three movements combine to constitute the exit-leg flow in the direction of the subject TWSC intersection. This is shown in Exhibit 17-11.

The flow v_{out} consists of two components. One is a stable platoon discharging at the saturation flow rate when the signal changes from red to green. The second is more or less random arrivals and departures, or a platoon from another upstream signal passing through on the green phase.

In the context of this chapter, the first component includes both the portion of v_T that arrives during red and the portion that arrives during green when the standing queue is clearing. It also includes v_L for the same periods if v_L has an exclusive left-turn lane and

a protected green phase. The second component includes the portion of v_T (and v_L , if applicable) that arrives after the queue has cleared.

EXHIBIT 17-11. UPSTREAM SIGNALIZED INTERSECTION

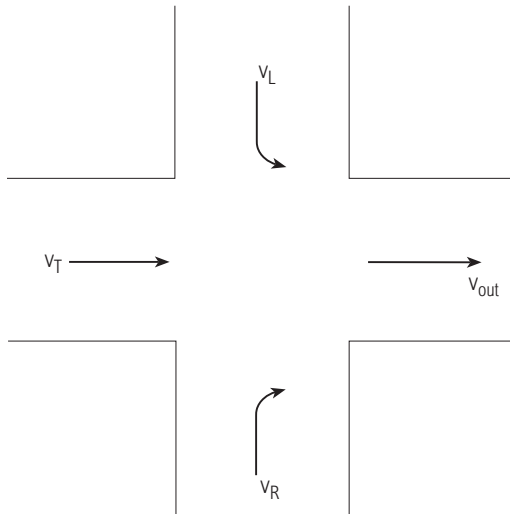

The platooning effect of v_R is not considered in this methodology

The time required for a standing queue to clear depends on the pattern of vehicles arriving at the upstream signalized intersection. The arrival pattern (designated arrival type in Chapter 16) is determined by the proportion of vehicles arriving during the green phase.

The proportion of vehicles arriving on green is computed by Equation 17-17.

$$P = R_p(g_{eff}/C), \quad P \leq 1.0 \quad (17-17)$$

where R_p is a function of the arrival type (see Chapter 16).

The time to discharge the vehicles that arrive during red is given by Equation 17-18.

$$g_{q1} = \frac{v_{prog} C(1 - P)}{s} \quad (17-18)$$

where v_{prog} is either $v_{T,prog}$ or $v_{L,prot}$ and s is the total saturation flow rate of the through or left movement of the upstream signalized intersection.

The time to discharge the vehicles that arrive on green and join the back of the queue is given by Equation 17-19.

$$g_{q2} = \frac{v_{prog} CPg_{q1}}{sg_{eff} - v_{prog} CP} \quad (17-19)$$

where v_{prog} is either $v_{T,prog}$ or $v_{L,prot}$.

The total time to discharge the queue is given by Equation 17-20.

$$g_q = g_{q1} + g_{q2} \quad (17-20)$$

where g_q is less than or equal to g_{eff} .

Proportion of Time TWSC Intersection Is Blocked - Computation 2

The discharging queue from the upstream signal will disperse as it travels downstream toward the subject TWSC intersection. A platoon dispersion model is used to determine the length of time that the TWSC intersection is blocked by the densest part of the platoon. The platoon headways are smaller than the critical gap, and thus no minor movement at the TWSC intersection can enter the intersection during the passage of the platoon. See Exhibit 17-12.

If an exclusive LT lane exists, determine

- g_{q1} for TH movement
- g_{q1} for LT movement
- g_{q2} for TH movement
- g_{q2} for LT movement

EXHIBIT 17-12. PLATOON DISPERSION MODEL

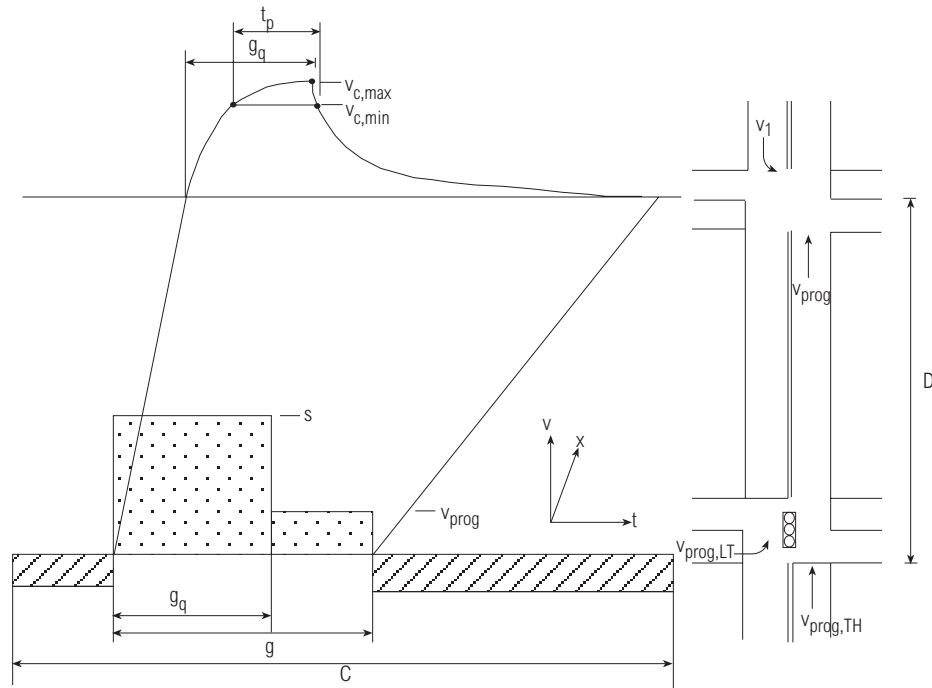

The basic platoon dispersion model parameters are listed below:

- α = platoon dispersion factor, obtained from Exhibit 17-13;
- $\beta = (1 + \alpha)^{-1}$;
- $t_a = D/S_{prog}$, the travel time from the signalized intersection to the TWSC intersection (s), where D is the distance from the upstream signal to the subject movement (m) and S_{prog} is the average platoon running speed;
- $F = (1 + \alpha\beta t_a)^{-1}$; and
- $f = v_{prog}/v_c$, the proportion of the conflicting flow that originated as the platoon at the upstream signal, where v_{prog} is either $v_{T,prog}$ when considering the platoon generated by the through movement or the protected left-turn movement ($v_{L,prot}$) when considering the platoon generated by the protected left-turn movement from the minor street, and v_c is the major-street flow rate.

EXHIBIT 17-13. PLATOON DISPERSION FACTOR

Median Type	Factor, α		
	Two TH Lanes	Four TH Lanes	Six TH Lanes
Undivided	0.55	0.50	0.40
Raised Curb	0.45	0.40	0.35
TWLTL	0.40	0.35	0.30

The maximum platooned flow rate in the conflicting stream is given by Equation 17-21.

$$v_{c,max} = sf \left[1 - (1 - F)^{g_q} \right] \tag{17-21}$$

s is the saturation flow rate of the major-street through lanes

The minimum platooned flow rate, $v_{c,min}$, is at least $3,600N/t_c$, where N is the number of through lanes per direction on the major street. It is assumed to be equal to $1,000N$ veh/h on the basis of simulation data (10).

The duration of the blocked period for either the through movement or the protected left-turn movement is computed by using Equation 17-22.

$$t_{p,i} = g_q - \frac{\ln \left[\left(1 - \frac{v_{c,min}}{sf} \right) \left(\frac{v_{c,max} - v_{prog} R_{pf}}{v_{c,min} - v_{prog} R_{pf}} \right) \right]}{\ln(1-F)}$$

If $v_{c,min} \geq sf$ or $v_{c,max} \leq v_{c,min}$, then

$$t_{p,i} = 0 \tag{17-22}$$

If $v_{c,min} < sf$ and $v_{c,max} \geq v_{c,min}$ and $v_{prog} R_{pf} \geq v_{c,min}$, then

$$t_{p,i} = C \left(\frac{v_{prog}}{v_{c,min}} \right)$$

The subscript i is set equal to T when the blocked period caused by the through movement platoon is computed. The subscript is set to L when the blocked period caused by the protected left movement platoon is computed.

The proportion of time blocked is computed by using Equation 17-23, considering both the through movement and the protected left-turn movement platoons:

$$p_i = \frac{t_{p,T} + t_{p,L}}{C} \tag{17-23}$$

where i denotes either Movement 2 or Movement 5. Note that p_i cannot exceed one.

Platoon Event Periods - Computation 3

This computation is used to determine the proportion of the analysis period during which each of the four flow regimes exist. In particular, the proportion of the analysis period that is unblocked for each minor movement is determined.

The existence of a traffic signal on both upstream approaches will result in an overlapping platoon structure at the TWSC intersection. Depending on the signal timing parameters, a range of cases may present themselves, from a best case of simultaneous platoons from both directions to a worst case of alternating platoons from each direction. An average case results in a partial overlap of the platoons. Exhibit 17-14 illustrates these cases and can be used to represent the expected pattern averaged over the analysis period.

If p_2 and p_5 represent the proportion of the analysis period during which Movements 2 and 5 (and their corresponding turning movements) are blocking the TWSC intersection, respectively, the proportion of the analysis period during which blockages exist can be computed. The dominant and subordinate platoons are determined by Equations 17-24 and 17-25.

$$p_{dom} = \text{Max}(p_2, p_5) \tag{17-24}$$

$$p_{subo} = \text{Min}(p_2, p_5) \tag{17-25}$$

Unconstrained conditions exist if there is some period of time during which neither platoon is present. This condition is defined by Equation 17-26:

$$p_{dom} + (p_{subo}/2) \leq 1 \tag{17-26}$$

The constrained condition exists if one or both platoons are always present. This condition is defined by Equation 17-27.

If two-stage gap acceptance is applicable, repeat Computations 3, 4, and 5 for the two-stage process for Movements 7, 8, 10, and 11

$$\rho_{dom} + (\rho_{sub}/2) > 1$$

(17-27)

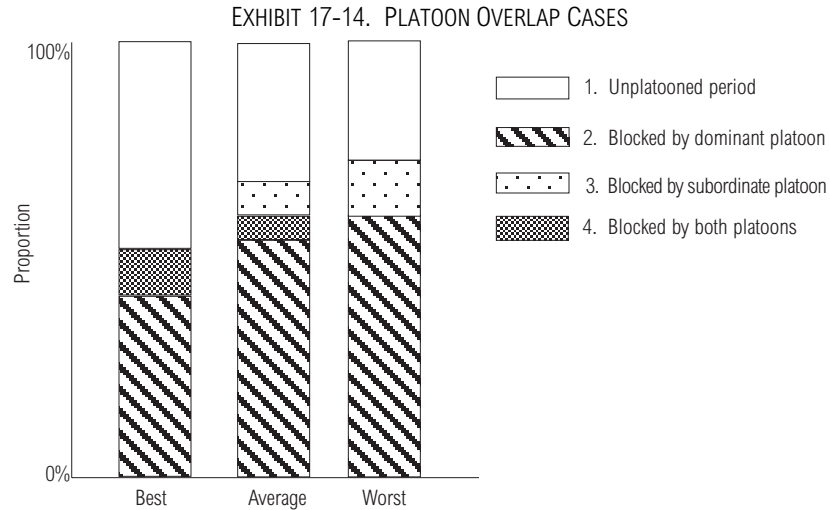

Exhibit 17-15 indicates the proportion of the analysis period for each of the four flow regimes for the average case. Exhibit 17-15 is used to determine the proportion of the analysis period that is blocked and unblocked for each minor movement. The results for each minor movement for the average case are given in Exhibit 17-16.

EXHIBIT 17-15. PROPORTION OF ANALYSIS PERIOD FOR EACH FLOW REGIME (AVERAGE CASE)

Flow Regime	Unconstrained Condition	Constrained Condition
1 - no platoons	$1 - (\rho_{dom} + \rho_{sub}/2)$	0
2 - dominant platoon only	$\rho_{dom} - \rho_{sub}/2$	$1 - \rho_{sub}$
3 - subordinate platoon only	$\rho_{sub}/2$	$1 - \rho_{dom}$
4 - both platoons	$\rho_{sub}/2$	$\rho_{dom} + \rho_{sub} - 1$

EXHIBIT 17-16. PROPORTION OF ANALYSIS PERIOD UNBLOCKED FOR EACH MINOR MOVEMENT (AVERAGE CASE)

Proportion Unblocked for Movement, p_x	Unconstrained Condition	Constrained Condition
p_1	$1 - \rho_5$	$1 - \rho_5$
p_4	$1 - \rho_2$	$1 - \rho_2$
p_7	$1 - (\rho_{dom} + \rho_{sub}/2)$	0
p_8	$1 - (\rho_{dom} + \rho_{sub}/2)$	0
p_9	$1 - \rho_2$	$1 - \rho_2$
p_{10}	$1 - (\rho_{dom} + \rho_{sub}/2)$	0
p_{11}	$1 - (\rho_{dom} + \rho_{sub}/2)$	0
p_{12}	$1 - \rho_5$	$1 - \rho_5$

Conflicting Flows During Unblocked Period - Computation 4

The flow for the unblocked period (no platoons) is determined in this step. This flow becomes the conflicting flow for the subject movement and is used to compute the capacity for this movement.

The conflicting flow for movement x during the unblocked period is given by Equation 17-28.

$$v_{c,u,x} = \begin{cases} \frac{v_{c,x} - s(1-p)}{p_x} & \text{if } v_{c,x} > s(1-p_x) \\ 0 & \text{otherwise} \end{cases} \quad (17-28)$$

s is average saturation flow rate of Major Movements 2 and 5 while performing single-stage analysis

where

- $v_{c,x}$ = total conflicting flow for movement x as determined from Exhibit 17-4;
- s = saturation flow rate of the major movement, which is the conflicting flow for movement x during the blocked period; and
- p_x = proportion of time that the subject movement x is unblocked by the major-street platoon, which is determined from Exhibit 17-16.

Capacity During Unblocked Period - Computation 5

The capacity of the subject movement x, accounting for the effect of platooning, is given by Equation 17-29:

$$c_{plat,x} = p_x c_{r,x} \quad (17-29)$$

Adjust c_{plat} to account for impedance, shared lane and flared approach

where

- p_x = proportion of time that movement x is unblocked by a platoon; and
- $c_{r,x}$ = capacity of movement x assuming random flow during the unblocked period, using the conflicting flow, $v_{c,u,x}$, computed for this unblocked period, and Equation 17-3.

Two-Stage Gap Acceptance

In this procedure, the intersection is assumed to consist of two parts, with the minor-street traffic crossing the major street in two phases. Between the partial intersections I and II there is a storage space for m vehicles (see Exhibit 17-17). This area has to be passed by the left-turner from the major street (movement v_1 or v_4) and the minor through or left-turn traffic. It is assumed that the usual rules for TWSC intersections are applied by drivers at the intersections. Thus, the major through traffic has priority over all other movements.

The conflicting flow rates are defined for each minor-stream movement that uses the two-stage gap acceptance process on the basis of Exhibit 17-4 for both the first-stage and the second-stage movements. For the first stage, the conflicting flows consist of the major-street flows from the left. For the second stage, the conflicting flows consist of the major-street flows from the right. The streams included in each conflicting flow are shown in Exhibit 17-4.

The capacity for the subject movement is computed assuming a single-stage gap acceptance process through the entire intersection. Next, the capacities for Stage I, c_I , and Stage II, c_{II} , are computed using the appropriate values of critical gap and follow-up time for the two-stage gap acceptance process from Exhibit 17-5. Note that c_I is the capacity considering conflicting flows v_I and that c_{II} is the capacity considering conflicting flows v_{II} (see Exhibit 17-4), and that they are determined by using Equation 17-3.

The capacity for the subject movement considering the two-stage gap acceptance process is computed as follows. An adjustment factor a and an intermediate variable y are computed using Equations 17-30 and 17-31.

Adjustment for the two-stage gap acceptance is applicable to Movements 7, 8, 10, and 11

$$a = 1 - 0.32e^{-1.3\sqrt{m}} \quad \text{for } m > 0 \quad (17-30)$$

$$y = \frac{c_I - c_{m,x}}{c_{II} - v_L - c_{m,x}} \quad (17-31)$$

c_I , c_{II} , and $c_{m,x}$ are capacities after being adjusted for upstream signals and impedance. Use v_1 when considering Movements 7 and 8 and v_4 when considering Movements 10 and 11.

where

- m = number of storage spaces in the median;
- c_I = movement capacity for the Stage I process (veh/h);
- c_{II} = movement capacity for the Stage II process (veh/h);
- v_L = major left-turn flow rate, either V_1 or V_4 (veh/h); and
- $c_{m,x}$ = capacity of subject movement considering the total conflicting flow rate for both stages of a two-stage gap acceptance process.

EXHIBIT 17-17. TWO-STAGE GAP ACCEPTANCE INTERSECTION

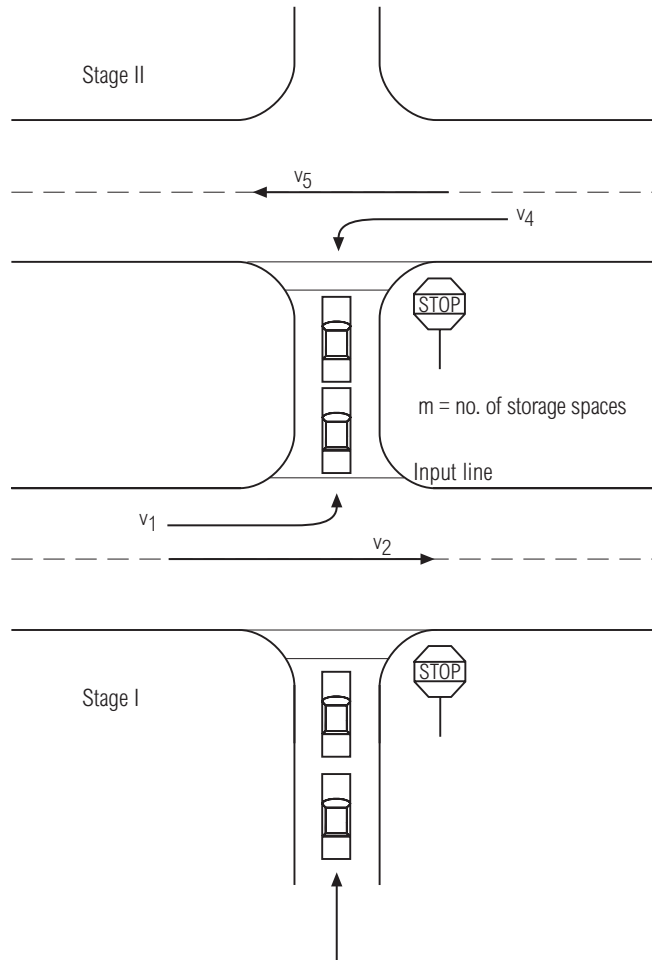

The total capacity, c_T , of the intersection for the subject movement considering the two-stage gap acceptance process is computed using Equations 17-32 and 17-33.

For $y \neq 1$,

$$c_T = \frac{a}{y^{m+1} - 1} \left[y(y^m - 1)(c_{II} - v_L) + (y - 1)c_{m,x} \right] \quad (17-32)$$

For $y = 1$,

$$c_T = \frac{a}{m + 1} \left[m(c_{II} - v_L) + c_{m,x} \right] \quad (17-33)$$

Flared Minor-Street Approaches

If n is defined as the number of spaces for passenger cars belonging to one movement that can queue at the stop line without obstructing other movements, it is clear that with $n > 0$, the capacity of the minor-street approach is increased compared with the shared-lane condition. With an increase in n , the total capacity approaches the ideal case in which each movement has its own infinitely long lane. In the situation shown in Exhibit 17-18, the flared pavement provides space for two vehicles to proceed, one alongside the other. In this case, the storage can be defined as $n = 1$, since one additional vehicle is able to reach the stop line.

EXHIBIT 17-18. CAPACITY OF FLARED APPROACHES

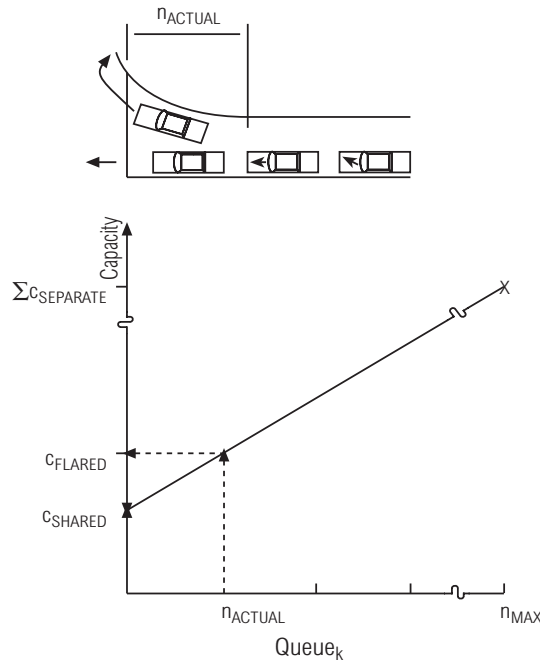

The actual capacity resulting from this configuration will be greater than in the case where the right-turn vehicles must share the lane and less than in the case where the vehicles have separate lanes. The analyst must compute the average queue length for each movement, considering the separate lane case, and consider the actual storage available in the flared-lane area. Exhibit 17-18 shows how the actual capacity can be interpolated using this information.

First, the average queue length for each movement sharing the right lane of the approach is computed by using Equation 17-34, assuming that the right-turn movement operates in one lane and that the other traffic in the right lane (upstream of the flare) operates in another, separate lane.

$$Q_{sep} = \frac{d_{sep} v_{sep}}{3600} \tag{17-34}$$

where

- Q_{sep} = average queue length for the movement considered as a separate lane (veh),
- d_{sep} = control delay for the movement considered as a separate lane (s), and
- v_{sep} = flow rate for the movement (veh/h).

Next, the required length of the storage area such that the approach would operate effectively as separate lanes is computed using Equation 17-35. This is the maximum value of the queue lengths computed for each separate movement plus one vehicle.

$$n_{Max} = \text{Max}_i \text{ round}(Q_{sep,i} + 1) \quad (17-35)$$

where

- $Q_{sep,i}$ = average queue length for movement i considered as a separate lane;
- round = round-off operator, rounding the quantity in parentheses to the nearest integer;
- Max = operator determining the maximum value of the various values of $Q_{sep,i}$; and
- n_{Max} = length of the storage area such that the approach would operate as separate lanes.

Finally, the capacity of the approach is computed, taking into account the flare. The capacity is interpolated as shown in Exhibit 17-18. A straight line is established using values of two points: $(\sum c_{sep}, n_{Max})$ and $(c_{SH}, 0)$. The interpolated value of c_{act} is computed using Equation 17-36.

$$c_{act} = \begin{cases} (\sum_i c_{sep} - c_{SH}) \frac{n}{n_{Max}} + c_{SH} & \text{if } n \leq n_{Max} \\ \sum_i c_{sep} & \text{if } n > n_{Max} \end{cases} \quad (17-36)$$

where

- c_{act} = actual capacity of flared approach (veh/h);
- c_{sep} = capacity of the approach if both lanes were long (veh/h) [this is the capacity of right-turning traffic operating as a separate lane and the capacity of the other traffic in the right lane (upstream of the flare) operating as a separate lane];
- c_{SH} = capacity of the lane when all traffic is in one lane, in which all traffic in the right lane is considered to share one lane (veh/h); and
- n = actual storage area as defined in Exhibit 17-18.

The actual capacity (c_{act}) must be greater than c_{SH} but less than or equal to c_{sep} .

ESTIMATING QUEUE LENGTHS

Estimation of queue length is an important consideration at unsignalized intersections. Theoretical studies and empirical observations have demonstrated that the probability distribution of queue lengths for any minor movement at an unsignalized intersection is a function of the capacity of the movement and the volume of traffic being served during the analysis period. Exhibit 17-19 can be used to estimate the 95th-percentile queue length for any minor movement at an unsignalized intersection during the peak 15-min period on the basis of these two parameters (I).

The mean queue length is computed as the product of the average delay per vehicle and the flow rate for the movement of interest. The expected total delay (vehicle-hours per hour) equals the expected number of vehicles in the average queue; that is, the total hourly delay and the average queue are numerically identical. For example, 4 vehicle-hours/hour of delay can be used interchangeably with an average queue length of four (vehicles) during the hour.

$\sum c_{sep}$ is the sum of the capacities of the right-turning traffic operating as a separate lane and the capacity of the other traffic in the right lane (upstream of the flare) operating in a separate lane

EXHIBIT 17-19. 95TH-PERCENTILE QUEUE LENGTH

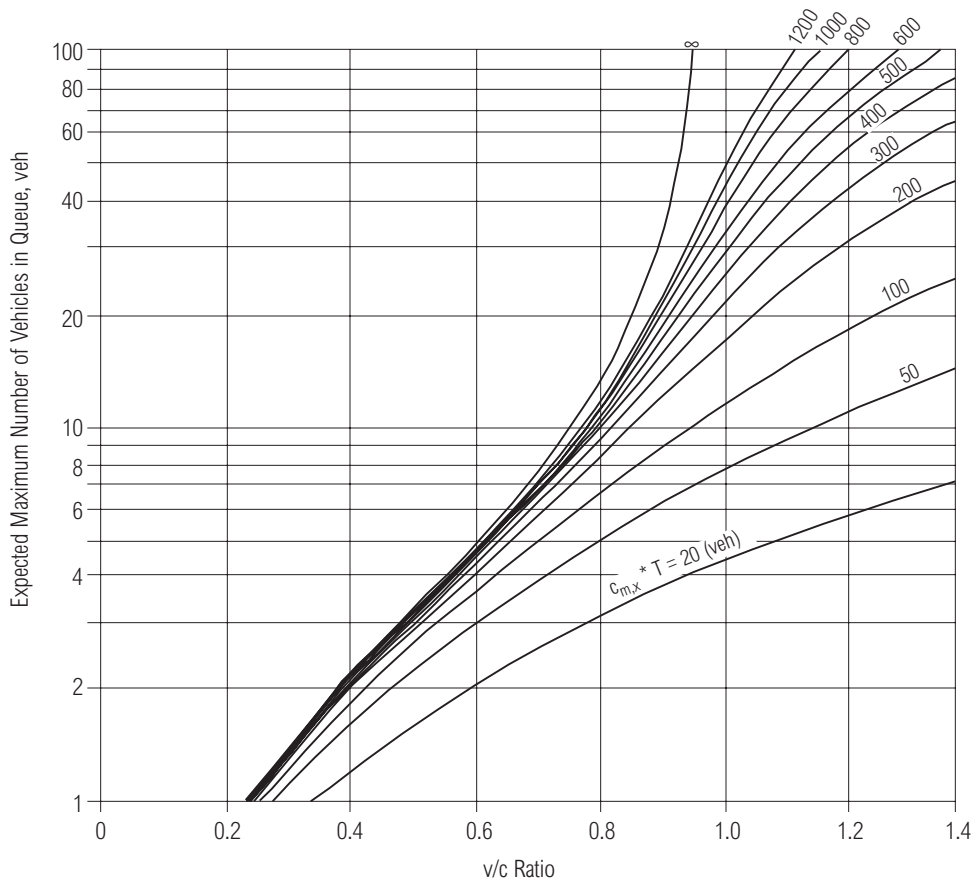

Relationships between expected queue length and the total daily volume exist only when unsaturated systems are analyzed

Equation 17-37 is used to calculate the 95th-percentile queue.

$$Q_{95} \approx 900T \left[\frac{v_x}{c_{m,x}} - 1 + \sqrt{\left(\frac{v_x}{c_{m,x}} - 1 \right)^2 + \frac{\left(\frac{3600}{c_{m,x}} \right) \left(\frac{v_x}{c_{m,x}} \right)}{150T}} \right] \left(\frac{c_{m,x}}{3600} \right) \quad (17-37)$$

where

- Q_{95} = 95th-percentile queue (veh),
- v_x = flow rate for movement x (veh/h),
- $c_{m,x}$ = capacity of movement x (veh/h), and
- T = analysis time period (h) ($T = 0.25$ for a 15-min period).

CONTROL DELAY

The delay experienced by a motorist is made up of a number of factors that relate to control, geometrics, traffic, and incidents. Total delay is the difference between the travel time actually experienced and the reference travel time that would result during base conditions, in the absence of incident, control, traffic, or geometric delay. In Chapters 16 and 17 of this manual, only that portion of total delay attributed to control measures, either traffic signals or stop signs, is quantified. This delay is called control delay, and its use is consistent between Chapters 16 and 17. Control delay includes initial deceleration delay, queue move-up time, stopped delay, and final acceleration delay. With respect to

field measurements, control delay is defined as the total elapsed time from the time a vehicle stops at the end of the queue to the time the vehicle departs from the stop line. This total elapsed time includes the time required for the vehicle to travel from the last-in-queue position to the first-in-queue position, including deceleration of vehicles from free-flow speed to the speed of vehicles in queue.

Average control delay for any particular minor movement is a function of the capacity of the approach and the degree of saturation. The analytical model used to estimate control delay (Equation 17-38) assumes that the demand is less than capacity for the period of analysis. If the degree of saturation is greater than about 0.9, average control delay is significantly affected by the length of the analysis period. In most cases, the recommended analysis period is 15 min. If demand exceeds capacity during a 15-min period, the delay results calculated by the procedure may not be accurate. In this case, the period of analysis should be lengthened to include the period of oversaturation.

$$d = \frac{3600}{c_{m,x}} + 900T \left[\frac{v_x}{c_{m,x}} - 1 + \sqrt{\left(\frac{v_x}{c_{m,x}} - 1 \right)^2 + \frac{\left(\frac{3600}{c_{m,x}} \right) \left(\frac{v_x}{c_{m,x}} \right)}{450T}} \right] + 5 \quad (17-38)$$

where

- d = control delay (s/veh),
- v_x = flow rate for movement x (veh/h),
- $c_{m,x}$ = capacity of movement x (veh/h), and
- T = analysis time period (h) ($T = 0.25$ for a 15-min period).

A constant value of 5.0 s is used to reflect delay during deceleration

The constant value of 5 s/veh is included in Equation 17-38 to account for the deceleration of vehicles from free-flow speed to the speed of vehicles in queue and the acceleration of vehicles from the stop line to free-flow speed. This equation is depicted graphically in Exhibit 17-20 for a discrete range of capacities and a 15-min analysis period.

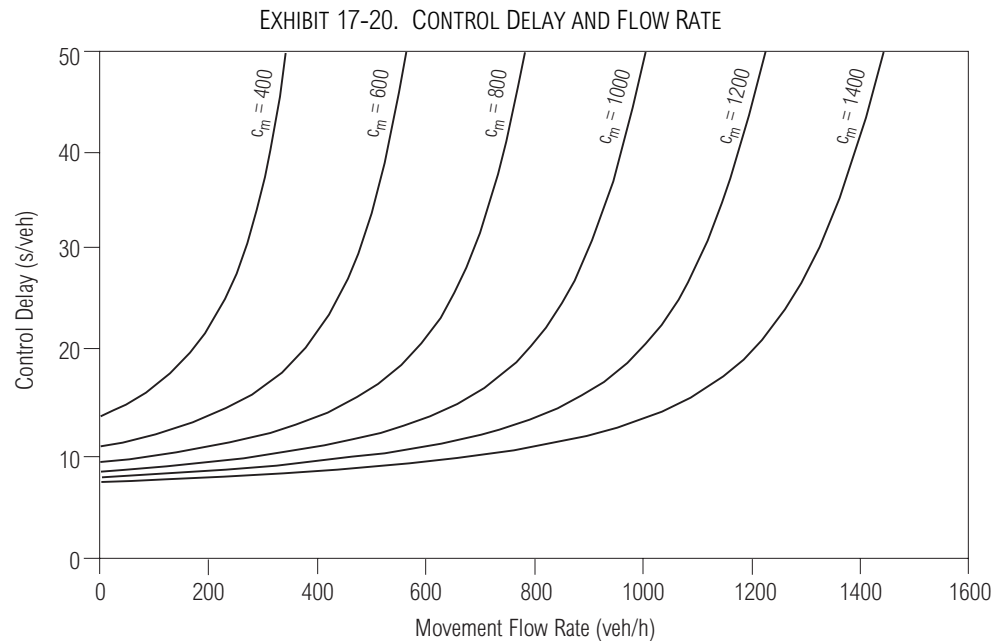

OTHER RELEVANT DELAY ESTIMATES

Delay to Rank 1 Vehicles

The effect of a shared lane on the major-street approach where left-turn vehicles may block Rank 1 through or right-turning vehicles can be significant. If no exclusive left-turn pocket is provided on the major street, a delayed left-turn vehicle may block the Rank 1 vehicles behind it. This will delay not only Rank 1 vehicles but also lower-ranked streams. While the delayed Rank 1 vehicles are discharging from the queue formed behind a left-turning vehicle, they impede lower-ranked movements with which they conflict.

Field observations have shown that such a blockage effect is usually very small, because the major street usually provides enough space for the blocked Rank 1 vehicle to sneak by or bypass the left-turning vehicle. At a minimum, incorporating this effect requires the proportion of Rank 1 vehicles being blocked and the average delay to the major-street left-turning vehicles that are blocking through vehicles.

In the simplest procedure, the proportion of major Rank 1 vehicles not being blocked (i.e., in a queue-free state) is given by $p_{0,j}^*$ in Equation 17-16 ($p_{0,j}^*$ should be substituted for the major left-turn factor $p_{0,j}$ in Equation 17-6 in calculating the capacity of lower-ranked movements that conflict). Therefore, the proportion of Rank 1 vehicles being blocked is $1 - p_{0,j}^*$.

The average delay to Rank 1 vehicles on this approach is computed by Equation 17-39.

$$d_{Rank1} = \begin{cases} \frac{(1 - p_{0,j}^*)d_{M,LT} \left(\frac{v_{i,1}}{N} \right)}{v_{i,1} + v_{i,2}} & N > 1 \\ (1 - p_{0,j}^*)d_{M,LT} & N = 1 \end{cases} \quad (17-39)$$

$\frac{v_{i,1}}{N}$ becomes $\frac{v_{i,2}}{N}$
if $v_{i,1} = 0$

where

- d_{Rank1} = delay to Rank 1 vehicles (s/veh),
- N = number of through lanes per direction on the major street,
- $p_{0,j}^*$ = proportion of Rank 1 vehicles not blocked (Equation 17-16),
- $d_{M,LT}$ = delay to major left-turning vehicles (s/veh),
- $v_{i,1}$ = major-street through vehicles in shared lane (veh/h), and
- $v_{i,2}$ = major-street right-turning vehicles in shared lane (veh/h).

$d_{M,LT}$ is estimated using Equation 17-38

Note that on a multilane road, only the major-street volumes in the lane that may be blocked should be used in the calculation as $v_{i,1}$ and $v_{i,2}$. On multilane roads if it is assumed that blocked Rank 1 vehicles do not bypass the blockage by moving across into other through lanes (a reasonable assumption under conditions of high major-street flows), then $v_{i,1} = v_1/N$. Because of the unique characteristics associated with each site, the decision on whether to account for this effect is left to the analyst.

Intersection and Approach Delay

The control delay for all vehicles on a particular approach can be computed as the weighted average of the control delay estimates for each movement on the approach. Equation 17-40 is used for the computation.

$$d_A = \frac{d_r v_r + d_t v_t + d_l v_l}{v_r + v_t + v_l} \quad (17-40)$$

where

- d_A = control delay on the approach (s/veh);
- d_r, d_t, d_l = computed control delay for the right-turn, through, and left-turn movements, respectively (s/veh); and
- v_r, v_t, v_l = volume or flow rate of right-turn, through, and left-turn traffic on the approach, respectively (veh/h).

Similarly, the intersection control delay can be computed using Equation 17-41:

$$d_I = \frac{d_{A,1}v_{A,1} + d_{A,2}v_{A,2} + d_{A,3}v_{A,3} + d_{A,4}v_{A,4}}{v_{A,1} + v_{A,2} + v_{A,3} + v_{A,4}} \quad (17-41)$$

where

- $d_{A,x}$ = control delay on approach x (s/veh), and
- $v_{A,x}$ = volume or flow rate on approach x (veh/h).

In applying Equations 17-40 and 17-41, the delay for all major-street movements of Rank 1 is assumed to be 0 s/veh.

INTERPRETING RESULTS

Shared Lanes

A movement, most often a left-turn movement, can sometimes have a poorer level of service if it is given a separate lane than if it shares a lane with another movement (usually a through movement). This is not inconsistent in terms of the stated criteria. Left-turn movements will generally experience longer control delays than other movements because of the nature and priority of the movement. If left turns are placed in a shared lane, the control delay for vehicles in that lane may indeed be less than the control delay for left turns in a separate lane. However, if delay for all vehicles is considered, providing separate lanes will result in lower total delay.

Performance Measures

LOS F occurs when there are not enough gaps of suitable size to allow a minor-street demand to safely cross through traffic on the major street. This is typically evident from extremely long control delays experienced by minor-street traffic and by queuing on the minor approaches. The method, however, is based on a constant critical gap size.

LOS F may also appear in the form of drivers on the minor street selecting smaller than usual gaps. In such cases, safety may be a problem, and some disruption to the major traffic stream may result. Note that LOS F may not always result in long queues but in adjustments to normal gap acceptance behavior.

At TWSC intersections the critical movement, often the minor-street left turn, may control the overall performance of the intersection. The lower threshold for LOS F is set at 50 s of delay per vehicle. In some cases, the delay equations will predict delays greater than 50 s for minor-street movements under very low-volume conditions on the minor street (less than 25 veh/h). Note that the LOS F threshold is reached with a movement capacity of approximately 85 veh/h or less.

This analysis procedure assumes random arrivals on the major street. For a typical four-lane major street with average daily traffic volumes in the range of 15,000 to 20,000 vehicles per day (peak hour with 1,500 to 2,000 veh/h), the delay equation will predict greater than 50 s of delay (LOS F) for many urban TWSC intersections that allow minor-street left-turn movements. LOS F will be predicted regardless of the volume of minor-street left-turning traffic. Even with an LOS F estimate, most low-volume minor-street approaches would not meet any of the MUTCD volume or delay warrants for signalization. As a result, analysts who use the HCM LOS thresholds to determine the design adequacy of TWSC intersections should do so with caution.

Some unsignalized intersections estimated to operate at LOS F will not meet MUTCD warrants for signalization

In evaluating the overall performance of TWSC intersections it is important to consider measures of effectiveness in addition to delay, such as v/c ratios for individual movements, average queue lengths, and 95th-percentile queue lengths. By focusing on a single measure of effectiveness for the worst movement only, such as delay for the minor-street left turn, users may make less effective traffic control decisions.

DETERMINING INTERSECTION CONTROL TYPE

Determination of an appropriate control for an intersection, either signal control or a form of stop control, can be accomplished by integrating information from several sources. Traffic signal warrants, LOS analyses, accident data, and public complaints form the basis for a decision to signalize an intersection or to use stop control. Three documents, among others, are available to assist the traffic engineer in this assessment: the MUTCD, the ITE *Traffic Engineering Handbook* (TEH) (12), and the HCM.

The MUTCD provides a set of warrants for determining the appropriate conditions for signalization, two-way stop control, and all-way stop control. The following 11 signal warrants are provided in the MUTCD: minimum vehicular volume, interruption of continuous traffic, minimum pedestrian volume, school crossings, progressive movement, accident experience, systems, combination of warrants, 4-h volumes, peak-hour delay, and peak-hour volume. Although only one of these warrants must be met before a signal is recommended, traffic engineers should ideally consider all these aspects in making a decision concerning an intersection control type. This set of warrants represents guidance based on collective professional consensus accumulated over many decades. Practicing traffic engineers can refer to these warrants whenever issues concerning decisions on intersection control types arise.

The TEH points out that traffic signals do not always increase safety and reduce delay. Therefore, it may also be appropriate to consider all-way stop control. The TEH cites the following warrants for all-way stop control (from the MUTCD):

1. As an interim measure that can be installed quickly while arrangements are being made for a warranted traffic signal;
2. When an accident problem, as indicated by five or more reported accidents in a 12-month period, is of a type that can be corrected using a multiway stop and less restrictive controls have not been successful; and
3. For the following minimum traffic volumes: (a) the total vehicle volume entering the intersection from all approaches averages at least 500 veh/h for any 8 h of an average day, and (b) the combined vehicular and pedestrian volume from minor streets averages at least 200 units/h for the same 8 h with an average delay to minor-street traffic of at least 30 s/veh during the maximum hour [but when the 85th-percentile approach speed of the major-street traffic exceeds 40 mi/h, minimum volume warrants are 70 percent of the requirement in (a)].

Concerning traffic signal warrants, the TEH states:

Traffic signals that are appropriately justified, properly designed, and effectively operated can be expected to achieve one or more of the following:

1. To effect orderly traffic movement through an appropriate assignment of right-of-way,
2. To provide for the progressive flow of a platoon of traffic along a given route,
3. To interrupt heavy traffic at intervals to allow pedestrians and cross-street traffic to cross or to enter the main-street flow,
4. To increase the traffic handling ability of an intersection, or
5. To reduce the frequency of occurrence of certain types of accidents.

The analyses available in the HCM may be valuable inputs to the determination of control types. Several sources should be synthesized in arriving at a decision.

Guidelines on required inputs and estimated values are in Chapter 10

Computational sequence is by order of priority of movements

III. APPLICATIONS - PART A

The analysis of TWSC intersections is generally applied to existing locations either to evaluate operational conditions under current traffic demands or to estimate the effects of anticipated demands. The methodology is specifically structured to yield an LOS and an estimate of average control delay for an existing or planned TWSC intersection. Design applications are treated as trial-and-error computations based on anticipated improvements to an existing intersection or on the projected design of a new intersection.

Exhibit 17-21 shows the steps involved in the procedure. The procedure is divided into three modules. In the first module, Initial Calculations, the analyst uses Worksheets 1 through 5 to record input conditions, compute the critical gap and follow-up time, and determine the flow patterns that result from any upstream signalized intersections that may affect the capacity of the subject intersection. The analyst uses Worksheets 6 through 9 from the second module, Capacity Calculations, to compute the capacity of each movement and make adjustments for the effects of two-stage gap acceptance, shared lanes, or flared minor-street approaches. The third module, Delay and LOS Calculations, includes worksheets to compute the delay, queue length, and LOS for each approach.

SEQUENCE OF CAPACITY COMPUTATIONS

Since the methodology is based on prioritized use of gaps by vehicles at a TWSC intersection, it is important that computations be made in a precise order. The computational sequence is the same as the priority of gap use, and movements are considered in the following order:

1. Right turns from the minor street,
2. Left turns from the major street,
3. Through movements from the minor street, and
4. Left turns from the minor street.

COMPUTATIONAL STEPS

Eleven worksheets are included in an appendix. The following steps describe how computations are made and summarized using the worksheets. The procedure is the same for three-leg and four-leg intersections.

Geometrics and Movements (Worksheet 1)

The sketch shows designated movement numbers, v_1 through v_6 denoting major-street movements and v_7 through v_{12} denoting minor-street movements. Lane arrangement, street name, grade, and other pertinent geometric data are entered in the right-hand sketch. General information and site information are entered in appropriate fields.

Volume Adjustments (Worksheet 2)

Measured or forecast volumes (veh/h) for each movement are used to compute hourly flow rates by dividing volume by PHF. Proportion of heavy vehicles (HV) is the percentage of HVs divided by 100 and is used to compute the critical gap and the follow-up time. If pedestrians are present, the percentage of time that they block a lane on an approach (denoted as percent blockage, f_p) is determined using Equation 17-11.

Site Characteristics (Worksheet 3)

Information on lanes and traffic movements is entered. For example, if Movements 1, 2, and 3 all share a single lane and there are no other lanes on the approach, the string 1, 2, 3 would be entered in the Lane 1 column. The grade for each approach and presence of channelized right-turn lanes are noted.

EXHIBIT 17-21. TWSC INTERSECTION METHODOLOGY

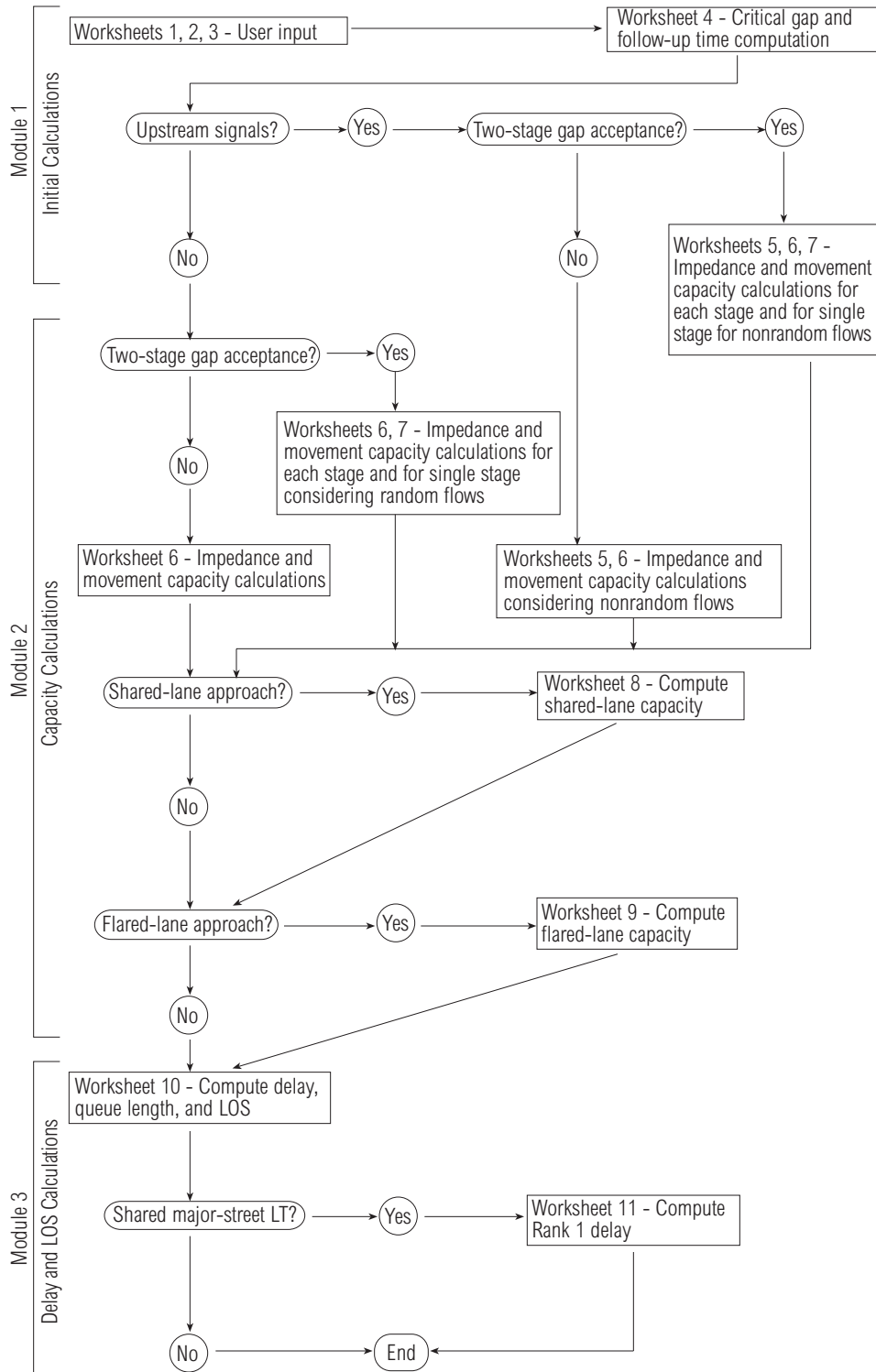

Definitions of m and n are given in corresponding sections in the methodology (see Exhibits 17-17 and 17-18). Median type (raised or TWLTL) will be used to determine the platoon dispersion factor in accounting for the effect of upstream signals. If there is an upstream signalized intersection within 0.25 mi of the intersection on the major street,

required data to account for platooning are shown. Note that S_2 denotes a signal upstream of Movement 2 and that S_5 denotes a signal upstream of Movement 5. Saturation flow rate of the travel lanes between the upstream signals and the subject TWSC intersection is noted.

If the analyst needs to compute delay to major-street vehicles resulting from sharing a lane with major-street left-turning vehicles, relevant data are entered in the bottom section of Worksheet 3.

Critical Gap and Follow-Up Time (Worksheet 4)

Exhibit 17-5 and Equations 17-1 and 17-2 are used to compute the critical gap and follow-up time, which is used in Equation 17-1 to determine potential capacities. If two-stage gap acceptance exists, two sets of critical gap are calculated using $t_{c,T}$ values of 0.0 and 1.0, respectively.

Effect of Upstream Signals (Worksheet 5)

Worksheet 5 is used to compute the potential capacities affected by platooning from upstream signalized intersections that are within 0.25 mi of the TWSC intersection. The worksheet has five parts, a through e.

Worksheet 5a is used to determine the time required for the queue to clear from the upstream signalized intersection for both the through movement and the protected left-turn movement. For determining the proportion of vehicles arriving on green (Equation 17-17), R_p as a function of the arrival type can be obtained from Chapter 16.

Worksheet 5b is used to determine the proportion of time that the TWSC intersection is blocked by the passing platoon from the upstream signalized intersection. The following points should be noted. Median type from Worksheet 3 and Exhibit 17-13 are used to determine the platoon dispersion factor, α . Unit conversion factors are needed for D and S_{prog} to obtain the travel time, t_a . In computing f ($f = v_{prog}/v_c$), v_c is typically the major-street approach flow rate.

Worksheet 5c is used to determine the platoon event periods and the proportion of time that is unblocked for each minor-stream movement. The dominant and subordinate platoons are computed using Equations 17-24 and 17-25. Equations 17-26 and 17-27 are used to determine whether the condition is unconstrained (there is some time during which no platoons are present) or constrained (one or more platoons are always present). The proportion of time that is unblocked is determined for each minor movement, p_x , using Exhibit 17-16 or equations given for the two-stage gap acceptance process.

Worksheet 5d is used to compute the conflicting flows during the unblocked period for each minor movement. The conflicting flow, $v_{c,x}$, is determined from Exhibit 17-4; s is the saturation flow rate of the major-street through lanes; and values of p_x are from Worksheet 5c. The conflicting flow for movement x during the unblocked period, $v_{c,u,x}$, is computed using Equation 17-28. Similar computations are repeated for the two-stage gap acceptance process if applicable.

Worksheet 5e is used to determine the capacity for the subject movement during the unblocked period. The proportion of time that is unblocked for each minor movement, p_x , is from Worksheet 5c. The capacity for movement x during the unplatooned period (assuming random flow), $c_{r,x}$, is computed using Equation 17-3.

Impedance and Capacity Calculation (Worksheet 6)

The capacity for each movement is computed using Worksheet 6. Some equations are shown on the worksheet. Flow rates are keyed to Worksheets 1 and 2.

Computations proceed in the prescribed order, considering first the right turns from the minor street, followed by left turns from the major street, through movements from the minor street, and left turns from the minor street. The user should solve for all movements before proceeding to the next step. For example, both right turns in Step 1

should be computed before proceeding to Step 2. For a four-leg intersection, use Steps 1, 2, 3, and 4, and for T-intersections, use Steps 1, 2, and 5.

Two-Stage Gap Acceptance (Worksheet 7)

Worksheets 7a and 7b are used in place of Steps 3 and 4 in Worksheet 6 to compute the potential capacity when a two-stage gap acceptance process exists. The sequence of calculations is similar to that described for Worksheet 6, except that there are now three parts, two for the two-stage process and one for the single-stage process. The conflicting flow for the single stage is the sum of those for Stages I and II of the two-stage process. Parameters a and y are computed using Equations 17-30 and 17-31; Equation 17-32 or 17-33 is used to compute the two-stage movement capacity.

Shared-Lane Capacity (Worksheet 8)

Equation 17-15 is used to compute shared-lane capacity on Worksheet 8.

Effect of Flared Minor-Street Approaches (Worksheet 9)

Worksheet 9 is used to compute the effect of minor-street flared approaches. Whereas three columns are provided on the worksheet (for all minor movements), only movements that share the right lane on the subject approach are included in the computation.

Control Delay, Queue Length, Level of Service (Worksheet 10)

Worksheet 10 is used to compute control delay, average queue length, and level of service. Control delay for each movement can be estimated from Exhibit 17-20 or Equation 17-38. The 95th-percentile queue length is determined from Exhibit 17-19 or Equation 17-37. LOS is then determined from Exhibit 17-2.

Delay to Rank 1 Vehicles (Worksheet 11)

Worksheet 11 is used to compute the delay to Rank 1 vehicles using Equation 17-39.

PLANNING AND DESIGN APPLICATIONS

This chapter provides a detailed means of evaluating the performance of a TWSC intersection. An analyst may desire to estimate the LOS for a future time horizon. Typically, only a limited amount of input data are available.

A planning analysis requires geometric and traffic flow data. The base values of critical gap and follow-up time from Exhibit 17-5 are used. The effects of upstream signals, two-stage gap acceptance, and flared right-turn approaches are normally not accounted for in a planning analysis. However, if these data are available, they can be included.

The planning analysis uses the same worksheets as a detailed analysis, with some exceptions as noted below.

- Worksheet 1 is used to describe basic conditions.
- Worksheet 2 is used to summarize the vehicle volumes. Pedestrian volumes are generally not used.
- Worksheet 3 is used to note the lane designation for each movement. Generally, the corrections for flared minor-street approach, median storage, and upstream signals are not included.
- Worksheet 4 is generally not used, since the base values from Exhibit 17-4 are used without adjustment.
- Worksheet 5 is not used, since the effect of upstream signals is generally not included in a planning analysis.
- Worksheet 6 is used to compute the movement capacities.
- Worksheet 7 is used to include the effects of two-stage gap acceptance when there is a divided roadway or TWLTL on the major street.

- Worksheet 8 is used to compute shared-lane capacities, if more than one movement shares the same minor-street approach.
- Worksheet 9 is not used, since the effect of flared minor-street approaches is generally not included.
- Worksheet 10 is not used, since the impedance and delay for the major through movements are not accounted for in a planning analysis.
- Worksheet 11 is used to compute capacity, delay, and LOS.

The detailed analysis procedure described earlier in this chapter is normally not used for design purposes. However, through iteration, the analyst can use a given set of traffic flow data to determine the number of lanes that would be required to produce a given level of service.

PART B. ALL-WAY STOP-CONTROLLED INTERSECTIONS

I. INTRODUCTION - PART B

This section of Chapter 17 presents procedures for analyzing all-way stop-controlled (AWSC) intersections (*I*). A glossary of symbols, including those used for AWSC intersections, is found in Chapter 6.

II. METHODOLOGY - PART B

LEVEL-OF-SERVICE CRITERIA

The level-of-service criteria are given in Exhibit 17-22. The criteria for AWSC intersections have different threshold values than do those for signalized intersections primarily because drivers expect different levels of performance from distinct types of transportation facilities. The expectation is that a signalized intersection is designed to carry higher traffic volumes than an AWSC intersection. Thus a higher level of control delay is acceptable at a signalized intersection for the same LOS.

EXHIBIT 17-22. LEVEL-OF-SERVICE CRITERIA FOR AWSC INTERSECTIONS

Level of Service	Control Delay (s/veh)
A	0–10
B	> 10–15
C	> 15–25
D	> 25–35
E	> 35–50
F	> 50

OVERVIEW OF METHODOLOGY

The methodology analyzes each intersection approach independently. The approach under study is called the subject approach. The opposing approach and the conflicting approaches create conflicts with vehicles on the subject approach.

AWSC intersections require drivers on all approaches to stop before proceeding into the intersection. While giving priority to the driver on the right is a recognized rule in

Background and concepts for AWSC intersections are given in Chapter 10

LOS thresholds for AWSC intersections differ from those for signalized intersections to reflect different driver expectations

some areas, it is not a good descriptor of actual intersection operations. What in fact happens is the development of a consensus of right-of-way that alternates between the drivers on the intersection approaches, a consensus that depends primarily on the intersection geometry and the arrival patterns at the stop line.

A two-phase pattern (Exhibit 17-23) is observed at a standard four-leg AWSC intersection (one approach lane on each leg) where drivers from opposing approaches enter the intersection at roughly the same time. Some interruption of this pattern occurs when there are conflicts between certain turning maneuvers (such as a northbound left-turning vehicle and a southbound through vehicle), but in general the north-south streams alternate right-of-way with the east-west streams. A four-phase pattern (Exhibit 17-23) emerges at multilane four-leg intersections, where the development of the right-of-way consensus is more difficult. Here drivers from each approach enter the intersection together as right-of-way passes from one approach to the next and each is served in turn.

EXHIBIT 17-23. OPERATION PATTERNS AT AWSC INTERSECTIONS

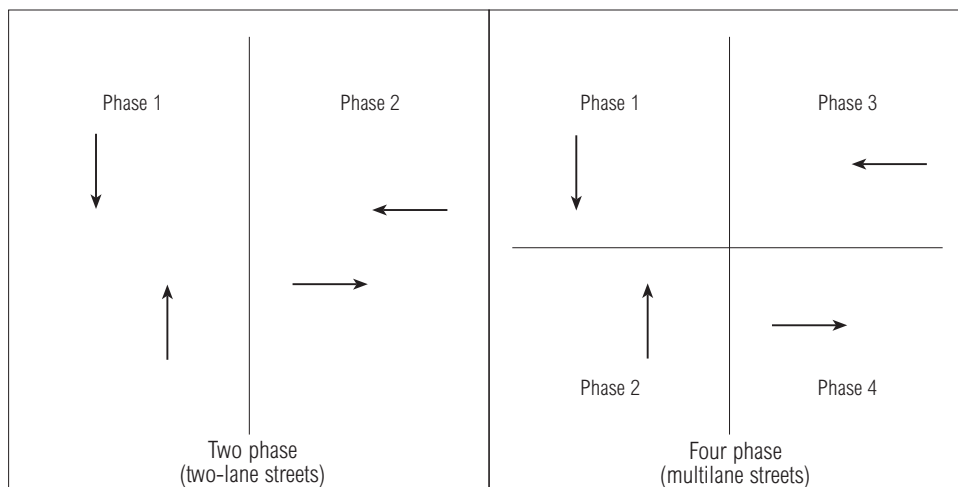

The headways of vehicles departing from the subject approach fall into one of two cases. If there are no vehicles on any of the other approaches, subject approach vehicles can enter the intersection immediately after stopping. However, if there are vehicles waiting on a conflicting approach, a vehicle from the subject approach must wait for consensus with the next conflicting vehicle. The headways between consecutively departing subject approach vehicles will be shorter for the first case than for the second. Thus, the headway for a departing subject approach vehicle depends on the degree of conflict experienced with vehicles on the other intersection approaches. The degree of conflict increases with two factors: the number of vehicles on the other approaches and the complexity of the intersection geometry.

Two other factors affect the departure headway of a subject approach vehicle: vehicle type and turning movement. The headway for a heavy vehicle will be longer than for a passenger car. Furthermore, the headway for a left-turning vehicle will be longer than for a through vehicle, which in turn will be longer than for a right-turning vehicle.

In summary:

1. AWSC intersections operate in either two-phase or four-phase patterns, based primarily on the complexity of the intersection geometry. Flows are determined by a consensus of right-of-way that alternates between the north-south and east-west streams (for a single-lane approach) or proceeds in turn to each intersection approach (for a multilane approach).
2. The headways between consecutively departing subject approach vehicles depend on the degree of conflict between these vehicles and the vehicles on the other

Two cases for departure headways

Capacity defined

intersection approaches. The degree of conflict is a function of the number of vehicles faced by the subject approach vehicle and of the number of lanes on the intersection approaches.

3. The headway of a subject approach vehicle also depends on its vehicle type and its turning maneuver.

CAPACITY MODEL

Capacity is defined as the maximum throughput on an approach given the flow rates on the other intersection approaches. The capacity model described here is an expansion of earlier work (2). The model is described for four increasingly complex cases: the intersection of two one-way streets, the intersection of two two-way streets, a generalized model for single-lane sites, and a generalized model for multilane sites.

Intersection of Two One-Way Streets

The first formulation of the model is based on the intersection of two one-way streets, each stop-controlled. Vehicles on either approach travel only straight through the intersection. See Exhibit 17-24.

EXHIBIT 17-24. AWSC CONFIGURATION - FORMULATION 1

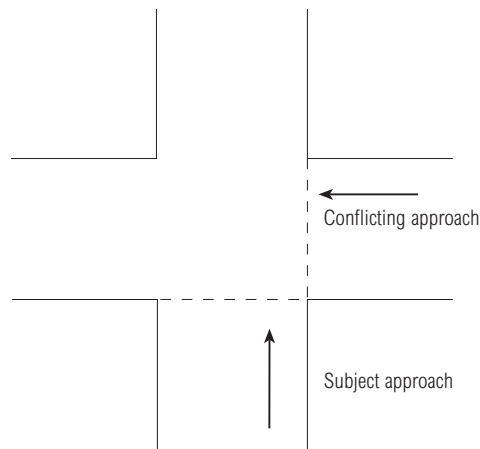

The service time for a vehicle assumes one of two values: s_1 is the service time if no vehicle is waiting on the conflicting approach and s_2 is the service time if a vehicle is waiting on the conflicting approach. The mean service time for vehicles on an approach is the expected value of this bivalued distribution. For the northbound approach, the mean service time is computed by Equation 17-42:

$$s_N = s_1 (1 - x_W) + s_2 x_W \tag{17-42}$$

where x_w is the degree of utilization of the westbound approach and is equal to the probability of finding at least one vehicle on that approach. Thus $1 - x_w$ is the probability of finding no vehicle on the westbound approach.

By symmetry, the mean service time for the westbound approach is given by Equation 17-43.

$$s_W = s_1 (1 - x_N) + s_2 x_N \tag{17-43}$$

Since the degree of utilization x is the product of the arrival rate λ and the mean service time s , the service times for each approach can be expressed in terms of the bivalued service times and the arrival rates on each approach, as in Equations 17-44 and 17-45.

$$s_N = \frac{s_1 [1 + \lambda_W (s_2 - s_1)]}{1 - \lambda_N * \lambda_W * (s_2 - s_1)^2} \tag{17-44}$$

$$s_W = \frac{s_1 [1 + \lambda_N (s_2 - s_1)]}{1 - \lambda_N * \lambda_W * (s_2 - s_1)^2} \tag{17-45}$$

Intersection of Two Two-Way Streets

The service time for a vehicle assumes one of two values, s_1 or s_2 . The mean service time for vehicles on an approach is the expected value of this bivalued distribution. A northbound vehicle will have a service time of s_1 if the eastbound and westbound approaches are empty simultaneously. The probability of this event is the product of the probability of an empty westbound approach and the probability of an empty eastbound approach. The mean service time for the northbound vehicle is computed using Equation 17-46. See Exhibit 17-25.

$$s_N = s_1(1 - x_E)(1 - x_W) + s_2[1 - (1 - x_E)(1 - x_W)] \tag{17-46}$$

Unlike Formulation 1, it is not possible to solve directly for the mean service time in terms of a combination of arrival rates and the bivalued service times. The service time on any approach is dependent on or directly coupled with the traffic intensity on the two conflicting approaches. This coupling prevents a direct solution. However, it is possible to solve for the service time on each approach in an iterative manner on the basis of a system of equations of the form shown in Equation 17-46.

EXHIBIT 17-25. AWSC CONFIGURATION - FORMULATION 2

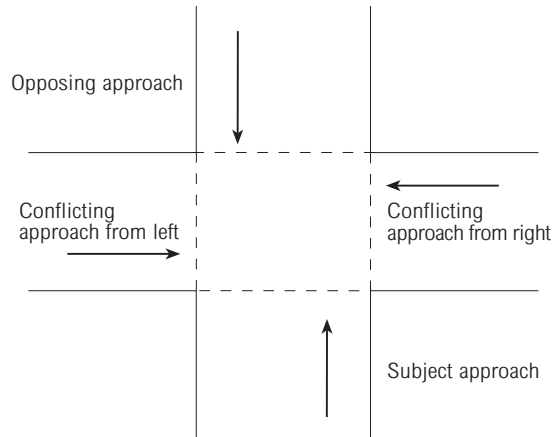

Generalized Model for Single-Lane Sites

The generalized model is based on five saturation headway values, each reflecting a different level or degree of conflict faced by the subject approach driver. Exhibit 17-26 specifies the conditions for each case and the probability of occurrence of each. The probability of occurrence is based on the degree of utilization on the opposing and conflicting approaches. The essence of the model, and its complexity, is evident when one realizes that the traffic intensity on one approach is computed from its capacity, which in turn depends on the traffic intensity on the other approaches. The interdependence of the traffic flow on all intersection approaches creates the need for iterative calculations to obtain stable estimates of departure headway and service time, and thus capacity.

Capacity is determined by an iterative procedure

EXHIBIT 17-26. PROBABILITY OF DEGREE-OF-CONFLICT CASE

Degree-of-Conflict Case	Approach				Probability of Occurrence
	Sub	Opp	Con-L	Con-R	
1	Y	N	N	N	$(1-x_o)(1-x_{CL})(1-x_{CR})$
2	Y	Y	N	N	$(x_o)(1-x_{CL})(1-x_{CR})$
3	Y	N	Y	N	$(1-x_o)(x_{CL})(1-x_{CR})$
3	Y	N	N	Y	$(1-x_o)(1-x_{CL})(x_{CR})$
4	Y	Y	N	Y	$(x_o)(1-x_{CL})(x_{CR})$
4	Y	Y	Y	N	$(x_o)(x_{CL})(1-x_{CR})$
4	Y	N	Y	Y	$(1-x_o)(x_{CL})(x_{CR})$
5	Y	Y	Y	Y	$(x_o)(x_{CL})(x_{CR})$

Note: Sub is the subject approach. Opp is the opposing approach. Con-L is the conflicting approach from the left. Con-R is the conflicting approach from the right.

From Exhibit 17-26, the probability, $P(C_i)$, for each degree-of-conflict case can be computed using Equations 17-47 through 17-51. The degrees of utilization on the opposing approach, the conflicting approach from the left, and the conflicting approach from the right are given by x_o , x_{CL} , and x_{CR} , respectively.

$$P(C_1) = (1 - x_o)(1 - x_{CL})(1 - x_{CR}) \tag{17-47}$$

$$P(C_2) = (x_o)(1 - x_{CL})(1 - x_{CR}) \tag{17-48}$$

$$P(C_3) = (1 - x_o)(x_{CL})(1 - x_{CR}) + (1 - x_o)(1 - x_{CL})(x_{CR}) \tag{17-49}$$

$$P(C_4) = (x_o)(1 - x_{CL})(x_{CR}) + (x_o)(x_{CL})(1 - x_{CR}) + (1 - x_o)(x_{CL})(x_{CR}) \tag{17-50}$$

$$P(C_5) = (x_o)(x_{CL})(x_{CR}) \tag{17-51}$$

The departure headway for an approach is the expected value of the saturation headway distribution, computed by Equation 17-52.

$$h_d = \sum_{i=1}^5 P(C_i)h_{si} \tag{17-52}$$

where $P(C_i)$ is the probability of the degree-of-conflict case C_i and h_{si} is the saturation headway for that case, given the traffic stream and geometric conditions of the intersection approach.

The service time required for the calculation of delay is computed (using Equation 17-53) on the basis of the departure headway and the move-up time.

$$t_s = h_d - m \tag{17-53}$$

where t_s is the service time, h_d is the departure headway, and m is the move-up time.

The capacity is computed as follows. The volume on the subject approach is increased incrementally until the degree of utilization on any one approach exceeds 1.0. This flow rate is the maximum possible flow or throughput on the subject approach under the conditions used as input to the analysis.

Generalized Model for Multilane Sites

Saturation headways at multilane sites will probably be longer than at single-lane sites, all other conditions being equal. This is the result of two factors. A larger intersection geometry (i.e., greater number of lanes) requires more travel time through the intersection, thus increasing the saturation headway. Additional lanes also mean an increasing degree of conflict with opposing and conflicting vehicles, again increasing driver decision time and the saturation headway.

Volume is increased until $X > 1.0$

By contrast, some movements may not as readily conflict with each other at multilane sites as at single-lane sites. For example, a northbound vehicle turning right may be able to depart simultaneously with an eastbound through movement if the two vehicles are able to occupy separate receiving lanes when departing to the east. This means that in some cases the saturation headway may be lower at multilane sites.

In the theory described earlier, it was proposed that the saturation headway is a function of the directional movement of the vehicle, the vehicle type, and the degree of conflict faced by the subject vehicle. This theory is extended here for multilane sites with respect to the concept of degree of conflict: saturation headway is affected to a large extent by the number of opposing and conflicting vehicles faced by the subject driver. For example, in Degree-of-Conflict Case 2, a subject vehicle is faced only by a vehicle on the opposing approach. At a two-lane approach intersection, there can be either one or two vehicles on the opposing approach. Each degree-of-conflict case is expanded to consider the number of vehicles present on each of the opposing and conflicting approaches. The cases are defined in Exhibits 17-27 and 17-28 for two-lane and three-lane approaches, respectively.

EXHIBIT 17-27. DEGREE-OF-CONFLICT CASES FOR TWO-LANE APPROACH INTERSECTIONS

Degree-of-Conflict Case	Approaches with Vehicles			Number of Opposing and Conflicting Vehicles
	Opposing	Conflicting Left	Conflicting Right	
1				0
2	x			1, 2
3		x		1, 2
			x	
4	x	x		2, 3, 4
	x		x	
		x	x	
5	x	x	x	3, 4, 5, 6

EXHIBIT 17-28. DEGREE-OF-CONFLICT CASES FOR THREE-LANE APPROACH INTERSECTIONS

Degree-of-Conflict Case	Approaches with Vehicles			Number of Opposing and Conflicting Vehicles
	Opposing	Conflicting Left	Conflicting Right	
1				0
2	x			1, 2, 3
3		x		1, 2, 3
			x	
4	x	x		2, 3, 4, 5, 6
	x		x	
		x	x	
5	x	x	x	3, 4, 5, 6, 7, 8, 9

For multilane sites, separate saturation headway values have been computed for the number of vehicles faced by the subject vehicle for each degree-of-conflict case. This requires a further extension of the service time model to account for the increased number of subcases.

Exhibit 17-29 gives the 27 possible combinations of the number of vehicles on each approach for each degree-of-conflict case for intersections with two lanes on each approach.

EXHIBIT 17-29. PROBABILITY OF DEGREE-OF-CONFLICT CASE—MULTILANE AWSC INTERSECTIONS (TWO-LANE APPROACH)

DOC Case/Vehicles	Number of Vehicles on Approach			
	Subject Approach	Opposing Approach	Conflicting Left Approach	Conflicting Right Approach
1/0	1	0	0	0
2/1	1	1	0	0
2/2	1	2	0	0
3/1	1	0	1	0
	1	0	0	1
3/2	1	0	2	0
	1	0	0	2
4/2	1	1	0	1
	1	1	1	0
	1	0	1	1
4/3	1	2	1	0
	1	1	2	0
	1	0	1	2
	1	0	2	1
	1	2	0	1
4/4	1	2	2	0
	1	2	0	2
	1	0	2	2
5/3	1	1	1	1
5/4	1	1	2	1
	1	2	1	1
	1	1	1	2
5/5	1	2	2	1
	1	2	1	2
	1	1	2	2
5/6	1	2	2	2

Note: DOC Case/Vehicles is the degree-of-conflict case and the number of vehicles on the opposing and conflicting approaches.

These combinations can be further subdivided if a vehicle can be on either one of the lanes on a given approach. Exhibit 17-30 gives the 64 possible combinations when alternative lane occupancies are considered; a 1 indicates that a vehicle is in the lane, and a 0 indicates that a vehicle is not in the lane. Similarly, possible combinations can be developed for intersections with three lanes on each approach.

The probability of a vehicle being at the stop line in a given lane is x , the degree of utilization. The product of the six degrees of saturation (encompassing each of the six lanes on the opposing or conflicting approaches) gives the probability of any particular combination occurring.

The departure headway of the approach is the expected value of the saturation headway distribution, given by Equation 17-54.

$$h_d = \sum_{i=1}^{64} P'(i)h_{si} \tag{17-54}$$

where i represents each combination of the five degree-of-conflict cases and h_{si} is the saturation headway for that combination.

The iterative procedure to compute the departure headways and capacities for each approach as a function of the departure headways on the other approaches is the same as described earlier. The additional subcases clearly increase the complexity of this computation, however.

EXHIBIT 17-30. PROBABILITY OF DEGREE-OF-CONFLICT CASE–MULTILANE AWSC INTERSECTIONS
(TWO-LANE APPROACHES, BY LANE)

i	DOC Case/Vehicles	Opposing Approach		Conflicting Left Approach		Conflicting Right Approach	
		L1	L2	L1	L2	L1	L2
1	1/0	0	0	0	0	0	0
2	2/1	1	0	0	0	0	0
3		0	1	0	0	0	0
4	2/2	1	1	0	0	0	0
5	3/1	0	0	0	1	0	0
6		0	0	1	0	0	0
7		0	0	0	0	1	0
8		0	0	0	0	0	1
9	3/2	0	0	1	1	0	0
10		0	0	0	0	1	1
11	4/2	0	0	0	1	0	1
12		0	0	1	0	0	1
13		0	0	1	0	1	0
14		0	0	0	1	1	0
15		0	1	0	1	0	0
16		1	0	1	0	0	0
17		0	1	0	0	1	0
18		1	0	0	1	0	0
19		0	1	1	0	0	0
20		0	1	0	0	0	1
21		1	0	0	0	1	0
22		1	0	0	0	0	1
23	4/3	0	0	0	1	1	1
24		0	0	1	1	0	1
25		0	0	1	1	1	0
26		1	0	1	1	0	0
27		1	1	1	0	0	0
28		1	1	0	0	1	0
29		1	1	0	0	0	1
30		0	1	1	1	0	0
31		1	0	0	0	1	1
32		0	0	1	0	1	1
33		1	1	0	1	0	0
34		0	1	0	0	1	1
35	4/4	1	1	0	0	1	1
36		0	0	1	1	1	1
37		1	1	1	1	0	0
38	5/3	0	1	0	1	0	1
39		1	0	0	1	1	0
40		0	1	1	0	1	0
41		0	1	0	1	1	0
42		0	1	1	0	0	1
43		1	0	1	0	0	1
44		1	0	0	1	0	1
45		1	0	1	0	1	0

Exhibit 17-30 continues on next page

EXHIBIT 17-30 (CONTINUED). PROBABILITY OF DEGREE-OF-CONFLICT CASE—MULTILANE AWSC INTERSECTIONS (TWO-LANE APPROACHES, BY LANE)

i	DOC Case/Vehicles	Opposing Approach		Conflicting Left Approach		Conflicting Right Approach	
		L1	L2	L1	L2	L1	L2
46	5/4	1	0	0	1	1	1
47		0	1	1	1	1	0
48		0	1	1	1	0	1
49		1	0	1	0	1	1
50		1	0	1	1	1	0
51		0	1	0	1	1	1
52		1	1	1	0	0	1
53		1	0	1	1	0	1
54		0	1	1	0	1	1
55		1	1	0	1	1	0
56	1	1	0	1	0	1	
57	1	1	1	1	0	1	0
58	5/5	1	0	1	1	1	1
59		1	1	0	1	1	1
60		1	1	1	0	1	1
61		0	1	1	1	1	1
62		1	1	1	1	1	0
63		1	1	1	1	0	1
64	5/6	1	1	1	1	1	1

Notes:
 DOC Case/Vehicles is the degree-of-conflict case and the number of vehicles on the opposing and conflicting approaches.
 L1 is Lane 1, and L2 is Lane 2.

CONTROL DELAY

The delay experienced by a motorist is made up of a number of factors that relate to control, geometrics, traffic, and incidents. Total delay is the difference between the travel time actually experienced and the reference travel time that would result during base conditions, in the absence of incident, control, traffic, or geometric delay. Equation 17-55 can be used to compute delay.

$$d = t_s + 900T \left[(x - 1) + \sqrt{(x - 1)^2 + \frac{h_d x}{450T}} \right] + 5 \tag{17-55}$$

where

- d = average control delay (s/veh),
- x = degree of utilization ($v h_d / 3600$),
- t_s = service time (s),
- h_d = departure headway (s), and
- T = length of analysis period (h).

III. APPLICATIONS - PART B

The methodology is applied through a set of five worksheets. They relate to input data, saturation headways, departure headways and service time, and capacity and level of service.

Exhibit 17-31 shows the analysis steps and identifies the worksheets used. The worksheets themselves are found at the end of this chapter.

Guidelines on required inputs and estimated values are given in Chapter 10

EXHIBIT 17-31. AWSC INTERSECTION METHODOLOGY

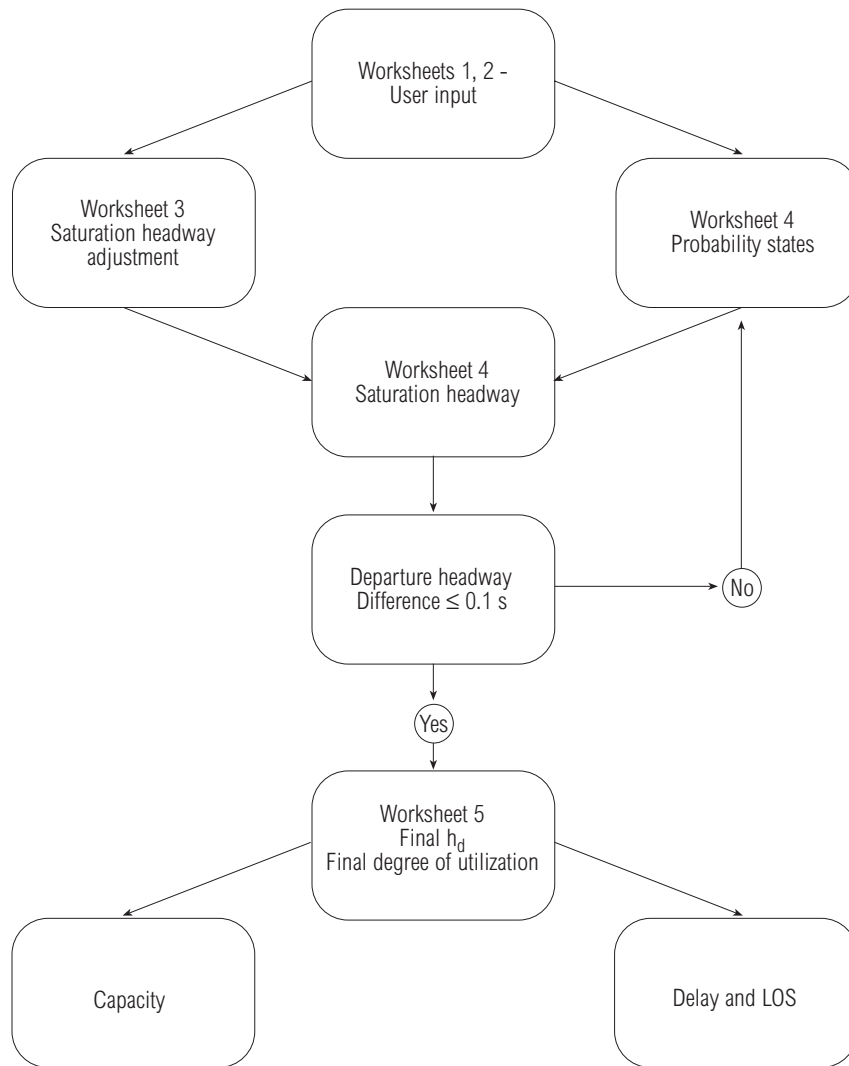

COMPUTATIONAL STEPS

Geometrics and Movements (Worksheet 1)

Worksheet 1 shows the basic features of the intersection and the movements of interest. The intersection name, the analyst’s name, the count date, and the time period are entered on this form. The north orientation arrow is also entered.

Volume Adjustments and Lane Assignments (Worksheet 2)

Movement volumes are entered into the upper tier of Worksheet 2 and adjusted for peaking by dividing volume by PHF to obtain hourly flow rates. The percentage of heavy vehicles is used to compute the headway adjustment factor in Worksheet 3. Flow rates for each lane by movement are entered into the lower tier of Worksheet 2. If more than one lane is available to a certain movement and its traffic volume distribution per lane is unknown, an equal distribution of volume among the lanes can be assumed. Exhibit 17-32 is consulted to determine the geometry group for each approach.

The geometry group is needed to look up base saturation headways and headway adjustment factors.

EXHIBIT 17-32. GEOMETRY GROUPS

Geometry Group	Intersection Configuration	Number of Lanes		
		Subject Approach	Opposing Approach	Conflicting Approaches
1	4 leg or T	1	1	1
2	4 leg or T	1	1	2
3a/4a	4 leg or T	1	2	1
3b	T	1	2	2
4b	4 leg	1	2	2
5	4 leg or T	2	1 or 2	1 or 2
5	4 leg or T	3	1 ^a	1 ^a
6	4 leg or T	3	3	3

Note:

a. If the number of lanes on the subject approach is 3 and the number of lanes on either the opposing or conflicting approaches is 1, the geometry group is 5. Otherwise, if the number of lanes on the subject approach is 3, the geometry group is 6.

Saturation Headways (Worksheet 3)

Saturation headway adjustments for left turns, right turns, and heavy vehicles are given in Exhibit 17-33. The headway adjustment for each lane is computed by Equation 17-56.

$$h_{adj} = h_{LT-adj} P_{LT} + h_{RT-adj} P_{RT} + h_{HV-adj} P_{HV} \tag{17-56}$$

where

- h_{adj} = headway adjustment,
- h_{LT-adj} = headway adjustment for left turns,
- h_{RT-adj} = headway adjustment for right turns (either -0.6 or -0.7),
- h_{HV-adj} = headway adjustment for heavy vehicles,
- P_{LT} = proportion of left-turning vehicles on the approach,
- P_{RT} = proportion of right-turning vehicles on the approach, and
- P_{HV} = proportion of heavy vehicles on the approach.

EXHIBIT 17-33. SATURATION HEADWAY ADJUSTMENTS BY GEOMETRY GROUP

Factors	Saturation Headway Adjustment (s)							
	Group 1	Group 2	Group 3a	Group 3b	Group 4a	Group 4b	Group 5	Group 6
LT	0.2	0.2	0.2	0.2	0.2	0.2	0.5	0.5
RT	-0.6	-0.6	-0.6	-0.6	-0.6	-0.6	-0.7	-0.7
HV	1.7	1.7	1.7	1.7	1.7	1.7	1.7	1.7

Departure Headway and Service Time (Worksheet 4)

Worksheet 4a

With the lane flow rates from Worksheet 2 and the initial departure headway of 3.2 s, the initial degree of utilization, x , is computed using Equation 17-57.

$$x = \frac{vh_d}{3600} \tag{17-57}$$

Calculations of h_d , with the assistance of Worksheet 4b, are repeated until the values of departure headway for each lane change by less than 0.1 s from the previous iteration. Computation of h_d for each lane and each iteration utilizes Worksheet 4b and follows the four steps described below.

Worksheet 4b

Step 1. Computation of probability states. The probability state of each combination i is determined using Equation 17-58.

Note that if it is not the final iteration and the degree of utilization exceeds 1, then the degree of utilization is reset to 1.

$$P(i) = \prod_j P(a_j) \tag{17-58}$$

where

- j = O1 (opposing approach, Lane 1), O2 (opposing approach, Lane 2), CL1 (conflicting left approach, Lane 1), CL2 (conflicting left, Lane 2), CR1 (conflicting right, Lane 1), and CR2 (conflicting right, Lane 2) for a two-lane two-way AWSC intersection;
- a_j = 1 (indicating a vehicle present) or 0 (indicating no vehicle present in the lane) (values of a_j for each lane in each combination i are listed in Exhibit 17-30); and
- $P(a_j)$ = probability of a_j , computed on the basis of Exhibit 17-34, in which V_j is the lane flow rate.

EXHIBIT 17-34. PROBABILITY OF a_j

a_j	V_j	$P(a_j)$
1	0	0
0	0	1
1	> 0	x_j^a
0	> 0	$1 - x_j^a$

Note:

a. x is the degree of utilization defined in Equation 17-57.

Step 2. Probability adjustment factor. The probability adjustment is computed, using Equations 17-59 through 17-63, to account for the serial correlation in the previous probability computation. First, the probability of each degree-of-conflict case must be determined.

$$P(C_1) = P(1) \tag{17-59}$$

$$P(C_2) = \sum_{i=2}^4 P(i) \tag{17-60}$$

$$P(C_3) = \sum_{i=5}^{10} P(i) \tag{17-61}$$

$$P(C_4) = \sum_{i=11}^{37} P(i) \tag{17-62}$$

$$P(C_5) = \sum_{i=38}^{64} P(i) \tag{17-63}$$

The probability adjustment factors are then computed using Equations 17-64 through 17-68.

$$AdjP(1) = \alpha[P(C_2) + 2P(C_3) + 3P(C_4) + 4P(C_5)]/1 \tag{17-64}$$

$$AdjP(2) \text{ through } AdjP(4) = \alpha[P(C_3) + 2P(C_4) + 3P(C_5) - P(C_2)]/3 \tag{17-65}$$

$$AdjP(5) \text{ through } AdjP(10) = \alpha[P(C_4) + 2P(C_5) - 3P(C_3)]/6 \tag{17-66}$$

$$AdjP(11) \text{ through } AdjP(37) = \alpha[P(C_5) - 6P(C_4)]/27 \tag{17-67}$$

$$AdjP(38) \text{ through } AdjP(64) = -\alpha[10P(C_5)]/27 \tag{17-68}$$

where α equals 0.01 (or 0.00 if correlation among saturation headways is not taken into account).

The adjusted probability $P'(i)$ for each combination is simply the sum of $P(i)$ and $AdjP(i)$, as given by Equation 17-69.

$$P'(i) = P(i) + AdjP(i) \tag{17-69}$$

Step 3. Saturation headway. The saturation headway h_{si} is the sum of the base saturation headway as given in Exhibit 17-35 and the saturation headway adjustment factor from Worksheet 3. Note that all values in the h_{adj} column should be the same because one Worksheet 4b is used for each lane.

Step 4. Departure headway. Departure headway is computed using Equation 17-54.

EXHIBIT 17-35. SATURATION HEADWAY VALUES BY CASE AND GEOMETRY GROUP

Case	No. of Veh	Base Saturation Headway (s)							
		Group 1	Group 2	Group 3a	Group 3b	Group 4a	Group 4b	Group 5	Group 6
1	0	3.9	3.9	4.0	4.3	4.0	4.5	4.5	4.5
2	1	4.7	4.7	4.8	5.1	4.8	5.3	5.0	6.0
	2							6.2	6.8
	≥ 3							7.4	7.4
3	1	5.8	5.8	5.9	6.2	5.9	6.4	6.4	6.6
	2							7.2	7.3
	≥ 3							7.8	7.8
4	2	7.0	7.0	7.1	7.4	7.1	7.6	7.6	8.1
	3							7.8	8.7
	4							9.0	9.6
	≥ 5							12.3	12.3
5	3	9.6	9.6	9.7	10.0	9.7	10.2	9.7	10.0
	4							9.7	11.1
	5							10.0	11.4
	≥ 6							11.5	13.3

Capacity and Level of Service (Worksheet 5)

Worksheet 5 is used to determine delay and LOS. Control delay per vehicle is computed for each lane and each approach using Equation 17-55. The approach delay is the weighted average of the delay on each lane, and the intersection delay is the weighted average of the delay on each of the approaches. The LOS for each approach and for the intersection is determined using Exhibit 17-22 and the computed values of control delay.

The capacity of each approach is computed under the assumption that the flows on the opposing and conflicting approaches are constant. The given flow rate on the subject lane is increased and the departure headways are computed for each approach using Worksheets 4a and 4b until the degree of utilization for the subject lane reaches 1. When this occurs, the final value of the subject approach flow rate is the maximum possible throughput or capacity of this lane. Note that the move-up time for the lane is either 2.0 s (for Geometry Groups 1 through 4) or 2.3 s (for Geometry Groups 5 and 6).

PLANNING AND DESIGN APPLICATIONS

The operational analysis method described earlier in this chapter provides a detailed procedure for evaluating the performance of an AWSC intersection. To estimate LOS for a future time horizon, a planning analysis based on the operational method is used. The planning method uses all the geometric and traffic flow data required for an operational analysis, and the computations are identical. However, many input variables are estimated (or defaults used) when planning applications are performed.

The operational analysis described earlier in this chapter is not normally used for design purposes. However, through iteration the analyst can use a given set of traffic flow data and determine the number of lanes that would be required to produce a given level of service.

Capacity is estimated for a stated set of opposing and conflicting volumes

PART C. ROUNDABOUTS

I. INTRODUCTION - PART C

In this section of Chapter 17, procedures for the analysis of roundabouts are presented. Terminology applying to the unique characteristics of roundabout capacity is introduced. For ease of reference, the following terms are defined:

- c_a = approach capacity,
- v_a = approach flow rate, and
- v_c = circulating flow rate.

Roundabouts have been used successfully in cities throughout the world and are being used increasingly in the United States. Although extensive literature on roundabout modeling has evolved worldwide, there is limited experience with their application in North America. Accordingly, a comprehensive methodology for all situations cannot be offered. The procedure described in this section makes the best use of the limited field data collected at roundabouts in the United States to modify the operating parameters of established performance analysis techniques. Whereas it should be used with care until additional research is conducted, the procedure does provide the U.S. practitioner with basic guidelines concerning the capacity of a roundabout.

Intersection analysis models generally fall into two categories. Empirical models rely on field data to develop relationships between geometric design features and performance measures such as capacity and delay. Analytical models are based on the concept of gap acceptance theory. The choice of an analysis approach depends on the calibration data available. Empirical models are generally better but require a number of congested roundabouts for calibration. Gap acceptance models, however, can be developed from uncongested roundabouts (1). A gap acceptance approach for analyzing roundabouts is presented here.

II. METHODOLOGY - PART C

OVERVIEW OF METHODOLOGY

The capacity at a roundabout can be estimated using gap acceptance techniques with the basic parameters of critical gap and follow-up time.

It has generally been assumed that the performance of each leg of a roundabout can be analyzed independently of the other legs, and consequently most techniques tend to use information on only one leg (2, 3). Exhibit 17-36 shows the traffic flows being considered.

It has also been shown (4) that the origin-destination paths at roundabouts affect the capacity. This is reasonable, as the increased number of drivers who use a smaller radius when making a left turn will travel farther around the roundabout, will travel slower, and may have a longer intraplatoon headway (or lower saturation flow). The longer intraplatoon headway will reduce the opportunities for drivers to enter the roundabout, and the capacity will be reduced.

In other circumstances, drivers at roundabouts in other countries have been found to accept small gaps. This behavior has now been found to cause the following circulating drivers to slow and the following headways to be reduced. This affects the predicted capacity if only the circulating headways are used. Good estimates of capacity have been found for single-lane roundabouts if the circulating flows are assumed to be random. This is the same assumption that has been used in the analysis of TWSC intersections.

The roundabout methodology is based on gap acceptance

Headways are assumed to be randomly distributed

EXHIBIT 17-36. ANALYSIS ON ONE ROUNDABOUT LEG

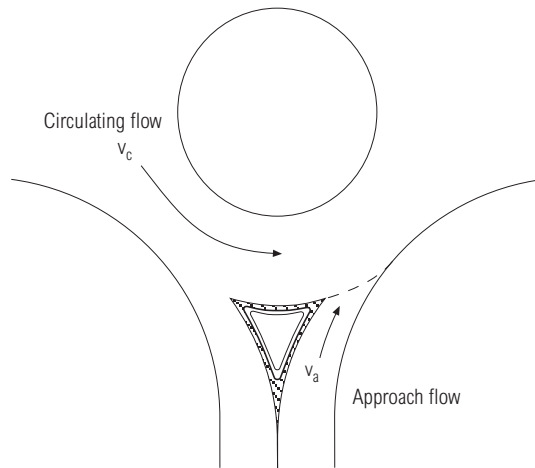

Because roundabouts involve drivers making a right turn onto the roundabout, the gap acceptance characteristics of drivers are expected to be the same as or similar to those of drivers making right turns at TWSC intersections. The concepts described in the section dealing with TWSC intersections are generally applicable to single-lane roundabouts. There are more traffic interactions at multilane roundabouts that influence driver behavior and make the TWSC technique inapplicable. More details on roundabout experience in the United States will be needed before a complete analysis procedure can be presented in the *Highway Capacity Manual*.

CAPACITY

The estimate of the capacity of a roundabout approach is given by Equation 17-70.

$$c_a = \frac{v_c e^{-v_c t_c / 3600}}{1 - e^{-v_c t_f / 3600}} \tag{17-70}$$

where

- c_a = approach capacity (veh/h),
- v_c = conflicting circulating traffic (veh/h),
- t_c = critical gap (s), and
- t_f = follow-up time (s).

Limited studies of roundabouts in the United States (5), as well as comparisons with operations in countries with experience in the design and operation of roundabouts (6), indicate that a range of values of critical gap and follow-up time should provide the analyst with a reasonable estimate of the approximate capacity of a planned roundabout. The recommended ranges are given in Exhibit 17-37. The relationship between approach capacity and circulating flow for these upper- and lower-bound values of critical gap and follow-up time is shown in Exhibit 17-38.

EXHIBIT 17-37. CRITICAL GAP AND FOLLOW-UP TIMES FOR ROUNDABOUTS

	Critical Gap (s)	Follow-Up Time (s)
Upper bound	4.1	2.6
Lower bound	4.6	3.1

The capacity model is for single-lane operation

EXHIBIT 17-38. ROUNDABOUT APPROACH CAPACITY

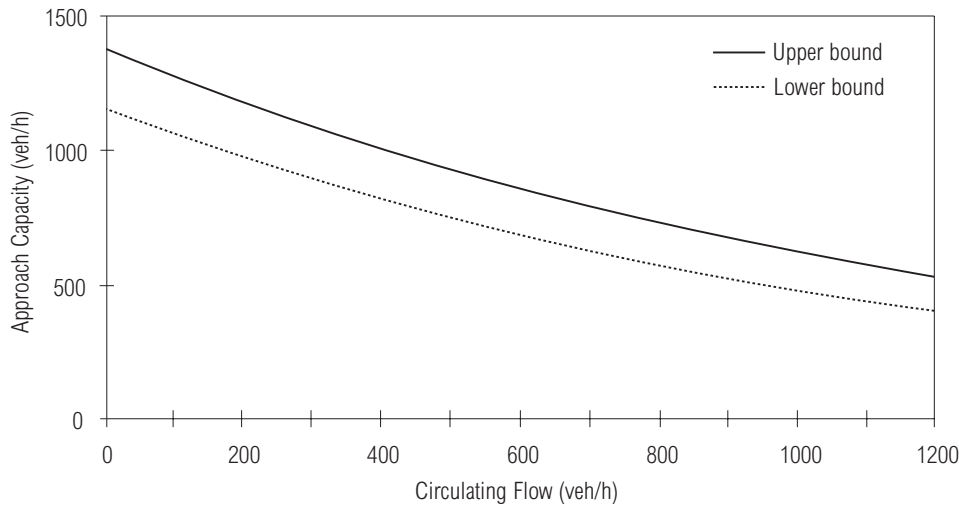

The conflicting flows are calculated by evaluating the 15-min volumes of vehicles passing in front of the entering vehicles. In other countries, the effect of vehicles exiting into the road where drivers are entering has been found to be of the second order. At most well-designed roundabouts the exiting traffic can be ignored.

In practice, it is necessary to convert the intersection turning movements into the circulating flows—the volumes v_1 to v_{12} as shown in Exhibit 17-39. For example, the circulating traffic for the entry by Streams 7, 8, and 9 is Streams 1, 2, and 10. Consequently, v_c would be equal to $v_1 + v_2 + v_{10}$. Roundabouts can often be used to facilitate U-turns, and the flow of U-turns should be included in the volumes.

This methodology is not applicable if a circulating volume is greater than 1,200 veh/h

EXHIBIT 17-39. FLOW STREAM DEFINITIONS

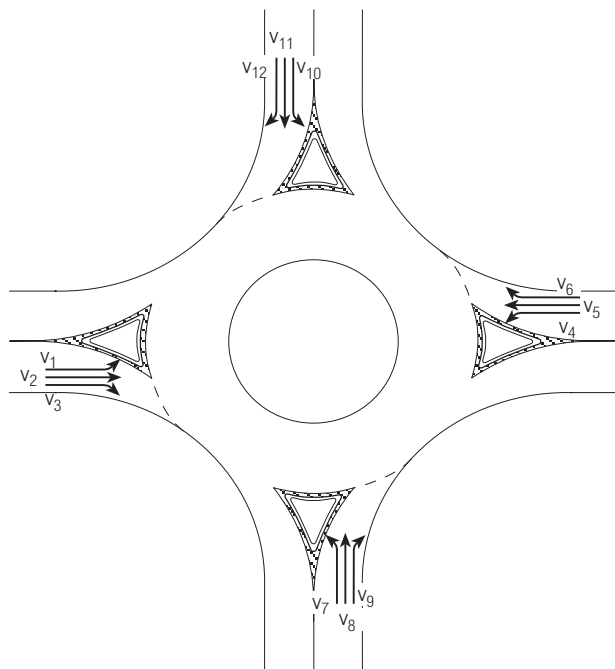

The above methodology applies to single-lane roundabouts. Experience with multiple-lane roundabouts in the United States is insufficient to support an analysis procedure. Experience in other countries indicates that capacity may be increased by increasing the number of lanes on the approaches and on the circulating roadway, but the effect is less than that of a full additional lane. In other words, doubling the number of lanes does not double the capacity. In addition, the performance of multiple-lane roundabouts is affected to a greater extent by site geometrics and driver characteristics. It is widely recognized that each of the approach lanes is likely to have substantially different gap acceptance characteristics.

If capacity values are required for multiple-lane roundabouts, a comprehensive roundabout analysis model should be used in lieu of the procedures presented here. Caution is necessary in the interpretation of the results produced by these models because their internal assumptions and parameters have not been well validated in the United States.

III. APPLICATIONS - PART C

The steps required to perform a roundabout analysis are identified below. A worksheet is provided to assist the analyst in completing the computations. The worksheet is applicable only to single-lane roundabouts with circulating flows less than 1,200 veh/h. The steps are as follows:

1. Define the existing geometry and traffic conditions for the roundabout under study. For each leg, volume data are entered for each approach. The approach flow is computed and entered in the next section of the worksheet.
2. Determine the conflicting (circulating) traffic at each leg of the roundabout. For each leg, the approach and the circulating traffic are computed and entered in the next table. If the circulating flow exceeds 1,200 veh/h, this procedure should not be used, unless field data have been collected for the critical gap and follow-up time.
3. Determine the capacity of the entry lanes using Equation 17-70.
4. Assess the general performance of the roundabout on the basis of the v/c ratio.

Guidelines for input and estimated values are given in Chapter 10

PART D. EXAMPLE PROBLEMS

Problem No.	Description	Application
1	TWSC Unsignalized Intersection	Operational LOS
2	TWSC Unsignalized Intersection	Operational LOS
3	TWSC Unsignalized Intersection	Operational LOS
4	AWSC Unsignalized Intersection	Operational LOS
5	AWSC Unsignalized Intersection	Operational LOS
6	Roundabout	Capacity and v/c ratio

<p>9. Control delay and LOS (use Equation 17-38 and Exhibit 17-2).</p>	<p>Worksheet 10</p> $d = \frac{3,600}{C_{m,x}} + 900T[\dots] + 5$ $d_{NB} = \frac{3,600}{523} + 900(0.25)[\dots] + 5 = 14.9 \text{ s}$ <p>LOS B</p>
<p>10. Skip Worksheet 11.</p>	<p>No Rank 1 vehicle delay</p>

Example Problem 1

TWSC - UNSIGNALIZED INTERSECTIONS WORKSHEET

Worksheet 1

General Information		Site Information	
Analyst	<u>KMN</u>	Intersection	<u>Jones/Market</u>
Agency or Company	<u>CEI</u>	Jurisdiction	<u>Latah County</u>
Date Performed	<u>5/17/99</u>	Analysis Year	<u>1999</u>
Analysis Time Period	<u>AM Peak</u>		

Geometrics and Movements

Length of study period = 0.25 h

Worksheet 2

Vehicle Volumes and Adjustments

Movement	Vehicle Volumes and Adjustments											
	1	2	3	4	5	6	7	8	9	10	11	12
Volume (veh/h)		250	40	150	300		40		120			
Peak-hour factor, PHF		1.00	1.00	1.00	1.00		1.00		1.00			
Hourly flow rate (veh/h)		250	40	150	300		40		120			
Proportion of heavy vehicles, P _{HV}		0.10	0.10	0.10	0.10		0.10		0.10			

Pedestrian Volumes and Adjustments

Movement	13	14	15	16
Flow, V _x (ped/h)	0	0	0	0
Lane width, w (ft)				
Walking speed, ¹ S _p (ft/s)				
Percent blockage, f _p (Equation 17-11)				

1. Default walking speed = 4.0 ft/s

Example Problem 1

TWSC - UNSIGNALIZED INTERSECTIONS WORKSHEET								
Worksheet 3								
General Information								
Project Description <u>Example Problem 1</u>								
Lane Designation								
Movements	Lane 1	Lane 2	Lane 3	Grade, G	Right Turn Channelized?			
1, 2, 3	2, 3			0	N			
4, 5, 6	4	5		0	N			
7, 8, 9	7, 8			0	N			
10, 11, 12								
Flared Minor-Street Approach								
Movement 9	<input type="checkbox"/> Yes	<input checked="" type="checkbox"/> No	Storage space, n	_____				
	(number of vehicles)							
Movement 12	<input type="checkbox"/> Yes	<input checked="" type="checkbox"/> No	Storage space, n	_____				
	(number of vehicles)							
Median Storage*								
* Includes raised or striped median (RM), or two-way left-turn lane (TWLTL)								
Type								
Movements 7 and 8	<input type="checkbox"/> Yes	_____	<input checked="" type="checkbox"/> No	Storage space, m	_____			
	(number of vehicles)							
Movements 10 and 11	<input type="checkbox"/> Yes	_____	<input checked="" type="checkbox"/> No	Storage space, m	_____			
	(number of vehicles)							
Upstream Signals								
	Movements	Distance to Signal, D (ft)	Prog Speed, S _{prog} (mi/h)	Cycle Length, C (s)	Green Time, g _{eff} (s)	Arrival Type	Saturation Flow Rate, s (veh/h)	Progressed Flow, V _{prog} (veh/h)
S ₂	protected LT					3		
	TH							
S ₅	protected LT					3		
	TH							
Computing Delay to Major-Street Vehicles								
Data for Computing Effect of Delay to Major-Street Vehicles				S ₂ Approach		S ₅ Approach		
Shared-lane volume, major-street through vehicles, v ₁₁ , blocked by LT								
Shared-lane volume, major-street right-turn vehicles, v ₁₂ , blocked by LT								
Saturation flow rate, major-street through vehicles, s ₁₁								
Saturation flow rate, major-street right-turn vehicles, s ₁₂								
Number of major-street through lanes								
Length of study period, T (h)								

TWSC - UNSIGNALIZED INTERSECTIONS WORKSHEET									
Worksheet 4									
General Information									
Project Description <u>Example Problem 1</u>									
Critical Gap and Follow-Up Time									
$t_c = t_{c,base} + t_{c,HV} P_{HV} + t_{c,G} G - t_{c,T} - t_{3,LT}$									
	Major LT			Minor RT		Minor TH		Minor LT	
Movement	1	4	9	12	8	11	7	10	
$t_{c,base}$ (Exhibit 17-5)		4.1	6.2				7.1		
$t_{c,HV}$		1.0	1.0				1.0		
P_{HV} (from Worksheet 2)		0.10	0.10				0.10		
$t_{c,G}$	-	-	0.1	0.1	0.2	0.2	0.2	0.2	
G (from Worksheet 3)		0	0				0		
$t_{3,LT}$		0.0	0.0				0.7		
$t_{c,T}$	single stage	0.0	0.0				0.0		
	two stage								
t_c (Equation 17-1)	single stage	4.200	6.300				6.500		
	two stage								
$t_f = t_{f,base} + t_{f,HV} P_{HV}$									
	Major LT			Minor RT		Minor TH		Minor LT	
Movement	1	4	9	12	8	11	7	10	
$t_{f,base}$ (Exhibit 17-5)		2.2	3.3				3.5		
$t_{f,HV}$		0.9	0.9				0.9		
P_{HV} (from Worksheet 2)		0.10	0.10				0.10		
t_f (Equation 17-2)		2.290	3.390				3.590		
Worksheet 5a									
Time to Clear Standing Queue (Computation 1)									
	Movement 2				Movement 5				
	$v_{T,prog}$		$v_{L,prot}$		$v_{T,prog}$		$v_{L,prot}$		
Effective green, g_{eff} (s)									
Cycle length, C (s)									
Saturation flow rate, s (veh/h)									
Arrival type			3				3		
v_{prog} (veh/h)									
R_p (from Chapter 16)			1.00				1.00		
Proportion of vehicles arriving on green, P (Equation 17-17)									
g_{q1} (Equation 17-18)									
g_{q2} (Equation 17-19)									
g_q (Equation 17-20)									

Example Problem 1

TWSC - UNSIGNALIZED INTERSECTIONS WORKSHEET		
Worksheet 6		
General Information		
Project Description <u>Example Problem 1</u>		
Impedance and Capacity Calculation		
Step 1: RT from Minor Street	v_g	v_{12}
Conflicting flows (Exhibit 17-4)	$v_{c,9} = 270$	$v_{c,12} =$
Potential capacity (Equation 17-3 or 17-29)	$c_{p,9} = 750$	$c_{p,12} =$
Ped impedance factor (Equation 17-12)	$p_{p,9} = 1.000$	$p_{p,12} =$
Movement capacity (Equation 17-4)	$c_{m,9} = c_{p,9} p_{p,9} = 750$	$c_{m,12} = c_{p,12} p_{p,12} =$
Prob of queue-free state (Equation 17-5)	$\rho_{0,9} = 0.840$	$\rho_{0,12} = 1.000$
Step 2: LT from Major Street	v_4	v_1
Conflicting flows (Exhibit 17-4)	$v_{c,4} = 290$	$v_{c,1} =$
Potential capacity (Equation 17-3 or 17-29)	$c_{p,4} = 1227$	$c_{p,1} =$
Ped impedance factor (Equation 17-12)	$p_{p,4} = 1.000$	$p_{p,1} =$
Movement capacity (Equation 17-4)	$c_{m,4} = c_{p,4} p_{p,4} = 1227$	$c_{m,1} = c_{p,1} p_{p,1} =$
Prob of queue-free state (Equation 17-5)	$\rho_{0,4} = 0.878$	$\rho_{0,1} = 1.000$
Major left shared lane prob of queue-free state (Equation 17-16)	$\rho_{0,4}^* =$	$\rho_{0,1}^* =$
Step 3: TH from Minor Street (4-leg intersections only)	v_8	v_{11}
Conflicting flows (Exhibit 17-4)	$v_{c,8} =$	$v_{c,11} =$
Potential capacity (Equation 17-3 or 17-29)	$c_{p,8} =$	$c_{p,11} =$
Ped impedance factor (Equation 17-12)	$p_{p,8} =$	$p_{p,11} =$
Capacity adjustment factor due to impeding movement (shared lane use p^*) (Equation 17-13)	$f_8 = \rho_{0,4} \rho_{0,1} p_{p,8} =$	$f_{11} = \rho_{0,4} \rho_{0,1} p_{p,11} =$
Movement capacity (Equation 17-7)	$c_{m,8} = c_{p,8} f_8 =$	$c_{m,11} = c_{p,11} f_{11} =$
Prob of queue-free state	$\rho_{0,8} =$	$\rho_{0,11} =$
Step 4: LT from Minor Street (4-leg intersections only)	v_7	v_{10}
Conflicting flows (Exhibit 17-4)	$v_{c,7} =$	$v_{c,10} =$
Potential capacity (Equation 17-3 or 17-29)	$c_{p,7} =$	$c_{p,10} =$
Ped impedance factor (Equation 17-12)	$p_{p,7} =$	$p_{p,10} =$
Major left, minor through impedance factor	$p_7^* = \rho_{0,11} f_{11} =$	$p_{10}^* = \rho_{0,8} f_8 =$
Major left, minor through adjusted impedance factor (Equation 17-8)	$p_7' =$	$p_{10}' =$
Capacity adjustment factor due to impeding movements (Equation 17-14)	$f_7 = p_7' \rho_{0,12} p_{p,7} =$	$f_{10} = p_{10}' \rho_{0,9} p_{p,10} =$
Movement capacity (Equation 17-10)	$c_{m,7} = f_7 c_{p,7} =$	$c_{m,10} = f_{10} c_{p,10} =$
Step 5: LT from Minor Street (T-intersections only)	v_7	v_{10}
Conflicting flows (Exhibit 17-4)	$v_{c,7} = 870$	$v_{c,10} =$
Potential capacity (Equation 17-3 or 17-29)	$c_{p,7} = 312$	$c_{p,10} =$
Ped impedance factor (Equation 17-12)	$p_{p,7} = 1.000$	$p_{p,10} =$
Capacity adjustment factor due to impeding movement (shared lane use p^*) (Equation 17-13)	$f_7 = \rho_{0,4} \rho_{0,1} p_{p,7} = 0.878$	$f_{10} = \rho_{0,4} \rho_{0,1} p_{p,10} =$
Movement capacity (Equation 17-7)	$c_{m,7} = c_{p,7} f_7 = 274$	$c_{m,10} = c_{p,10} f_{10} =$
Notes		
1. For 4-leg intersections use Steps 1, 2, 3, and 4.		
2. For T-intersections use Steps 1, 2, and 5.		

TWSC - UNSIGNALIZED INTERSECTIONS WORKSHEET							
Worksheet 8							
General Information							
Project Description <u>Example Problem 1</u>							
Shared-Lane Capacity							
$c_{SH} = \frac{\sum v_y}{y} \quad \text{(Equation 17-15)}$ $c_{SH} = \frac{\sum v_y}{y \left(\frac{v_y}{c_{m,y}} \right)}$							
	v (veh/h)			c _m (veh/h)			c _{SH} (veh/h)
Lane	Movement 7	Movement 8	Movement 9	Movement 7	Movement 8	Movement 9	
1	40		120	274		750	523
2							
3							
	Movement 10	Movement 11	Movement 12	Movement 10	Movement 11	Movement 12	
1							
2							
3							
Worksheet 9							
Effect of Flared Minor-Street Approaches							
	Lane _____			Lane _____			
	Movement 7	Movement 8	Movement 9	Movement 10	Movement 11	Movement 12	
c _{sep} (from Worksheet 6 or 7)							
volume (from Worksheet 2)							
delay (Equation 17-38)							
Q _{sep} (Equation 17-34)							
Q _{sep} + 1							
round (Q _{sep} + 1)							
n _{max} (Equation 17-35)							
c _{SH}							
c _{sep}							
n							
c _{act} (Equation 17-36)							

Example Problem 1

TWSC - UNSIGNALIZED INTERSECTIONS WORKSHEET

Worksheet 10

General Information

Project Description Example Problem 1

Control Delay, Queue Length, Level of Service

Lane	v (veh/h)	c _m (veh/h)	v/c	Queue Length (Equation 17-37)	Control Delay (Equation 17-38)	LOS (Exhibit 17-2)	Delay and LOS
1 (X)(X)(X)	160	523	0.306	< 2	14.9	B	14.9 B
2 (7)(8)(9)							
3 (7)(8)(9)							
1 (10)(11)(12)							
2 (10)(11)(12)							
3 (10)(11)(12)							

Movement	v (veh/h)	c _m (veh/h)	v/c	Queue Length (Equation 17-37)	Control Delay (Equation 17-38)	LOS (Exhibit 17-2)
1						
4	150	1227	0.12	< 1	8.3	A

Worksheet 11

Delay to Rank 1 Vehicles

	S ₂ Approach	S ₅ Approach
p _{0,j} (Equation 17-5)	p _{0,1} =	p _{0,4} =
v ₁₁ , volume for Stream 2 or 5		
v ₁₂ , volume for Stream 3 or 6		
s ₁₁ , saturation flow rate for Stream 2 or 5		
s ₁₂ , saturation flow rate for Stream 3 or 6		
p _{0,j} [*] (Equation 17-16)	p _{0,1} [*] =	p _{0,4} [*] =
d _{major left} , delay for Stream 1 or 4		
N, number of major-street through lanes		
d _{Rank 1} , delay for Stream 2 or 5 (Equation 17-39)		

EXAMPLE PROBLEM 2

The Intersection A TWSC intersection with upstream signals. The major street is Walnut St. (EB/WB) and the minor street is Elm St. (NB/SB).

The Question What are the delay and level of service of the minor-street approaches?

The Facts

- √ Four-lane major street, √ 10 percent HV,
- √ Two-lane minor street, √ Upstream signals in both major-street directions, and
- √ Level grade, √ No pedestrians.

Outline to Solution The steps below show the northbound approach calculations only. Calculations for other approaches are shown on the worksheets.

Steps

1. Data input.	Worksheets 1 and 2
2. Site characteristics.	Worksheet 3 - lane designation, grades, right-turn channelization, and upstream signals
3. t_c and t_f (s) (use Equations 17-1 and 17-2 and Exhibit 17-5).	$t_{c,x} = t_{c,base} + t_{c,HV} P_{HV} + t_{c,G} G - t_{c,T} - t_{3,LT}$ $t_{c,1} = 4.1 + 2.0(0.10) + 0 - 0 - 0 = 4.300 \text{ s}$ $t_{f,x} = t_{f,base} + t_{f,HV} P_{HV}$ $t_{f,1} = 2.2 + 1.0(0.10) = 2.300 \text{ s}$
4. Effect of upstream signals Proportion of vehicles arriving during green, P (use Equation 17-17). Discharge time (use Equations 17-18, 17-19, and 17-20). Maximum platoon flow rate, $v_{c,max}$ (use Equation 17-21). Minimum platoon flow rate, $v_{c,min}$. Duration of blocked period, $t_{p,i}$ (use Equation 17-22). Proportion of time blocked (use Equation 17-23).	Worksheets 5a through 5e $P = R_p \frac{g_{eff}}{C}$ $P = 0.33 \frac{30}{80} = 0.124$ For Movement 2 $g_q = g_{q1} + g_{q2}$ $g_{q1} = \frac{v_{prog} C (1-P)}{s} = \frac{250(80)(1-0.124)}{3,600} = 4.867$ $g_{q2} = \frac{v_{prog} C P g_{q1}}{s g_{eff} - v_{prog} C P} = \frac{250(80)(0.124)(4.867)}{3,600(30) - 250(80)(0.124)} = 0.114$ $g_q = 4.867 + 0.114 = 4.981$ $v_{c,max} = sf[1 - (1-F)^{g_q}]$ $v_{c,max} = 3,600(0.751)[1 - (1-0.253)^{4.981}] = 2,071 \text{ veh/h}$ $v_{c,min} = 1,000(2) = 2,000$ $t_{p,i} = g_q - \frac{\ln \left[\left(1 - \frac{v_{c,min}}{sf} \right) \left(\frac{v_{c,max} - v_{prog} R_p f}{v_{c,min} - v_{prog} R_p f} \right) \right]}{\ln(1-F)}$ $t_{p,2} = 4.981 - \frac{\ln \left[\left(1 - \frac{2,000}{3,600(0.751)} \right) \left(\frac{2,071 - 250(0.33)(0.751)}{2,000 - 250(0.33)(0.751)} \right) \right]}{\ln(1-0.253)} = 0.489$ $p_i = \frac{t_{p,T} + t_{p,L}}{C}$ $p_2 = \frac{0.489}{80} = 0.006$

<p>4. (continued) Dominant and subordinate platoons (use Equations 17-24 and 17-25). Conflicting flow during unblocked period (use Equation 17-28). Capacity during unblocked period, $c_{r,x}$ (use Equation 17-3). Potential capacity, $c_{plat,x}$, accounting for platooning (use Equation 17-29).</p>	$p_{dom} = \max(p_2, p_5)$ $p_{subo} = \min(p_2, p_5)$ $p_{dom} = P_2 = 0.006$ $p_{subo} = P_5 = 0.000$ $v_{c,u,x} = \frac{v_{c,x} - s(1 - p_x)}{p_x}$ $v_{c,u,1} = \frac{400 - 3,600(1 - 1.000)}{1.000} = 400 \text{ veh/h}$ $c_{r,x} = v_{c,u,x} \frac{e^{-v_{c,u,x}t_{c,x}/3,600}}{1 - e^{-v_{c,u,x}t_{c,x}/3,600}}$ $c_{r,1} = 400 \frac{e^{-400(4.300)/3,600}}{1 - e^{-400(2.300)/3,600}} = 1,100 \text{ veh/h}$ $c_{plat,x} = p_x c_{r,x}$ $c_{plat,1} = 1.000(1,100) = 1,100 \text{ veh/h}$
<p>5. Movement capacity, $c_{m,x}$, accounting for impedance (use Equation 17-4, 17-7, or 17-10).</p>	$c_{m,x} = c_{plat,x} f_x$ $c_{m,1} = 1,100(1.000) = 1,100 \text{ veh/h}$
<p>6. Skip Worksheets 7a and 7b.</p>	<p>No two-stage gap acceptance</p>
<p>7. Shared-lane capacity Worksheet 8 (use Equation 17-15).</p>	$c_{SH} = \frac{\sum v_y}{\sum \frac{v_y}{c_{m,y}}}$ $c_{SH(NB)} = \frac{44 + 132 + 55}{\frac{44}{202} + \frac{132}{254} + \frac{55}{867}} = 288 \text{ veh/h}$
<p>8. Skip Worksheet 9.</p>	<p>No flared minor-street approaches</p>
<p>9. Control delay and LOS (use Equation 17-38 and Exhibit 17-2).</p>	$d = \frac{3,600}{c_{m,x}} + 900T[\dots] + 5$ $d_{NB} = \frac{3,600}{288} + 900(0.25)[\dots] + 5 = 53.5 \text{ s, LOS F}$
<p>10. Skip Worksheet 11.</p>	<p>No Rank 1 vehicle delay</p>

TWSC - UNSIGNALIZED INTERSECTIONS WORKSHEET

Worksheet 1

General Information	Site Information
Analyst <u>JME</u>	Intersection <u>Walnut/Elm</u>
Agency or Company <u>CEI</u>	Jurisdiction <u>Latah County</u>
Date Performed <u>5/7/99</u>	Analysis Year <u>1999</u>
Analysis Time Period <u>AM Peak</u>	

Geometrics and Movements

Length of study period = 0.25 h

Worksheet 2

Vehicle Volumes and Adjustments

Movement	Vehicle Volumes and Adjustments											
	1	2	3	4	5	6	7	8	9	10	11	12
Volume (veh/h)	33	250	50	66	300	100	44	132	55	11	110	28
Peak-hour factor, PHF	1.000	1.000	1.000	1.000	1.000	1.000	1.000	1.000	1.000	1.000	1.000	1.000
Hourly flow rate (veh/h)	33	250	50	66	300	100	44	132	55	11	110	28
Proportion of heavy vehicles, P _{HV}	0.10	0.10	0.10	0.10	0.10	0.10	0.10	0.10	0.10	0.10	0.10	0.10

Pedestrian Volumes and Adjustments

Movement	13	14	15	16
Flow, V _x (ped/h)	0	0	0	0
Lane width, w (ft)				
Walking speed, ¹ S _p (ft/s)				
Percent blockage, f _p (Equation 17-11)				

1. Default walking speed = 4.0 ft/s

Example Problem 2

TWSC - UNSIGNALIZED INTERSECTIONS WORKSHEET								
Worksheet 3								
General Information								
Project Description <u>Example Problem 2</u>								
Lane Designation								
Movements	Lane 1	Lane 2	Lane 3	Grade, G	Right Turn Channelized?			
1, 2, 3	1	2	2, 3	0	N			
4, 5, 6	4	5	5, 6	0	N			
7, 8, 9	7, 8, 9			0	N			
10, 11, 12	10, 11, 12			0	N			
Flared Minor-Street Approach								
Movement 9	<input type="checkbox"/> Yes	<input checked="" type="checkbox"/> No	Storage space, n	_____				
	(number of vehicles)							
Movement 12	<input type="checkbox"/> Yes	<input checked="" type="checkbox"/> No	Storage space, n	_____				
	(number of vehicles)							
Median Storage*								
* Includes raised or striped median (RM), or two-way left-turn lane (TWLTL)								
Type								
Movements 7 and 8	<input type="checkbox"/> Yes	_____	<input checked="" type="checkbox"/> No	Storage space, m	_____			
	(number of vehicles)							
Movements 10 and 11	<input type="checkbox"/> Yes	_____	<input checked="" type="checkbox"/> No	Storage space, m	_____			
	(number of vehicles)							
Upstream Signals								
	Movements	Distance to Signal, D (ft)	Prog Speed, S _{prog} (mi/h)	Cycle Length, C (s)	Green Time, g _{eff} (s)	Arrival Type	Saturation Flow Rate, s (veh/h)	Progressed Flow, V _{prog} (veh/h)
S ₂	protected LT					3		
	TH	454	35	80.0	30.0	1	3600	250
S ₅	protected LT					3		
	TH	672	35	70.0	20.0	1	3600	250
Computing Delay to Major-Street Vehicles								
Data for Computing Effect of Delay to Major-Street Vehicles				S ₂ Approach		S ₅ Approach		
Shared-lane volume, major-street through vehicles, v ₁₁ , blocked by LT								
Shared-lane volume, major-street right-turn vehicles, v ₁₂ , blocked by LT								
Saturation flow rate, major-street through vehicles, s ₁₁								
Saturation flow rate, major-street right-turn vehicles, s ₁₂								
Number of major-street through lanes								
Length of study period, T (h)								

TWSC - UNSIGNALIZED INTERSECTIONS WORKSHEET								
Worksheet 4								
General Information								
Project Description <u>Example Problem 2</u>								
Critical Gap and Follow-Up Time								
$t_c = t_{c,base} + t_{c,HV} P_{HV} + t_{c,G} G - t_{c,T} - t_{3,LT}$								
	Major LT		Minor RT		Minor TH		Minor LT	
Movement	1	4	9	12	8	11	7	10
$t_{c,base}$ (Exhibit 17-5)	4.1	4.1	6.9	6.9	6.5	6.5	7.5	7.5
$t_{c,HV}$	2.0	2.0	2.0	2.0	2.0	2.0	2.0	2.0
P_{HV} (from Worksheet 2)	0.10	0.10	0.10	0.10	0.10	0.10	0.10	0.10
$t_{c,G}$	-	-	0.1	0.1	0.2	0.2	0.2	0.2
G (from Worksheet 3)	0	0	0	0	0	0	0	0
$t_{3,LT}$	0.0	0.0	0.0	0.0	0.0	0.0	0.0	0.0
$t_{c,T}$	single stage	0.0	0.0	0.0	0.0	0.0	0.0	0.0
	two stage	-	-	-	-	-	-	-
t_c (Equation 17-1)	single stage	4.300	4.300	7.100	7.100	6.700	6.700	7.700
	two stage	-	-	-	-	-	-	-
$t_f = t_{f,base} + t_{f,HV} P_{HV}$								
	Major LT		Minor RT		Minor TH		Minor LT	
Movement	1	4	9	12	8	11	7	10
$t_{f,base}$ (Exhibit 17-5)	2.2	2.2	3.3	3.3	4.0	4.0	3.5	3.5
$t_{f,HV}$	1.0	1.0	1.0	1.0	1.0	1.0	1.0	1.0
P_{HV} (from Worksheet 2)	0.10	0.10	0.10	0.10	0.10	0.10	0.10	0.10
t_f (Equation 17-2)	2.300	2.300	3.400	3.400	4.100	4.100	3.600	3.600
Worksheet 5a								
Time to Clear Standing Queue (Computation 1)								
	Movement 2			Movement 5				
	$V_{T,prog}$		$V_{L,prot}$	$V_{T,prog}$		$V_{L,prot}$		
Effective green, g_{eff} (s)	30.0			20.0				
Cycle length, C (s)	80.0			70.0				
Saturation flow rate, s (veh/h)	3600			3600				
Arrival type	1		3	1		3		
V_{prog} (veh/h)	250			250				
R_p (from Chapter 16)	0.33		1.00	0.33		1.00		
Proportion of vehicles arriving on green, P (Equation 17-17)	0.124			0.094				
g_{q1} (Equation 17-18)	4.867			4.404				
g_{q2} (Equation 17-19)	0.114			0.103				
g_q (Equation 17-20)	4.981			4.507				

Example Problem 2

TWSC - UNSIGNALIZED INTERSECTIONS WORKSHEET				
Worksheet 5b				
General Information				
Project Description <u>Example Problem 2</u>				
Proportion of Time TWSC Intersection Is Blocked (Computation 2)				
	Movement 2		Movement 5	
	$V_{T,prog}$	$V_{L,prot}$	$V_{T,prog}$	$V_{L,prot}$
α (Exhibit 17-13)	0.50		0.50	
$\beta = (1 + \alpha)^{-1}$	0.667		0.667	
$t_a = D/S_{prog}$ (s)	8.836		14.400	
$F = (1 + \alpha\beta t_a)^{-1}$	0.253		0.172	
$f = v_{prog}/V_c \geq 0$	0.751		0.536	
$v_{c,Max}$ (Equation 17-21)	2071		1105	
$v_{c,Min} = 1000N$	2000		2000	
t_p (Equation 17-22)	0.489		0.000	
p (Equation 17-23)	0.006		0.000	
Worksheet 5c				
Platoon Event Periods (Computation 3)				
p_2 (from Worksheet 5b)		0.006		
p_5 (from Worksheet 5b)		0.000		
p_{dom} (Equation 17-24)		0.006		
p_{subo} (Equation 17-25)		0.000		
Constrained or unconstrained (Equation 17-26, 17-27)		Unconstrained		
Proportion for Minor Movements, p_x				
	Single-Stage (Exhibit 17-16)	Two-Stage		
		Stage I	Stage II	
p_1	1.000			
p_4	0.994			
p_7	0.994	1 - p_2	1 - p_5	
p_8	0.994	1 - p_2	1 - p_5	
p_9	0.994			
p_{10}	0.994	1 - p_5	1 - p_2	
p_{11}	0.994	1 - p_5	1 - p_2	
p_{12}	1.000			

TWSC - UNSIGNALIZED INTERSECTIONS WORKSHEET								
Worksheet 5d								
General Information								
Project Description	Example Problem 2							
Conflicting Flows During Unblocked Period (Computation 4)								
Single-Stage								
Movements	1	4	7	8	9	10	11	12
$v_{c,x}$ (Exhibit 17-4)	400	300	678	873	150	739	848	200
s (veh/h)	3600	3600	3600	3600	3600	3600	3600	3600
p_x (from Worksheet 5c)	1.000	0.994	0.994	0.994	0.994	0.994	0.994	1.000
$v_{c,u,x}$ (Equation 17-28)	400	280	660	857	129	722	831	200
Two-Stage								
Movements	7		8		10		11	
	Stage I	Stage II	Stage I	Stage II	Stage I	Stage II	Stage I	Stage II
$v_{c,x}$ (Exhibit 17-4)								
s (veh/h)								
p_x (from Worksheet 5c)								
$v_{c,u,x}$ (Equation 17-28)								
Worksheet 5e								
Capacity During Unblocked Period (Computation 5)								
Single-Stage								
Movements	1	4	7	8	9	10	11	12
p_x (from Worksheet 5c)	1.000	0.994	0.994	0.994	0.994	0.994	0.994	1.000
$c_{r,x}$ (Equation 17-3)	1100	1223	333	279	872	300	289	783
$c_{plat,x}$ (Equation 17-29)	1100	1216	331	277	867	298	287	783
Two-Stage								
Movements	7		8		10		11	
	Stage I	Stage II	Stage I	Stage II	Stage I	Stage II	Stage I	Stage II
p_x (from Worksheet 5c)								
$c_{r,x}$ (Equation 17-3)								
$c_{plat,x}$ (Equation 17-29)								

Example Problem 2

TWSC - UNSIGNALIZED INTERSECTIONS WORKSHEET		
Worksheet 6		
General Information		
Project Description <u>Example Problem 2</u>		
Impedance and Capacity Calculation		
Step 1: RT from Minor Street	V_9	V_{12}
Conflicting flows (Exhibit 17-4)	$V_{c,9} = 150$	$V_{c,12} = 200$
Potential capacity (Equation 17-3 or 17-29)	$C_{p,9} = 867$	$C_{p,12} = 783$
Ped impedance factor (Equation 17-12)	$P_{p,9} = 1.000$	$P_{p,12} = 1.000$
Movement capacity (Equation 17-4)	$C_{m,9} = C_{p,9} P_{p,9} = 867$	$C_{m,12} = C_{p,12} P_{p,12} = 783$
Prob of queue-free state (Equation 17-5)	$P_{0,9} = 0.937$	$P_{0,12} = 0.964$
Step 2: LT from Major Street	V_4	V_1
Conflicting flows (Exhibit 17-4)	$V_{c,4} = 300$	$V_{c,1} = 400$
Potential capacity (Equation 17-3 or 17-29)	$C_{p,4} = 1216$	$C_{p,1} = 1100$
Ped impedance factor (Equation 17-12)	$P_{p,4} = 1.000$	$P_{p,1} = 1.000$
Movement capacity (Equation 17-4)	$C_{m,4} = C_{p,4} P_{p,4} = 1216$	$C_{m,1} = C_{p,1} P_{p,1} = 1100$
Prob of queue-free state (Equation 17-5)	$P_{0,4} = 0.946$	$P_{0,1} = 0.970$
Major left shared lane prob of queue-free state (Equation 17-16)	$P_{0,4}^* =$	$P_{0,1}^* =$
Step 3: TH from Minor Street (4-leg intersections only)	V_8	V_{11}
Conflicting flows (Exhibit 17-4)	$V_{c,8} = 873$	$V_{c,11} = 848$
Potential capacity (Equation 17-3 or 17-29)	$C_{p,8} = 277$	$C_{p,11} = 287$
Ped impedance factor (Equation 17-12)	$P_{p,8} = 1.000$	$P_{p,11} = 1.000$
Capacity adjustment factor due to impeding movement (shared lane use p^*) (Equation 17-13)	$f_8 = P_{0,4} P_{0,1} P_{p,8} = 0.917$	$f_{11} = P_{0,4} P_{0,1} P_{p,11} = 0.917$
Movement capacity (Equation 17-7)	$C_{m,8} = C_{p,8} f_8 = 254$	$C_{m,11} = C_{p,11} f_{11} = 263$
Prob of queue-free state	$P_{0,8} = 0.480$	$P_{0,11} = 0.582$
Step 4: LT from Minor Street (4-leg intersections only)	V_7	V_{10}
Conflicting flows (Exhibit 17-4)	$V_{c,7} = 678$	$V_{c,10} = 739$
Potential capacity (Equation 17-3 or 17-29)	$C_{p,7} = 331$	$C_{p,10} = 298$
Ped impedance factor (Equation 17-12)	$P_{p,7} = 1.000$	$P_{p,10} = 1.000$
Major left, minor through impedance factor	$P_7^* = P_{0,11} f_{11} = 0.534$	$P_{10}^* = P_{0,8} f_8 = 0.440$
Major left, minor through adjusted impedance factor (Equation 17-8)	$P_7^* = 0.634$	$P_{10}^* = 0.556$
Capacity adjustment factor due to impeding movements (Equation 17-14)	$f_7 = P_7^* P_{0,12} P_{p,7} = 0.611$	$f_{10} = P_{10}^* P_{0,9} P_{p,10} = 0.521$
Movement capacity (Equation 17-10)	$C_{m,7} = f_7 C_{p,7} = 202$	$C_{m,10} = f_{10} C_{p,10} = 155$
Step 5: LT from Minor Street (T-intersections only)	V_7	V_{10}
Conflicting flows (Exhibit 17-4)	$V_{c,7} =$	$V_{c,10} =$
Potential capacity (Equation 17-3 or 17-29)	$C_{p,7} =$	$C_{p,10} =$
Ped impedance factor (Equation 17-12)	$P_{p,7} =$	$P_{p,10} =$
Capacity adjustment factor due to impeding movement (shared lane use p^*) (Equation 17-13)	$f_7 = P_{0,4} P_{0,1} P_{p,7} =$	$f_{10} = P_{0,4} P_{0,1} P_{p,10} =$
Movement capacity (Equation 17-7)	$C_{m,7} = C_{p,7} f_7 =$	$C_{m,10} = C_{p,10} f_{10} =$
Notes		
1. For 4-leg intersections use Steps 1, 2, 3, and 4.		
2. For T-intersections use Steps 1, 2, and 5.		

TWSC - UNSIGNALIZED INTERSECTIONS WORKSHEET							
Worksheet 8							
General Information							
Project Description <u>Example Problem 2</u>							
Shared-Lane Capacity							
$c_{SH} = \frac{\sum_y v_y}{\sum_y \left(\frac{v_y}{c_{m,y}} \right)}$ (Equation 17-15)							
Lane	v (veh/h)			c _m (veh/h)			c _{SH} (veh/h)
	Movement 7	Movement 8	Movement 9	Movement 7	Movement 8	Movement 9	
1	44	132	55	202	254	867	288
2							
3							
Lane	Movement 10	Movement 11	Movement 12	Movement 10	Movement 11	Movement 12	c _{SH} (veh/h)
1	11	110	28	155	263	783	284
2							
3							
Worksheet 9							
Effect of Flared Minor-Street Approaches							
	Lane _____			Lane _____			
	Movement 7	Movement 8	Movement 9	Movement 10	Movement 11	Movement 12	
c _{sep} (from Worksheet 6 or 7)							
volume (from Worksheet 2)							
delay (Equation 17-38)							
Q _{sep} (Equation 17-34)							
Q _{sep} + 1							
round (Q _{sep} + 1)							
n _{max} (Equation 17-35)							
c _{SH}							
c _{sep}							
n							
c _{act} (Equation 17-36)							

Example Problem 2

TWSC - UNSIGNALIZED INTERSECTIONS WORKSHEET							
Worksheet 10							
General Information							
Project Description <u>Example Problem 2</u>							
Control Delay, Queue Length, Level of Service							
Lane	v (veh/h)	c _m (veh/h)	v/c	Queue Length (Equation 17-37)	Control Delay (Equation 17-38)	LOS (Exhibit 17-2)	Delay and LOS
1 (X)(X)(X)	231	288	0.802	6	53.5	F	53.5 F
2 (7)(8)(9)							
3 (7)(8)(9)							
1 (10)(11)(12)	149	284	0.525	3	30.9	D	30.9 D
2 (10)(11)(12)							
3 (10)(11)(12)							
Movement	v (veh/h)	c _m (veh/h)	v/c	Queue Length (Equation 17-37)	Control Delay (Equation 17-38)	LOS (Exhibit 17-2)	
1	33	1100	0.030	-	8.4	A	
4	66	1216	0.054	-	8.1	A	
Worksheet 11							
Delay to Rank 1 Vehicles							
	S ₂ Approach			S ₅ Approach			
p _{0,j} (Equation 17-5)	p _{0,1} =			p _{0,4} =			
v ₁₁ , volume for Stream 2 or 5							
v ₁₂ , volume for Stream 3 or 6							
s ₁₁ , saturation flow rate for Stream 2 or 5							
s ₁₂ , saturation flow rate for Stream 3 or 6							
p _{0,j} [*] (Equation 17-16)	p _{0,1} [*] =			p _{0,4} [*] =			
d _{major left} , delay for Stream 1 or 4							
N, number of major-street through lanes							
d _{Rank 1} , delay for Stream 2 or 5 (Equation 17-39)							

EXAMPLE PROBLEM 3

The Intersection A TWSC intersection with flared approaches and a median storage. The major street is Walnut St. (EB/WB), and the minor street is Elm St. (NB/SB).

The Question What are the delay and level of service of the minor-street approaches?

The Facts

- √ Four-lane major street, √ 10 percent HV,
- √ Two-lane minor street, √ Flared approach, storage for one vehicle, and
- √ Level grade, √ Median storage, storage for two vehicles.
- √ No pedestrians,

Outline to Solution The steps below show the northbound approach calculations only. Calculations for other approaches are shown on the worksheets.

Steps

1. Data input.	Worksheets 1 and 2
2. Site characteristics.	Worksheet 3 - lane distribution, grades, right-turn channelization, flared minor-street approach, and median storage
3. t_c and t_f (use Equations 17-1 and 17-2).	Worksheet 4 - Movement 1 $t_c = t_{c,base} + t_{c,HV} P_{HV} + \dots$ $t_c = 4.1 + 2.0(0.10) + 0.0 - 0.0 - 0.0 = 4.300 \text{ s}$ $t_f = t_{f,base} + t_{f,HV} P_{HV}$ $t_f = 2.2 + 1.0(0.10) = 2.300 \text{ s}$
4. Skip Worksheets 5a through 5e.	No upstream signals within 0.25 mi
5. Movement capacity, $c_{m,x}$, for minor RT and major LT movements accounting for impedance (use Equations 17-3, 17-4, 17-5, and 17-12).	Worksheet 6 - Movement 9 $v_{c,9} = \frac{v_2}{N} + 0.5v_3 + v_{14} + v_{15}$ $v_{c,9} = \frac{250}{2} + 0.5(50) + 0 + 0 = 150 \text{ veh/h}$ $c_{p,9} = v_{c,9} \frac{e^{-v_{c,9}t_{c,9}/3,600}}{1 - e^{-v_{c,9}t_{f,9}/3,600}}$ $c_{p,9} = 150 \frac{e^{-150(7.1)/3,600}}{1 - e^{-150(3.4)/3,600}} = 845 \text{ veh/h}$ $p_{p,9} = 1.0 - f_p = 1.0 - 0.000 = 1.000$ $c_{m,9} = c_{p,9} p_{p,9} = (845)(1.000) = 845 \text{ veh/h}$ $p_{0,9} = 1 - \frac{v_9}{c_{m,9}} = 1 - \frac{55}{845} = 0.935$
6. Movement capacities, $c_{m,x}$, for minor TH and minor LT movements, accounting for impedance and two-stage gap process (use Equations 17-32, 17-33, or 17-7 and Exhibit 17-4).	Worksheets 7a and 7b $v_{c,I,8} = 341 \text{ veh/h}$ $v_{c,II,8} = 532 \text{ veh/h}$ $v_{c,8} = 873 \text{ veh/h}$ Single Stage $c_{m,8} = c_{p,8} f_8 = 273(0.917) = 250 \text{ veh/h}$ Two-Stage $c_T = \frac{\alpha}{y^{m+1} - 1} [y(y^m - 1) \dots]$ $c_T = \frac{0.949}{1.808^{2+1} - 1} [1.808(1.808^2 - 1) \dots] = 390 \text{ veh/h}$

<p>7. Shared-lane capacity (use Equation 17-15).</p>	<p>Worksheet 8</p> $c_{SH} = \frac{\sum v_y}{\sum \frac{v_y}{c_m}}$ $c_{SH} (NB) = \frac{44 + 132 + 55}{\frac{44}{370} + \frac{132}{390} + \frac{55}{845}} = 442 \text{ veh/h}$
<p>8. Flared approach capacity (use Equations 17-36 and 17-38).</p>	<p>Worksheet 9 - Movement 7</p> $d = \frac{3,600}{c_{m,x}} + 900T[\dots] + 5$ $d = \frac{3,600}{369} + 900(0.25)[\dots] + 5 = 16.070 \text{ s}$ $Q_{sep} = \frac{d_7 v_7}{3,600} = \frac{(16.0)(44)}{3,600} = 0.196$ $c_{act} (NB) = \left(\sum_i c_{sep} - c_{SH} \right) \frac{n}{n_{Max}} + c_{SH}$ $c_{act} = (1,605 - 442) \frac{1}{2} + 442 = 1,024 \text{ veh/h}$
<p>9. Control delay and LOS (use Equation 17-38 and Exhibit 17-2).</p>	<p>Worksheet 10</p> $d_{NB} = \frac{3,600}{c_{m,x}} + 900T[\dots] + 5$ $d_{NB} = \frac{3,600}{1,024} + 900(0.05)[\dots] + 5 = 9.5 \text{ s}$ <p>LOS A</p>
<p>10. Skip Worksheet 11.</p>	<p>No Rank 1 vehicle delay</p>

TWSC - UNSIGNALIZED INTERSECTIONS WORKSHEET

Worksheet 1

General Information	Site Information
Analyst <u>JME</u>	Intersection <u>Walnut/Elm</u>
Agency or Company <u>CEI</u>	Jurisdiction <u>Latah County</u>
Date Performed <u>5/7/99</u>	Analysis Year <u>1999</u>
Analysis Time Period <u>AM Peak</u>	

Geometrics and Movements

Length of study period = 0.25 h

Worksheet 2

Vehicle Volumes and Adjustments

Movement	Vehicle Volumes and Adjustments											
	1	2	3	4	5	6	7	8	9	10	11	12
Volume (veh/h)	33	250	50	66	300	100	44	132	55	11	110	28
Peak-hour factor, PHF	1.00	1.00	1.00	1.00	1.00	1.00	1.00	1.00	1.00	1.00	1.00	1.00
Hourly flow rate (veh/h)	33	250	50	66	300	100	44	132	55	11	110	28
Proportion of heavy vehicles, P _{HV}	0.10	0.10	0.10	0.10	0.10	0.10	0.10	0.10	0.10	0.10	0.10	0.10

Pedestrian Volumes and Adjustments

Movement	13	14	15	16
Flow, V _x (ped/h)	0	0	0	0
Lane width, w (ft)				
Walking speed, ¹ S _p (ft/s)				
Percent blockage, f _p (Equation 17-11)				

1. Default walking speed = 4.0 ft/s

Example Problem 3

TWSC - UNSIGNALIZED INTERSECTIONS WORKSHEET								
Worksheet 3								
General Information								
Project Description <u>Example Problem 3</u>								
Lane Designation								
Movements	Lane 1	Lane 2	Lane 3	Grade, G	Right Turn Channelized?			
1, 2, 3	1	2	2, 3	0	N			
4, 5, 6	4	5	5, 6	0	N			
7, 8, 9	7, 8, 9			0	N			
10, 11, 12	10, 11, 12			0	N			
Flared Minor-Street Approach								
Movement 9	<input checked="" type="checkbox"/> Yes	<input type="checkbox"/> No	Storage space, n	$\frac{1}{\text{(number of vehicles)}}$				
Movement 12	<input checked="" type="checkbox"/> Yes	<input type="checkbox"/> No	Storage space, n	$\frac{1}{\text{(number of vehicles)}}$				
Median Storage*								
* Includes raised or striped median (RM), or two-way left-turn lane (TWLTL)								
Type								
Movements 7 and 8	<input checked="" type="checkbox"/> Yes	<u>RM</u>	<input type="checkbox"/> No	Storage space, m	$\frac{2}{\text{(number of vehicles)}}$			
Movements 10 and 11	<input checked="" type="checkbox"/> Yes	<u>RM</u>	<input type="checkbox"/> No	Storage space, m	$\frac{2}{\text{(number of vehicles)}}$			
Upstream Signals								
	Movements	Distance to Signal, D (ft)	Prog Speed, S_{prog} (mi/h)	Cycle Length, C (s)	Green Time, g_{eff} (s)	Arrival Type	Saturation Flow Rate, s (veh/h)	Progressed Flow, V_{prog} (veh/h)
S_2	protected LT					3		
	TH							
S_5	protected LT					3		
	TH							
Computing Delay to Major-Street Vehicles								
Data for Computing Effect of Delay to Major-Street Vehicles				S_2 Approach		S_5 Approach		
Shared-lane volume, major-street through vehicles, v_{11} , blocked by LT								
Shared-lane volume, major-street right-turn vehicles, v_{12} , blocked by LT								
Saturation flow rate, major-street through vehicles, s_{11}								
Saturation flow rate, major-street right-turn vehicles, s_{12}								
Number of major-street through lanes								
Length of study period, T (h)								

TWSC - UNSIGNALIZED INTERSECTIONS WORKSHEET								
Worksheet 4								
General Information								
Project Description <u>Example Problem 3</u>								
Critical Gap and Follow-Up Time								
$t_c = t_{c,base} + t_{c,HV} P_{HV} + t_{c,G} G - t_{c,T} - t_{3,LT}$								
	Major LT		Minor RT		Minor TH		Minor LT	
Movement	1	4	9	12	8	11	7	10
$t_{c,base}$ (Exhibit 17-5)	4.1	4.1	6.9	6.9	6.5	6.5	7.5	7.5
$t_{c,HV}$	2.0	2.0	2.0	2.0	2.0	2.0	2.0	2.0
P_{HV} (from Worksheet 2)	0.10	0.10	0.10	0.10	0.10	0.10	0.10	0.10
$t_{c,G}$	-	-	0.1	0.1	0.2	0.2	0.2	0.2
G (from Worksheet 3)	0	0	0	0	0	0	0	0
$t_{3,LT}$	0.0	0.0	0.0	0.0	0.0	0.0	0.0	0.0
$t_{c,T}$	single stage	0.0	0.0	0.0	0.0	0.0	0.0	0.0
	two stage	-	-	-	-	1.0	1.0	1.0
t_c (Equation 17-1)	single stage	4.300	4.300	7.100	7.100	6.700	6.700	7.700
	two stage	-	-	-	-	5.700	5.700	6.700
$t_f = t_{f,base} + t_{f,HV} P_{HV}$								
	Major LT		Minor RT		Minor TH		Minor LT	
Movement	1	4	9	12	8	11	7	10
$t_{f,base}$ (Exhibit 17-5)	2.2	2.2	3.3	3.3	4.0	4.0	3.5	3.5
$t_{f,HV}$	1.0	1.0	1.0	1.0	1.0	1.0	1.0	1.0
P_{HV} (from Worksheet 2)	0.10	0.10	0.10	0.10	0.10	0.10	0.10	0.10
t_f (Equation 17-2)	2.300	2.300	3.400	3.400	4.100	4.100	3.600	3.600
Worksheet 5a								
Time to Clear Standing Queue (Computation 1)								
	Movement 2				Movement 5			
	$V_{T,prog}$	$V_{L,prot}$			$V_{T,prog}$	$V_{L,prot}$		
Effective green, g_{eff} (s)								
Cycle length, C (s)								
Saturation flow rate, s (veh/h)								
Arrival type			3				3	
V_{prog} (veh/h)								
R_p (from Chapter 16)			1.00				1.00	
Proportion of vehicles arriving on green, P (Equation 17-17)								
g_{q1} (Equation 17-18)								
g_{q2} (Equation 17-19)								
g_q (Equation 17-20)								

Example Problem 3

TWSC - UNSIGNALIZED INTERSECTIONS WORKSHEET		
Worksheet 6		
General Information		
Project Description <u>Example Problem 3</u>		
Impedance and Capacity Calculation		
Step 1: RT from Minor Street	V_9	V_{12}
Conflicting flows (Exhibit 17-4)	$V_{c,9} = 150$	$V_{c,12} = 200$
Potential capacity (Equation 17-3 or 17-29)	$C_{p,9} = 845$	$C_{p,12} = 783$
Ped impedance factor (Equation 17-12)	$P_{p,9} = 1.000$	$P_{p,12} = 1.000$
Movement capacity (Equation 17-4)	$C_{m,9} = C_{p,9} P_{p,9} = 845$	$C_{m,12} = C_{p,12} P_{p,12} = 783$
Prob of queue-free state (Equation 17-5)	$P_{0,9} = 0.935$	$P_{0,12} = 0.964$
Step 2: LT from Major Street	V_4	V_1
Conflicting flows (Exhibit 17-4)	$V_{c,4} = 300$	$V_{c,1} = 400$
Potential capacity (Equation 17-3 or 17-29)	$C_{p,4} = 1202$	$C_{p,1} = 1100$
Ped impedance factor (Equation 17-12)	$P_{p,4} = 1.000$	$P_{p,1} = 1.000$
Movement capacity (Equation 17-4)	$C_{m,4} = C_{p,4} P_{p,4} = 1202$	$C_{m,1} = C_{p,1} P_{p,1} = 1100$
Prob of queue-free state (Equation 17-5)	$P_{0,4} = 0.945$	$P_{0,1} = 0.970$
Major left shared lane prob of queue-free state (Equation 17-16)	$P_{0,4}^* =$	$P_{0,1}^* =$
Step 3: TH from Minor Street (4-leg intersections only)	V_8	V_{11}
Conflicting flows (Exhibit 17-4)	$V_{c,8} =$	$V_{c,11} =$
Potential capacity (Equation 17-3 or 17-29)	$C_{p,8} =$	$C_{p,11} =$
Ped impedance factor (Equation 17-12)	$P_{p,8} =$	$P_{p,11} =$
Capacity adjustment factor due to impeding movement (shared lane use p^*) (Equation 17-13)	$f_8 = P_{0,4} P_{0,1} P_{p,8} =$	$f_{11} = P_{0,4} P_{0,1} P_{p,11} =$
Movement capacity (Equation 17-7)	$C_{m,8} = C_{p,8} f_8 =$	$C_{m,11} = C_{p,11} f_{11} =$
Prob of queue-free state	$P_{0,8} =$	$P_{0,11} =$
Step 4: LT from Minor Street (4-leg intersections only)	V_7	V_{10}
Conflicting flows (Exhibit 17-4)	$V_{c,7} =$	$V_{c,10} =$
Potential capacity (Equation 17-3 or 17-29)	$C_{p,7} =$	$C_{p,10} =$
Ped impedance factor (Equation 17-12)	$P_{p,7} =$	$P_{p,10} =$
Major left, minor through impedance factor	$P_7^* = P_{0,11} f_{11} =$	$P_{10}^* = P_{0,8} f_8 =$
Major left, minor through adjusted impedance factor (Equation 17-8)	$P_7' =$	$P_{10}' =$
Capacity adjustment factor due to impeding movements (Equation 17-14)	$f_7 = P_7' P_{0,12} P_{p,7} =$	$f_{10} = P_{10}' P_{0,9} P_{p,10} =$
Movement capacity (Equation 17-10)	$C_{m,7} = f_7 C_{p,7} =$	$C_{m,10} = f_{10} C_{p,10} =$
Step 5: LT from Minor Street (T-intersections only)	V_7	V_{10}
Conflicting flows (Exhibit 17-4)	$V_{c,7} =$	$V_{c,10} =$
Potential capacity (Equation 17-3 or 17-29)	$C_{p,7} =$	$C_{p,10} =$
Ped impedance factor (Equation 17-12)	$P_{p,7} =$	$P_{p,10} =$
Capacity adjustment factor due to impeding movement (shared lane use p^*) (Equation 17-13)	$f_7 = P_{0,4} P_{0,1} P_{p,7} =$	$f_{10} = P_{0,4} P_{0,1} P_{p,10} =$
Movement capacity (Equation 17-7)	$C_{m,7} = C_{p,7} f_7 =$	$C_{m,10} = C_{p,10} f_{10} =$
Notes		
1. For 4-leg intersections use Steps 1, 2, 3, and 4.		
2. For T-intersections use Steps 1, 2, and 5.		

TWSC - UNSIGNALIZED INTERSECTIONS WORKSHEET		
Worksheet 7a		
General Information		
Project Description <u>Example Problem 3</u>		
Effect of Two-Stage Gap Acceptance		
Step 3: TH from Minor Street	V_8	V_{11}
Part I - First Stage		
Conflicting flows (Exhibit 17-4)	$V_{c,I,8} = 341$	$V_{c,I,11} = 482$
Potential capacity (Equation 17-3 or 17-29)	$C_{p,I,8} = 618$	$C_{p,I,11} = 532$
Ped impedance factor (Equation 17-12)	$P_{p,I,8} = 1.000$	$P_{p,I,11} = 1.000$
Capacity adjustment factor due to impeding movement (shared lane use p^*) (Equation 17-6 or 17-13)	$f_{i,8} = P_{0,1} P_{p,I,8} = 0.970$	$f_{i,11} = P_{0,4} P_{p,I,11} = 0.945$
Movement capacity (Equation 17-7)	$C_{m,I,8} = C_{p,I,8} f_{i,8} = 599$	$C_{m,I,11} = C_{p,I,11} f_{i,11} = 503$
Prob of queue-free state (Equation 17-5)	$P_{0,I,8} = 0.780$	$P_{0,I,11} = 0.781$
Part II - Second Stage		
Conflicting flows (Exhibit 17-4)	$V_{c,II,8} = 532$	$V_{c,II,11} = 366$
Potential capacity (Equation 17-3 or 17-29)	$C_{p,II,8} = 504$	$C_{p,II,11} = 601$
Ped impedance factor (Equation 17-12)	$P_{p,II,8} = 1.000$	$P_{p,II,11} = 1.000$
Capacity adjustment factor due to impeding movement (shared lane use p^*) (Equation 17-6 or 17-13)	$f_{i,II,8} = P_{0,4} P_{p,II,8} = 0.945$	$f_{i,II,11} = P_{0,1} P_{p,II,11} = 0.970$
Movement capacity (Equation 17-7)	$C_{m,II,8} = C_{p,II,8} f_{i,II,8} = 476$	$C_{m,II,11} = C_{p,II,11} f_{i,II,11} = 583$
Prob of queue-free state (Equation 17-5)	$P_{0,II,8} = 0.723$	$P_{0,II,11} = 0.811$
Part III - Single Stage		
Conflicting flows (Exhibit 17-4)	$V_{c,8} = 873$	$V_{c,11} = 848$
Potential capacity (Equation 17-3 or 17-29)	$C_{p,8} = 273$	$C_{p,11} = 283$
Ped impedance factor (Equation 17-12)	$P_{p,8} = 1.000$	$P_{p,11} = 1.000$
Capacity adjustment factor due to impeding movement (shared lane use p^*) (Equation 17-13 or 17-16)	$f_{i,8} = P_{0,4} P_{0,1} P_{p,8} = 0.917$	$f_{i,11} = P_{0,4} P_{0,1} P_{p,11} = 0.917$
Movement capacity (Equation 17-7)	$C_{m,8} = C_{p,8} f_{i,8} = 250$	$C_{m,11} = C_{p,11} f_{i,11} = 260$
Result for Two-Stage Process		
a (Equation 17-30)	a = 0.949	a = 0.949
y (Equation 17-31)	y = 1.808	y = 0.946
C_T (Equation 17-32 or 17-33)	$C_T = 390$	$C_T = 405$
Prob of queue-free state (Equation 17-5)	$P_{0,8} = 0.662$	$P_{0,11} = 0.728$

Example Problem 3

TWSC - UNSIGNALIZED INTERSECTIONS WORKSHEET		
Worksheet 7b		
General Information		
Project Description <u>Example Problem 3</u>		
Effect of Two-Stage Gap Acceptance		
Step 4: LT from Minor Street	V_7	V_{10}
Part I - First Stage		
Conflicting flows (Exhibit 17-4)	$V_{c,1,7} = 341$	$V_{c,1,10} = 482$
Potential capacity (Equation 17-3 or 17-29)	$C_{p,1,7} = 626$	$C_{p,1,10} = 514$
Ped impedance factor (Equation 17-12)	$P_{p,1,7} = 1.000$	$P_{p,1,10} = 1.000$
Capacity adjustment factor due to impeding movements	$f_{1,7} = P_{0,1} P_{p,1,7} = 0.970$	$f_{1,10} = P_{0,4} P_{p,1,10} = 0.945$
Movement capacity (Equation 17-7)	$C_{m,1,7} = f_{1,7} C_{p,1,7} = 607$	$C_{m,1,10} = f_{1,10} C_{p,1,10} = 486$
Part II - Second Stage		
Conflicting flows (Exhibit 17-4)	$V_{c,II,7} = 337$	$V_{c,II,10} = 257$
Potential capacity (Equation 17-3 or 17-29)	$C_{p,II,7} = 629$	$C_{p,II,10} = 703$
Ped impedance factor (Equation 17-12)	$P_{p,II,7} = 1.000$	$P_{p,II,10} = 1.000$
Capacity adjustment factor due to impeding movements	$f_{II,7} = P_{0,4} P_{0,1,11} P_{0,12} P_{p,II,7} = 0.711$	$f_{II,10} = P_{0,1} P_{0,1,8} P_{0,9} P_{p,II,10} = 0.707$
Movement capacity (Equation 17-7)	$C_{m,II,7} = f_{II,7} C_{p,II,7} = 447$	$C_{m,II,10} = f_{II,10} C_{p,II,10} = 497$
Part III - Single-Stage		
Conflicting flows (Exhibit 17-4)	$V_{c,7} = 678$	$V_{c,10} = 739$
Potential capacity (Equation 17-3 or 17-29)	$C_{p,7} = 323$	$C_{p,10} = 291$
Ped impedance factor (Equation 17-12)	$P_{p,7} = 1.000$	$P_{p,10} = 1.000$
Major left, minor through impedance factor	$P_7^* = P_{0,11} f_{11} = 0.668$	$P_{10}^* = P_{0,8} f_8 = 0.607$
Major left, minor through adjusted impedance factor (Equation 17-8)	$P_7^{\dagger} = 0.742$	$P_{10}^{\dagger} = 0.694$
Capacity adjustment factor due to impeding movements (Equation 17-9 or 17-14)	$f_7 = P_7^{\dagger} P_{0,12} P_{p,7} = 0.715$	$f_{10} = P_{10}^{\dagger} P_{0,9} P_{p,10} = 0.649$
Movement capacity (Equation 17-7)	$C_{m,7} = f_7 C_{p,7} = 231$	$C_{m,10} = f_{10} C_{p,10} = 189$
Result for Two-Stage Process		
a (Equation 17-30)	a = 0.949	a = 0.949
y (Equation 17-31)	y = 2.055	y = 1.227
c_T (Equation 17-32 or 17-33)	$c_T = 369$	$c_T = 347$

TWSC - UNSIGNALIZED INTERSECTIONS WORKSHEET							
Worksheet 8							
General Information							
Project Description <u>Example Problem 3</u>							
Shared-Lane Capacity							
$c_{SH} = \frac{\sum v_y}{y} \left(\frac{y}{\sum \left(\frac{v_y}{c_{m,y}} \right)} \right) \quad \text{(Equation 17-15)}$							
Lane	v (veh/h)			c _m (veh/h)			c _{SH} (veh/h)
	Movement 7	Movement 8	Movement 9	Movement 7	Movement 8	Movement 9	
1	44	132	55	369	390	845	442
2							
3							
Lane	Movement 10	Movement 11	Movement 12	Movement 10	Movement 11	Movement 12	c _{SH} (veh/h)
1	11	110	28	347	405	783	439
2							
3							
Worksheet 9							
Effect of Flared Minor-Street Approaches							
	Lane <u>1</u>			Lane <u>1</u>			
	Movement 7	Movement 8	Movement 9	Movement 10	Movement 11	Movement 12	
c _{sep} (from Worksheet 6 or 7)	369	390	845	347	405	783	
volume (from Worksheet 2)	44	132	55	11	110	28	
delay (Equation 17-38)	16.070	18.881	9.557	15.714	17.171	9.768	
Q _{sep} (Equation 17-34)	0.196	0.692	0.146	0.048	0.525	0.076	
Q _{sep} + 1	1.196	1.692	1.146	1.048	1.525	1.076	
round (Q _{sep} + 1)	1	2	1	1	2	1	
n _{max} (Equation 17-35)	2			2			
c _{SH}	442			439			
c _{sep}	1604			1535			
n	1			1			
c _{act} (Equation 17-36)	1023			987			

Example Problem 3

TWSC - UNSIGNALIZED INTERSECTIONS WORKSHEET

Worksheet 10

General Information

Project Description Example Problem 3

Control Delay, Queue Length, Level of Service

Lane	v (veh/h)	c _m (veh/h)	v/c	Queue Length (Equation 17-37)	Control Delay (Equation 17-38)	LOS (Exhibit 17-2)	Delay and LOS
1 (X) (X) (X)	231	1024	0.226	< 1	9.5	A	9.5 A
2 (7) (8) (9)							
3 (7) (8) (9)							
1 (X) (X) (X)	149	987	0.151	< 1	9.3	A	9.3 A
2 (10) (11) (12)							
3 (10) (11) (12)							

Movement	v (veh/h)	c _m (veh/h)	v/c	Queue Length (Equation 17-37)	Control Delay (Equation 17-38)	LOS (Exhibit 17-2)
1	33	1100	0.030	< 1	8.4	A
4	66	1216	0.055	< 1	8.2	A

Worksheet 11

Delay to Rank 1 Vehicles

	S ₂ Approach	S ₅ Approach
p _{0,j} (Equation 17-5)	p _{0,1} =	p _{0,4} =
v ₁ , volume for Stream 2 or 5		
v ₂ , volume for Stream 3 or 6		
s ₁ , saturation flow rate for Stream 2 or 5		
s ₂ , saturation flow rate for Stream 3 or 6		
p _{0,j} [*] (Equation 17-16)	p _{0,1} [*] =	p _{0,4} [*] =
d _{major left} , delay for Stream 1 or 4		
N, number of major-street through lanes		
d _{Rank 1} , delay for Stream 2 or 5 (Equation 17-39)		

EXAMPLE PROBLEM 4

The Intersection An AWSC T-intersection with one lane on each approach.

The Question What are the delay and level of service?

The Facts

- √ Two two-lane streets, and
- √ No heavy vehicles.

Comments The use of spreadsheet software is recommended because of the repetitive computations required. The degree of utilization, x , computed in each iteration is used to determine the departure headway of the next iteration. Slight differences in estimated headways may result from rounding differences in manual (handheld calculator) computations or from rounding differences between manual and software computations.

Outline to Solution The steps below show the southbound approach calculations only. Calculations for other approaches are shown on the worksheets.

Steps

<p>1. Data input and volume adjustments.</p>	<p>Worksheets 1 and 2</p> $v_x = \frac{\text{Volume}}{\text{PHF}}$ $v_{SB} = \frac{100}{1.00} = 100 \text{ veh/h}$
<p>2. Saturation headway adjustment factor (use Equation 17-56).</p>	<p>Worksheet 3</p> $h_{adj} = h_{LT-adj} P_{LT} + h_{RT-adj} P_{RT} + h_{HV-adj} P_{HV}$ <p>SB $h_{adj} = (0.2)0.67 + (-0.6)0.333 + (1.7)0 = -0.066$</p>
<p>3. Departure headway, service time, probability status, and saturation headway.</p> <p>Probability state for case-conflict combinations (use Equation 17-58 and Exhibit 17-26).</p> <p>Probability of degree-of-conflict cases (use Equations 17-47 through 17-51).</p> <p>Probability adjustment factors (use Equations 17-64 through 17-68).</p> <p>Adjusted probability (use Equation 17-69).</p> <p>Saturation headway.</p> <p>Departure headway (use Equation 17-54).</p>	<p>Worksheets 4a and 4b</p> <p>Since a NB approach does not exist, its volume is 0. Hence, its probability of a vehicle present, $P(a = 1)$, is also 0. Worksheet 4b is used to determine the departure headway. For each iteration, a separate worksheet is required for each lane. In total, three worksheets are required for this intersection with one-lane approaches.</p> $P(i) = \prod_j P(a_j)$ $P(1) = P(a_{01}) P(a_{CL1}) P(a_{CR1})$ $P(1) = (1.000) (0.644)(0.689) = 0.444$ $P(C_1) = P(1) = 0.444$ $\text{Adj}P(1) = \alpha [P(C_2) + 2P(C_3) + 3P(C_4) + 4P(C_5)]/n$ $\text{Adj}P(1) = 0.012$ <p>n varies from case to case and from approach to approach. It is the number of conflict combinations in each case.</p> $P'(i) = P(i) + \text{Adj}P(i)$ $P'(1) = 0.444 + 0.012 = 0.456$ $h_{si} = h_{adj} + h_{base}$ $h_{si} = -0.066 + 3.9 = 3.834$ $\text{SB } h_d = \sum_{i=1}^{64} P'(i) h_{si} = 4.954$

<p>3. (continued) Repeat the process until the change in headways between two successive iterations is less than 0.100 s.</p>	
<p>4. Service time and capacity (use Equation 17-53). Capacity is determined by increasing the subject lane volume while holding other volumes constant. The capacity is reached when $x = 1.000$.</p> <p>Control delay and LOS (use Equation 17-55 and Exhibit 17-19).</p> <p>The intersection delay is the weighted average of individual delays.</p>	<p>Worksheet 5</p> <p>$s = h_d - m$</p> <p>SB $s = 5.39 - 2.00 = 3.39$ s</p> <p>$d = s + 900T[\dots] + 5$</p> <p>SB $d = 3.47 + 900(0.25)[\dots] + 5 = 10.1$ s, LOS B</p>

AWSC - UNSIGNALIZED INTERSECTIONS WORKSHEET								
Worksheet 1								
General Information				Site Information				
Analyst	<u>ETA</u>	Intersection	<u>Sixth/Line</u>	Agency or Company	<u>CEI</u>	Jurisdiction	<u>Latah County</u>	
Date Performed	<u>5/21/99</u>	Analysis Year	<u>1999</u>	Analysis Time Period	<u>AM Peak</u>			
Geometrics and Movements								
<p style="margin-top: 10px;">Data Required: Vehicle volumes by movement Proportion of heavy vehicles</p> <p style="text-align: right;">Length of study period = <u>0.25</u> h</p>								
Worksheet 2								
Volume Adjustments and Lane Assignments								
Approach		Lane 1			Lane 2			Geometry Group (Exhibit 17-32)
		LT	TH	RT	LT	TH	RT	
EB	Volume (veh/h)	50	300					1
	PHF	1.00						
	% Heavy vehicle	0						
	Flow rate (veh/h)	50	300					
WB	Volume (veh/h)		300	100				1
	PHF	1.00						
	% Heavy vehicle		0	0				
	Flow rate (veh/h)		300	100				
NB	Volume (veh/h)							
	PHF							
	% Heavy vehicle							
	Flow rate (veh/h)							
SB	Volume (veh/h)	100		50				1
	PHF	1.00						
	% Heavy vehicle	0						
	Flow rate (veh/h)	100		50				

Example Problem 4

AWSC - UNSIGNALIZED INTERSECTIONS WORKSHEET								
Worksheet 3								
General Information								
Project Description <u>Example Problem 4</u>								
Saturation Headways								
	EB		WB		NB		SB	
	L1	L2	L1	L2	L1	L2	L1	L2
Total lane flow rate	350		400				150	
Left-turn flow rate in lane	50		0				100	
Right-turn flow rate in lane	0		100				50	
Proportion LT in lane	0.143		0.000				0.667	
Proportion RT in lane	0.000		0.250				0.333	
Proportion HV in lane	0		0				0	
h_{LT-adj} (Exhibit 17-33)	0.2		0.2				0.2	
h_{RT-adj} (Exhibit 17-33)	-0.6		-0.6				-0.6	
h_{HV-adj} (Exhibit 17-33)	1.7		1.7				1.7	
h_{adj} (Equation 17-56)	0.029		-0.150				-0.066	
Worksheet 4a								
Departure Headway								
	EB		WB		NB		SB	
	L1	L2	L1	L2	L1	L2	L1	L2
Total lane flow rate	350		400				150	
h_d , initial value (s)	3.2	3.2	3.2	3.2	3.2	3.2	3.2	3.2
x , initial value (Equation 17-57)	0.311		0.356				0.133	
h_d , Iteration 1	4.472		4.261				4.954	
h_d , difference	1.272		1.061				1.754	
h_d , Iteration 2	4.715		4.499				5.318	
h_d , difference	0.243		0.238				0.364	
h_d , Iteration 3	4.773		4.555				5.390	
h_d , difference	0.058		0.056				0.072	
h_d , Iteration 4								
h_d , difference								
h_d , Iteration 5								
h_d , difference								
Convergence?	Y		Y				Y	
h_d , final	4.773		4.555				5.390	
x , final	0.464		0.506				0.225	

Example Problem 4

AWSC - UNSIGNALIZED INTERSECTIONS WORKSHEET												
Worksheet 4b												
Project Description <u>Example Problem 4, SB Iteration 1</u>												
Service Time												
i	P(a _{n1})	P(a _{n2})	P(a _{n11})	P(a _{n12})	P(a _{nR1})	P(a _{nR2})	P(i)	Adj P(i)	P'(i)	h _{base}	h _{adj}	h _{sl}
1	1.000		0.644		0.689		0.444	0.012	0.456	3.9	-0.066	3.834
2	0.000		0.644		0.689		0.000					
3												
4												
5												
6	1.000		0.356		0.689		0.245	-0.006	0.239	5.8	-0.066	5.734
7	1.000		0.644		0.311		0.200	-0.006	0.194	5.8	-0.066	5.734
8												
9												
10												
11												
12												
13	1.000		0.356		0.311		0.111	-0.007	0.104	7.0	-0.066	6.934
14												
15												
16	0.000		0.356		0.689		0.000					
17												
18												
19												
20												
21	0.000		0.644		0.311		0.000					
22												
23												
24												
25												
26												
27												
28												
29												
30												
31												
32												
33												
34												
35												
36												
37												
38												
39												
40												
41												
42												
43												
44												
45												
46												
47												
48												
49												
50												
51												
52												
53												
54												
55												
56												
57												
58												
59												
60												
61												
62												
63												
64	0.000		0.356		0.311		0.000					

Example Problem 4

Iteration 1										
SBL1										
i	P(a _{opp1})	P(a _{CL1})	P(a _{CR1})	P(i)	Adj P(i)	P'(i)	h _{base}	h _{adj}	h _{si}	P'(i)*h _{si}
1	1.000	0.644	0.689	0.444	0.012	0.456	3.900	-0.066	3.834	1.748
2	0.000	0.644	0.689	0.000						
6	1.000	0.356	0.689	0.245	-0.006	0.239	5.800	-0.066	5.734	1.371
7	1.000	0.644	0.311	0.200	-0.006	0.194	5.800	-0.066	5.734	1.113
13	1.000	0.356	0.311	0.111	-0.007	0.104	7.000	-0.066	6.934	0.722
16	0.000	0.356	0.689	0.000						
21	0.000	0.644	0.311	0.000						
64	0.000	0.356	0.311	0.000						
									h _d	4.954

EBL1										
i	P(a _{opp1})	P(a _{CL1})	P(a _{CR1})	P(i)	Adj P(i)	P'(i)	h _{base}	h _{adj}	h _{si}	P'(i)*h _{si}
1	0.644	0.867	1.000	0.558	0.006	0.565	3.900	0.029	3.929	2.218
2	0.356	0.867	1.000	0.309	-0.001	0.307	4.700	0.029	4.729	1.454
6	0.644	0.133	1.000	0.086	-0.002	0.084	5.800	0.029	5.829	0.487
7	0.644	0.867	0.000	0.000						
13	0.644	0.133	0.000	0.000						
16	0.356	0.133	1.000	0.047	-0.003	0.045	7.000	0.029	7.029	0.313
21	0.356	0.867	0.000	0.000						
64	0.356	0.133	0.000	0.000						
									h _d	4.472

WBL1										
i	P(a _{opp1})	P(a _{CL1})	P(a _{CR1})	P(i)	Adj P(i)	P'(i)	h _{base}	h _{adj}	h _{si}	P'(i)*h _{si}
1	0.689	1.000	0.867	0.597	0.006	0.603	3.900	-0.150	3.750	2.263
2	0.311	1.000	0.867	0.270	-0.001	0.269	4.700	-0.150	4.550	1.222
6	0.689	0.000	0.867	0.000						
7	0.689	1.000	0.133	0.092	-0.002	0.090	5.800	-0.150	5.650	0.506
13	0.689	0.000	0.133	0.000						
16	0.311	0.000	0.867	0.000						
21	0.311	1.000	0.133	0.041	-0.002	0.039	7.000	-0.150	6.850	0.270
64	0.311	0.000	0.133	0.000						
									h _d	4.261

Example Problem 4

Iteration 2										
SBL1										
i	P(a _{opp1})	P(a _{CL1})	P(a _{CR1})	P(i)	Adj P(i)	P'(i)	h _{base}	h _{adj}	h _{si}	P'(i)*h _{si}
1	1.000	0.527	0.565	0.298	0.016	0.314	3.900	-0.066	3.834	1.203
2	0.000	0.527	0.565	0.000						
6	1.000	0.473	0.565	0.267	-0.006	0.261	5.800	-0.066	5.734	1.496
7	1.000	0.527	0.435	0.229	-0.006	0.223	5.800	-0.066	5.734	1.278
13	1.000	0.473	0.435	0.206	-0.012	0.193	7.000	-0.066	6.934	1.341
16	0.000	0.473	0.565	0.000						
21	0.000	0.527	0.435	0.000						
64	0.000	0.473	0.435	0.000						
									h _d	5.318

EBL1										
i	P(a _{opp1})	P(a _{CL1})	P(a _{CR1})	P(i)	Adj P(i)	P'(i)	h _{base}	h _{adj}	h _{si}	P'(i)*h _{si}
1	0.527	0.794	1.000	0.418	0.009	0.427	3.900	0.029	3.929	1.679
2	0.473	0.794	1.000	0.376	-0.001	0.375	4.700	0.029	4.729	1.773
6	0.527	0.206	1.000	0.109	-0.002	0.106	5.800	0.029	5.829	0.620
7	0.527	0.794	0.000	0.000						
13	0.527	0.206	0.000	0.000						
16	0.473	0.206	1.000	0.097	-0.006	0.092	7.000	0.029	7.029	0.644
21	0.473	0.794	0.000	0.000						
64	0.473	0.206	0.000	0.000						
									h _d	4.715

WBL1										
i	P(a _{opp1})	P(a _{CL1})	P(a _{CR1})	P(i)	Adj P(i)	P'(i)	h _{base}	h _{adj}	h _{si}	P'(i)*h _{si}
1	0.565	1.000	0.794	0.449	0.008	0.457	3.900	-0.150	3.750	1.712
2	0.435	1.000	0.794	0.345	-0.001	0.344	4.700	-0.150	4.550	1.567
6	0.565	0.000	0.794	0.000						
7	0.565	1.000	0.206	0.116	-0.003	0.113	5.800	-0.150	5.650	0.641
13	0.565	0.000	0.206	0.000						
16	0.435	0.000	0.794	0.000						
21	0.435	1.000	0.206	0.090	-0.005	0.085	7.000	-0.150	6.850	0.580
64	0.435	0.000	0.206	0.000						
									h _d	4.499

Example Problem 4

Iteration 3										
SBL1										
i	P(a _{opp1})	P(a _{CL1})	P(a _{CR1})	P(i)	Adj P(i)	P'(i)	h _{base}	h _{adj}	h _{si}	P'(i)*h _{si}
1	1.000	0.5	0.542	0.271	0.017	0.288	3.900	-0.066	3.834	1.104
2	0.000	0.5	0.542	0.000						
6	1.000	0.5	0.542	0.271	-0.006	0.265	5.800	-0.066	5.734	1.517
7	1.000	0.5	0.458	0.229	-0.006	0.223	5.800	-0.066	5.734	1.277
13	1.000	0.5	0.458	0.229	-0.014	0.215	7.000	-0.066	6.934	1.493
16	0.000	0.5	0.542	0.000						
21	0.000	0.5	0.458	0.000						
64	0.000	0.5	0.458	0.000						
									h _d	5.390

EBL1										
i	P(a _{opp1})	P(a _{CL1})	P(a _{CR1})	P(i)	Adj P(i)	P'(i)	h _{base}	h _{adj}	h _{si}	P'(i)*h _{si}
1	0.500	0.778	1.000	0.389	0.006	0.395	3.900	0.029	3.929	1.550
2	0.500	0.778	1.000	0.389	0.003	0.392	4.700	0.029	4.729	1.855
6	0.500	0.222	1.000	0.111	-0.002	0.109	5.800	0.029	5.829	0.634
7	0.500	0.778	0.000	0.000						
13	0.500	0.222	0.000	0.000						
16	0.500	0.222	1.000	0.111	-0.007	0.104	7.000	0.029	7.029	0.733
21	0.500	0.778	0.000	0.000						
64	0.500	0.222	0.000	0.000						
									h _d	4.773

WBL1										
i	P(a _{opp1})	P(a _{CL1})	P(a _{CR1})	P(i)	Adj P(i)	P'(i)	h _{base}	h _{adj}	h _{si}	P'(i)*h _{si}
1	0.542	1.000	0.778	0.422	0.009	0.431	3.900	-0.150	3.750	1.615
2	0.458	1.000	0.778	0.356	0.000	0.356	4.700	-0.150	4.550	1.621
6	0.542	0.000	0.778	0.000						
7	0.542	1.000	0.222	0.120	-0.003	0.117	5.800	-0.150	5.650	0.663
13	0.542	0.000	0.222	0.000						
16	0.458	0.000	0.778	0.000						
21	0.458	1.000	0.222	0.102	-0.006	0.096	7.000	-0.150	6.850	0.655
64	0.458	0.000	0.222	0.000						
									h _d	4.555

AWSC - UNSIGNALIZED INTERSECTIONS WORKSHEET								
Worksheet 5								
General Information								
Project Description <u>Example Problem 4</u>								
Capacity and Level of Service								
	EB		WB		NB		SB	
	L1	L2	L1	L2	L1	L2	L1	L2
Total lane flow rate (veh/h)	350		400				150	
Departure headway, h_d (s)	4.772		4.555				5.393	
Degree of utilization, x	0.464		0.506				0.225	
Move-up time, m (s)	2.00		2.00				2.00	
Service time, t_s (s)	2.772		2.555				3.393	
Capacity (veh/h)	745		765				610	
Delay (s) (Equation 17-55)	11.8		12.1				9.9	
Level of service (Exhibit 17-22)	B		B				A	
Delay, approach (s/veh)	11.8		12.1				9.9	
Level of service, approach	B		B				A	
Delay, intersection (s/veh)	11.7							
Level of service, intersection	B							

EXAMPLE PROBLEM 5

The Intersection An AWSC intersection at four-lane streets. Both right-turn and left-turn lanes are shared.

The Question What are the delay and level of service?

The Facts

- √ Two four-lane urban streets, and
- √ No heavy vehicles.

Comments The use of spreadsheet software is recommended because of the repetitive computations required. The degree of utilization, x , computed in each iteration is used to determine the departure headway of the next iteration. Slight differences in estimated headways may result from rounding differences in manual (handheld calculator) computations or from rounding differences between manual and software computations.

Outline to Solution The steps below show the northbound approach calculations only. Calculations for other approaches are shown on the worksheets.

Steps

<p>1. Data input and volume adjustments.</p>	<p>Worksheets 1 and 2</p> <p>Hourly flow rate = $\frac{\text{Volume}}{\text{PHF}}$</p> <p>NB lane = $\frac{100}{1.00} = 100 \text{ veh/h}$</p>
<p>2. Saturation headway adjustment factor (use Equation 17-56).</p>	<p>Worksheet 3</p> <p>$h_{adj} = h_{LT-adj} P_{LT} + h_{RT-adj} P_{RT} + h_{HV-adj} P_{HV}$</p> <p>NB Lane 1 $h_{adj} = 0.400(0.5) + 0 + 0 = 0.200$</p>
<p>3. Departure headway, service time, probability states, and saturation headway.</p> <p>Probability of each case-conflict combination (use Equation 17-58 and Exhibit 17-34).</p> <p>Probability of degree-of-conflict cases (use Equations 17-59 through 17-63).</p> <p>Probability adjustment factors (use Equations 17-64 through 17-68).</p> <p>Adjusted probability (use Equation 17-69).</p> <p>Saturation headway.</p> <p>Departure headway (use Equation 17-54).</p>	<p>Worksheets 4a and 4b</p> <p>This intersection has four approaches, and each approach has two lanes. In total, eight worksheets are needed for each iteration.</p> <p>$P(i) = \prod_j P(a_j)$</p> <p>$P(1) = P(a_{O1}) P(a_{O2}) P(a_{CL1}) P(a_{CL2}) P(a_{CR1}) P(a_{CR2})$</p> <p>$P(1) = (0.778)(0.778)(0.800)(0.800) (0.778)(0.778) = 0.234$</p> <p>$P(C_1) = P(1) = 0.234$</p> <p>$AdjP(1) = \alpha [P(C_2) + 2P(C_3) + 3P(C_4) + 4P(C_5)]/1$</p> <p>$AdjP(1) = 0.01[0.153 + 2(0.286) + 3(0.272) + 4(0.052)]/1 = 0.018$</p> <p>$P'(i) = P(i) + AdjP(i)$</p> <p>$P'(1) = 0.234 + 0.018 = 0.252$</p> <p>NB Lane 1 $h_{si} = h_{adj} + h_{base}$</p> <p>$h_{si} = 0.200 + 4.5 = 4.700$</p> <p>NB Lane 1 $h_d = \sum_{i=1}^{64} P'(i) h_{si} = 6.435$</p>

<p>3. (continued) Repeat the process until the change in headways between two successive iterations is less than 0.100 s.</p>	
<p>4. Service time and capacity (use Equation 17-53). Capacity is determined by increasing the subject lane volume while holding other volumes constant. Capacity is reached when $x = 1.000$. Control delay and LOS (use Equation 17-55 and Exhibit 17-19). The approach delay is the weighted average of lane delays, while the intersection delay is the weighted average of approach delays.</p>	<p>$t_s = h_d - m$ NB Lane 1 $s = 8.686 - 2.30 = 6.386$ s</p> <p>$d = t_s + 900T[\dots] + 5$ NB Lane 1 $d = 6.41 + 900(0.25)[\dots] + 5 = 23.9$ s, LOS C</p>

Example Problem 5

AWSC - UNSIGNALIZED INTERSECTIONS WORKSHEET

Worksheet 1

General Information		Site Information	
Analyst	JMS	Intersection	Eighth/Sixteenth
Agency or Company	CEI	Jurisdiction	Latah County
Date Performed	5/21/99	Analysis Year	1999
Analysis Time Period	AM Peak		

Geometrics and Movements

Data Required:
Vehicle volumes by movement
Proportion of heavy vehicles

Length of study period = 0.25 h

Worksheet 2

Volume Adjustments and Lane Assignments

Approach		Lane 1			Lane 2			Geometry Group (Exhibit 17-32)
		LT	TH	RT	LT	TH	RT	
EB	Volume (veh/h)	100	125			175	50	5
	PHF	1.00			1.00			
	% Heavy vehicle	0	0			0	0	
	Flow rate (veh/h)	100	125			175	50	
WB	Volume (veh/h)	100	150			150	100	5
	PHF	1.00			1.00			
	% Heavy vehicle	0	0			0	0	
	Flow rate (veh/h)	100	150			150	100	
NB	Volume (veh/h)	100	150			200	50	5
	PHF	1.00			1.00			
	% Heavy vehicle	0	0			0	0	
	Flow rate (veh/h)	100	150			200	50	
SB	Volume (veh/h)	50	200			100	150	5
	PHF	1.00			1.00			
	% Heavy vehicle	0	0			0	0	
	Flow rate (veh/h)	50	200			100	150	

AWSC - UNSIGNALIZED INTERSECTIONS WORKSHEET								
Worksheet 3								
General Information								
Project Description <u>Example Problem 5</u>								
Saturation Headways								
	EB		WB		NB		SB	
	L1	L2	L1	L2	L1	L2	L1	L2
Total lane flow rate	225	225	250	250	250	250	250	250
Left-turn flow rate in lane	100	0	100	0	100	0	50	0
Right-turn flow rate in lane	0	50	0	100	0	50	0	150
Proportion LT in lane	0.444	0.000	0.400	0.000	0.400	0.000	0.200	0.000
Proportion RT in lane	0.000	0.222	0.000	0.400	0.000	0.200	0.000	0.600
Proportion HV in lane	0	0	0	0	0	0	0	0
h_{LT-adj} (Exhibit 17-33)	0.5	0.5	0.5	0.5	0.5	0.5	0.5	0.5
h_{RT-adj} (Exhibit 17-33)	-0.7	-0.7	-0.7	-0.7	-0.7	-0.7	-0.7	-0.7
h_{HV-adj} (Exhibit 17-33)	1.7	1.7	1.7	1.7	1.7	1.7	1.7	1.7
h_{adj} (Equation 17-56)	0.222	-0.155	0.200	-0.280	0.2000	-0.140	0.100	-0.420
Worksheet 4a								
Departure Headway								
	EB		WB		NB		SB	
	L1	L2	L1	L2	L1	L2	L1	L2
Total lane flow rate	225	225	250	250	250	250	250	250
h_0 , initial value (s)	3.2	3.2	3.2	3.2	3.2	3.2	3.2	3.2
x , initial value (Equation 17-57)	0.200	0.200	0.222	0.222	0.222	0.222	0.222	0.222
h_0 , Iteration 1	6.521	6.144	6.461	5.954	6.435	6.094	6.334	5.814
h_0 , difference	3.321	2.944	3.261	2.754	3.235	2.894	3.134	2.614
h_0 , Iteration 2	7.868	7.491	7.846	7.366	7.846	7.506	7.746	7.226
h_0 , difference	1.347	1.347	1.385	1.412	1.411	1.412	1.412	1.412
h_0 , Iteration 3	8.424	8.047	8.402	7.922	8.402	8.062	8.302	7.782
h_0 , difference	0.556	0.556	0.556	0.556	0.556	0.556	0.556	0.556
h_0 , Iteration 4	8.632	8.255	8.61	8.13	8.610	8.270	8.510	7.990
h_0 , difference	0.208	0.208	0.208	0.208	0.208	0.208	0.208	0.208
h_0 , Iteration 5	8.708	8.331	8.686	8.206	8.686	8.346	8.586	8.066
h_0 , difference	0.076	0.076	0.076	0.076	0.076	0.076	0.076	0.076
Convergence?	Y	Y	Y	Y	Y	Y	Y	Y
h_0 , final	8.708	8.331	8.686	8.206	8.686	8.346	8.586	8.066
x , final	0.544	0.521	0.603	0.570	0.603	0.580	0.596	0.560

Example Problem 5

EBL1 - ITERATION 1

	P(a _{ol1})	P(a _{ol2})	P(a _{cl1})	P(a _{cl2})	P(a _{cr1})	P(a _{cr2})	P(i)	Adj P(i)	P'(i)	h _{base}	h _{adj}	h _{si}	P'(i)*h _{si}
1	0.778	0.778	0.778	0.778	0.778	0.778	0.221757	0.018178	0.239935	4.5	0.222	4.722	1.132973
2	0.222	0.778	0.778	0.778	0.778	0.778	0.063278	0.002983	0.066261	5.0	0.222	5.222	0.346014
3	0.778	0.222	0.778	0.778	0.778	0.778	0.063278	0.002983	0.066261	5.0	0.222	5.222	0.346014
4	0.222	0.222	0.778	0.778	0.778	0.778	0.018056	0.002983	0.021039	6.2	0.222	6.422	0.135114
5	0.778	0.778	0.778	0.222	0.778	0.778	0.063278	-0.000770	0.062508	6.4	0.222	6.622	0.413929
6	0.778	0.778	0.222	0.778	0.778	0.778	0.063278	-0.000770	0.062508	6.4	0.222	6.622	0.413929
7	0.778	0.778	0.778	0.778	0.222	0.778	0.063278	-0.000770	0.062508	6.4	0.222	6.622	0.413929
8	0.778	0.778	0.778	0.778	0.778	0.222	0.063278	-0.000770	0.062508	6.4	0.222	6.622	0.413929
9	0.778	0.778	0.222	0.222	0.778	0.778	0.018056	-0.000770	0.017287	7.2	0.222	7.422	0.128300
10	0.778	0.778	0.778	0.778	0.222	0.222	0.018056	-0.000770	0.017287	7.2	0.222	7.422	0.128300
11	0.778	0.778	0.778	0.222	0.778	0.222	0.018056	-0.000606	0.017450	7.6	0.222	7.822	0.136495
12	0.778	0.778	0.222	0.778	0.778	0.222	0.018056	-0.000606	0.017450	7.6	0.222	7.822	0.136495
13	0.778	0.778	0.222	0.778	0.222	0.778	0.018056	-0.000606	0.017450	7.6	0.222	7.822	0.136495
14	0.778	0.778	0.778	0.222	0.222	0.778	0.018056	-0.000606	0.017450	7.6	0.222	7.822	0.136495
15	0.778	0.222	0.778	0.222	0.778	0.778	0.018056	-0.000606	0.017450	7.6	0.222	7.822	0.136495
16	0.222	0.778	0.222	0.778	0.778	0.778	0.018056	-0.000606	0.017450	7.6	0.222	7.822	0.136495
17	0.778	0.222	0.778	0.778	0.222	0.778	0.018056	-0.000606	0.017450	7.6	0.222	7.822	0.136495
18	0.222	0.778	0.778	0.222	0.778	0.778	0.018056	-0.000606	0.017450	7.6	0.222	7.822	0.136495
19	0.778	0.222	0.222	0.778	0.778	0.778	0.018056	-0.000606	0.017450	7.6	0.222	7.822	0.136495
20	0.778	0.222	0.778	0.778	0.778	0.222	0.018056	-0.000606	0.017450	7.6	0.222	7.822	0.136495
21	0.222	0.778	0.778	0.778	0.222	0.778	0.018056	-0.000606	0.017450	7.6	0.222	7.822	0.136495
22	0.222	0.778	0.778	0.778	0.778	0.222	0.018056	-0.000606	0.017450	7.6	0.222	7.822	0.136495
23	0.778	0.778	0.778	0.222	0.222	0.222	0.005152	-0.000606	0.004546	7.8	0.222	8.022	0.036471
24	0.778	0.778	0.222	0.222	0.778	0.222	0.005152	-0.000606	0.004546	7.8	0.222	8.022	0.036471
25	0.778	0.778	0.222	0.222	0.222	0.778	0.005152	-0.000606	0.004546	7.8	0.222	8.022	0.036471
26	0.222	0.778	0.222	0.222	0.778	0.778	0.005152	-0.000606	0.004546	7.8	0.222	8.022	0.036471
27	0.222	0.222	0.222	0.778	0.778	0.778	0.005152	-0.000606	0.004546	7.8	0.222	8.022	0.036471
28	0.222	0.222	0.778	0.778	0.222	0.778	0.005152	-0.000606	0.004546	7.8	0.222	8.022	0.036471
29	0.222	0.222	0.778	0.778	0.778	0.222	0.005152	-0.000606	0.004546	7.8	0.222	8.022	0.036471
30	0.778	0.222	0.222	0.222	0.778	0.778	0.005152	-0.000606	0.004546	7.8	0.222	8.022	0.036471
31	0.222	0.778	0.778	0.778	0.222	0.222	0.005152	-0.000606	0.004546	7.8	0.222	8.022	0.036471
32	0.778	0.778	0.222	0.778	0.222	0.222	0.005152	-0.000606	0.004546	7.8	0.222	8.022	0.036471
33	0.222	0.222	0.778	0.222	0.778	0.778	0.005152	-0.000606	0.004546	7.8	0.222	8.022	0.036471
34	0.778	0.222	0.778	0.778	0.222	0.222	0.005152	-0.000606	0.004546	7.8	0.222	8.022	0.036471
35	0.222	0.222	0.778	0.778	0.222	0.222	0.001470	-0.000606	0.000864	9.0	0.222	9.222	0.007970
36	0.778	0.778	0.222	0.222	0.222	0.222	0.001470	-0.000606	0.000864	9.0	0.222	9.222	0.007970
37	0.222	0.222	0.222	0.222	0.778	0.778	0.001470	-0.000606	0.000864	9.0	0.222	9.222	0.007970
38	0.778	0.222	0.778	0.222	0.778	0.222	0.005152	-0.000228	0.004924	9.7	0.222	9.922	0.048861
39	0.222	0.778	0.778	0.222	0.222	0.778	0.005152	-0.000228	0.004924	9.7	0.222	9.922	0.048861
40	0.778	0.222	0.222	0.778	0.222	0.778	0.005152	-0.000228	0.004924	9.7	0.222	9.922	0.048861
41	0.778	0.222	0.778	0.222	0.222	0.778	0.005152	-0.000228	0.004924	9.7	0.222	9.922	0.048861
42	0.778	0.222	0.222	0.778	0.778	0.222	0.005152	-0.000228	0.004924	9.7	0.222	9.922	0.048861
43	0.222	0.778	0.222	0.778	0.778	0.222	0.005152	-0.000228	0.004924	9.7	0.222	9.922	0.048861
44	0.222	0.778	0.778	0.222	0.778	0.222	0.005152	-0.000228	0.004924	9.7	0.222	9.922	0.048861
45	0.222	0.778	0.222	0.778	0.222	0.778	0.005152	-0.000228	0.004924	9.7	0.222	9.922	0.048861
46	0.222	0.778	0.778	0.222	0.222	0.222	0.001470	-0.000228	0.001242	9.7	0.222	9.922	0.012327
47	0.778	0.222	0.222	0.222	0.222	0.778	0.001470	-0.000228	0.001242	9.7	0.222	9.922	0.012327
48	0.778	0.222	0.222	0.222	0.778	0.222	0.001470	-0.000228	0.001242	9.7	0.222	9.922	0.012327
49	0.222	0.778	0.222	0.778	0.222	0.222	0.001470	-0.000228	0.001242	9.7	0.222	9.922	0.012327
50	0.222	0.778	0.222	0.222	0.222	0.778	0.001470	-0.000228	0.001242	9.7	0.222	9.922	0.012327
51	0.778	0.222	0.778	0.222	0.222	0.222	0.001470	-0.000228	0.001242	9.7	0.222	9.922	0.012327
52	0.222	0.222	0.222	0.778	0.778	0.222	0.001470	-0.000228	0.001242	9.7	0.222	9.922	0.012327
53	0.222	0.778	0.222	0.222	0.778	0.222	0.001470	-0.000228	0.001242	9.7	0.222	9.922	0.012327
54	0.778	0.222	0.222	0.778	0.222	0.222	0.001470	-0.000228	0.001242	9.7	0.222	9.922	0.012327
55	0.222	0.222	0.778	0.222	0.222	0.778	0.001470	-0.000228	0.001242	9.7	0.222	9.922	0.012327
56	0.222	0.222	0.778	0.222	0.778	0.222	0.001470	-0.000228	0.001242	9.7	0.222	9.922	0.012327
57	0.222	0.222	0.222	0.778	0.222	0.778	0.001470	-0.000228	0.001242	9.7	0.222	9.922	0.012327
58	0.222	0.778	0.222	0.222	0.222	0.222	0.000420	-0.000228	0.000192	10.0	0.222	10.222	0.001960
59	0.222	0.222	0.778	0.222	0.222	0.222	0.000420	-0.000228	0.000192	10.0	0.222	10.222	0.001960
60	0.222	0.222	0.222	0.778	0.222	0.222	0.000420	-0.000228	0.000192	10.0	0.222	10.222	0.001960
61	0.778	0.222	0.222	0.222	0.222	0.222	0.000420	-0.000228	0.000192	10.0	0.222	10.222	0.001960
62	0.222	0.222	0.222	0.222	0.222	0.778	0.000420	-0.000228	0.000192	10.0	0.222	10.222	0.001960
63	0.222	0.222	0.222	0.222	0.778	0.222	0.000420	-0.000228	0.000192	10.0	0.222	10.222	0.001960
64	0.222	0.222	0.222	0.222	0.222	0.222	0.000120	-0.000228	-0.000108	11.5	0.222	11.722	-0.001267
													6.521244

EBL2 - ITERATION 1

Example Problem 5

	P(a _{ol1})	P(a _{ol2})	P(a _{cl1})	P(a _{cl2})	P(a _{CR1})	P(a _{CR2})	P(i)	Adj P(i)	P'(i)	h _{base}	h _{adj}	h _{sl}	P'(i)*h _{sl}
1	0.778	0.778	0.778	0.778	0.778	0.778	0.221757	0.018178	0.239935	4.5	-0.155	4.345	1.042517
2	0.222	0.778	0.778	0.778	0.778	0.778	0.063278	0.002983	0.066261	5.0	-0.155	4.845	0.321034
3	0.778	0.222	0.778	0.778	0.778	0.778	0.063278	0.002983	0.066261	5.0	-0.155	4.845	0.321034
4	0.222	0.222	0.778	0.778	0.778	0.778	0.018056	0.002983	0.021039	6.2	-0.155	6.045	0.127182
5	0.778	0.778	0.778	0.222	0.778	0.778	0.063278	-0.000770	0.062508	6.4	-0.155	6.245	0.390363
6	0.778	0.778	0.222	0.778	0.778	0.778	0.063278	-0.000770	0.062508	6.4	-0.155	6.245	0.390363
7	0.778	0.778	0.778	0.778	0.222	0.778	0.063278	-0.000770	0.062508	6.4	-0.155	6.245	0.390363
8	0.778	0.778	0.778	0.778	0.778	0.222	0.063278	-0.000770	0.062508	6.4	-0.155	6.245	0.390363
9	0.778	0.778	0.222	0.222	0.778	0.778	0.018056	-0.000770	0.017287	7.2	-0.155	7.045	0.121783
10	0.778	0.778	0.778	0.778	0.222	0.222	0.018056	-0.000770	0.017287	7.2	-0.155	7.045	0.121783
11	0.778	0.778	0.778	0.222	0.778	0.222	0.018056	-0.000606	0.017450	7.6	-0.155	7.445	0.129917
12	0.778	0.778	0.222	0.778	0.778	0.222	0.018056	-0.000606	0.017450	7.6	-0.155	7.445	0.129917
13	0.778	0.778	0.222	0.778	0.222	0.778	0.018056	-0.000606	0.017450	7.6	-0.155	7.445	0.129917
14	0.778	0.778	0.778	0.222	0.222	0.778	0.018056	-0.000606	0.017450	7.6	-0.155	7.445	0.129917
15	0.778	0.222	0.778	0.222	0.778	0.778	0.018056	-0.000606	0.017450	7.6	-0.155	7.445	0.129917
16	0.222	0.778	0.222	0.778	0.778	0.778	0.018056	-0.000606	0.017450	7.6	-0.155	7.445	0.129917
17	0.778	0.222	0.778	0.778	0.222	0.778	0.018056	-0.000606	0.017450	7.6	-0.155	7.445	0.129917
18	0.222	0.778	0.778	0.222	0.778	0.778	0.018056	-0.000606	0.017450	7.6	-0.155	7.445	0.129917
19	0.778	0.222	0.222	0.778	0.778	0.778	0.018056	-0.000606	0.017450	7.6	-0.155	7.445	0.129917
20	0.778	0.222	0.778	0.778	0.778	0.222	0.018056	-0.000606	0.017450	7.6	-0.155	7.445	0.129917
21	0.222	0.778	0.778	0.778	0.222	0.778	0.018056	-0.000606	0.017450	7.6	-0.155	7.445	0.129917
22	0.222	0.778	0.778	0.778	0.778	0.222	0.018056	-0.000606	0.017450	7.6	-0.155	7.445	0.129917
23	0.778	0.778	0.778	0.222	0.222	0.222	0.005152	-0.000606	0.004546	7.8	-0.155	7.645	0.034757
24	0.778	0.778	0.222	0.222	0.778	0.222	0.005152	-0.000606	0.004546	7.8	-0.155	7.645	0.034757
25	0.778	0.778	0.222	0.222	0.222	0.778	0.005152	-0.000606	0.004546	7.8	-0.155	7.645	0.034757
26	0.222	0.778	0.222	0.222	0.778	0.778	0.005152	-0.000606	0.004546	7.8	-0.155	7.645	0.034757
27	0.222	0.222	0.222	0.778	0.778	0.778	0.005152	-0.000606	0.004546	7.8	-0.155	7.645	0.034757
28	0.222	0.222	0.778	0.778	0.222	0.778	0.005152	-0.000606	0.004546	7.8	-0.155	7.645	0.034757
29	0.222	0.222	0.778	0.778	0.778	0.222	0.005152	-0.000606	0.004546	7.8	-0.155	7.645	0.034757
30	0.778	0.222	0.222	0.222	0.778	0.778	0.005152	-0.000606	0.004546	7.8	-0.155	7.645	0.034757
31	0.222	0.778	0.778	0.778	0.222	0.222	0.005152	-0.000606	0.004546	7.8	-0.155	7.645	0.034757
32	0.778	0.778	0.222	0.778	0.222	0.222	0.005152	-0.000606	0.004546	7.8	-0.155	7.645	0.034757
33	0.222	0.222	0.778	0.222	0.778	0.778	0.005152	-0.000606	0.004546	7.8	-0.155	7.645	0.034757
34	0.778	0.222	0.778	0.778	0.222	0.222	0.005152	-0.000606	0.004546	7.8	-0.155	7.645	0.034757
35	0.222	0.222	0.778	0.778	0.222	0.222	0.001470	-0.000606	0.000864	9.0	-0.155	8.845	0.007644
36	0.778	0.778	0.222	0.222	0.222	0.222	0.001470	-0.000606	0.000864	9.0	-0.155	8.845	0.007644
37	0.222	0.222	0.222	0.222	0.778	0.778	0.001470	-0.000606	0.000864	9.0	-0.155	8.845	0.007644
38	0.778	0.222	0.778	0.222	0.778	0.222	0.005152	-0.000228	0.004924	9.7	-0.155	9.545	0.047004
39	0.222	0.778	0.778	0.222	0.222	0.778	0.005152	-0.000228	0.004924	9.7	-0.155	9.545	0.047004
40	0.778	0.222	0.222	0.778	0.222	0.778	0.005152	-0.000228	0.004924	9.7	-0.155	9.545	0.047004
41	0.778	0.222	0.778	0.222	0.222	0.778	0.005152	-0.000228	0.004924	9.7	-0.155	9.545	0.047004
42	0.778	0.222	0.222	0.778	0.778	0.222	0.005152	-0.000228	0.004924	9.7	-0.155	9.545	0.047004
43	0.222	0.778	0.222	0.778	0.778	0.222	0.005152	-0.000228	0.004924	9.7	-0.155	9.545	0.047004
44	0.222	0.778	0.778	0.222	0.778	0.222	0.005152	-0.000228	0.004924	9.7	-0.155	9.545	0.047004
45	0.222	0.778	0.222	0.778	0.222	0.778	0.005152	-0.000228	0.004924	9.7	-0.155	9.545	0.047004
46	0.222	0.778	0.778	0.222	0.222	0.222	0.001470	-0.000228	0.001242	9.7	-0.155	9.545	0.011859
47	0.778	0.222	0.222	0.222	0.222	0.778	0.001470	-0.000228	0.001242	9.7	-0.155	9.545	0.011859
48	0.778	0.222	0.222	0.222	0.778	0.222	0.001470	-0.000228	0.001242	9.7	-0.155	9.545	0.011859
49	0.222	0.778	0.222	0.778	0.222	0.222	0.001470	-0.000228	0.001242	9.7	-0.155	9.545	0.011859
50	0.222	0.778	0.222	0.222	0.222	0.778	0.001470	-0.000228	0.001242	9.7	-0.155	9.545	0.011859
51	0.778	0.222	0.778	0.222	0.222	0.222	0.001470	-0.000228	0.001242	9.7	-0.155	9.545	0.011859
52	0.222	0.222	0.222	0.778	0.778	0.222	0.001470	-0.000228	0.001242	9.7	-0.155	9.545	0.011859
53	0.222	0.778	0.222	0.222	0.778	0.222	0.001470	-0.000228	0.001242	9.7	-0.155	9.545	0.011859
54	0.778	0.222	0.222	0.778	0.222	0.222	0.001470	-0.000228	0.001242	9.7	-0.155	9.545	0.011859
55	0.222	0.222	0.778	0.222	0.222	0.778	0.001470	-0.000228	0.001242	9.7	-0.155	9.545	0.011859
56	0.222	0.222	0.778	0.222	0.778	0.222	0.001470	-0.000228	0.001242	9.7	-0.155	9.545	0.011859
57	0.222	0.222	0.222	0.778	0.222	0.778	0.001470	-0.000228	0.001242	9.7	-0.155	9.545	0.011859
58	0.222	0.778	0.222	0.222	0.222	0.222	0.000420	-0.000228	0.000192	10.0	-0.155	9.845	0.001888
59	0.222	0.222	0.778	0.222	0.222	0.222	0.000420	-0.000228	0.000192	10.0	-0.155	9.845	0.001888
60	0.222	0.222	0.222	0.778	0.222	0.222	0.000420	-0.000228	0.000192	10.0	-0.155	9.845	0.001888
61	0.778	0.222	0.222	0.222	0.222	0.222	0.000420	-0.000228	0.000192	10.0	-0.155	9.845	0.001888
62	0.222	0.222	0.222	0.222	0.222	0.778	0.000420	-0.000228	0.000192	10.0	-0.155	9.845	0.001888
63	0.222	0.222	0.222	0.222	0.778	0.222	0.000420	-0.000228	0.000192	10.0	-0.155	9.845	0.001888
64	0.222	0.222	0.222	0.222	0.222	0.222	0.000120	-0.000228	-0.000108	11.5	-0.155	11.345	-0.001226 6.144244

Example Problem 5

WBL1 - ITERATION 1

	P(a _{ol1})	P(a _{ol2})	P(a _{cl1})	P(a _{cl2})	P(a _{cr1})	P(a _{cr2})	P(i)	Adj P(i)	P'(i)	h _{base}	h _{adj}	h _{si}	P'(i)*h _{si}
1	0.8	0.8	0.778	0.778	0.778	0.778	0.234476	0.017831	0.252307	4.5	0.200	4.700	1.185841
2	0.2	0.8	0.778	0.778	0.778	0.778	0.058619	0.002952	0.061571	5.0	0.200	5.200	0.320170
3	0.8	0.2	0.778	0.778	0.778	0.778	0.058619	0.002952	0.061571	5.0	0.200	5.200	0.320170
4	0.2	0.2	0.778	0.778	0.778	0.778	0.014655	0.002952	0.017607	6.2	0.200	6.400	0.112684
5	0.8	0.8	0.778	0.222	0.778	0.778	0.066907	-0.000889	0.066018	6.4	0.200	6.600	0.435718
6	0.8	0.8	0.222	0.778	0.778	0.778	0.066907	-0.000889	0.066018	6.4	0.200	6.600	0.435718
7	0.8	0.8	0.778	0.778	0.222	0.778	0.066907	-0.000889	0.066018	6.4	0.200	6.600	0.435718
8	0.8	0.8	0.778	0.778	0.778	0.222	0.066907	-0.000889	0.066018	6.4	0.200	6.600	0.435718
9	0.8	0.8	0.222	0.222	0.778	0.778	0.019092	-0.000889	0.018203	7.2	0.200	7.400	0.134699
10	0.8	0.8	0.778	0.778	0.222	0.222	0.019092	-0.000889	0.018203	7.2	0.200	7.400	0.134699
11	0.8	0.8	0.778	0.222	0.778	0.222	0.019092	-0.000583	0.018509	7.6	0.200	7.800	0.144367
12	0.8	0.8	0.222	0.778	0.778	0.222	0.019092	-0.000583	0.018509	7.6	0.200	7.800	0.144367
13	0.8	0.8	0.222	0.778	0.222	0.778	0.019092	-0.000583	0.018509	7.6	0.200	7.800	0.144367
14	0.8	0.8	0.778	0.222	0.222	0.778	0.019092	-0.000583	0.018509	7.6	0.200	7.800	0.144367
15	0.8	0.2	0.778	0.222	0.778	0.778	0.016727	-0.000583	0.016144	7.6	0.200	7.800	0.125921
16	0.2	0.8	0.222	0.778	0.778	0.778	0.016727	-0.000583	0.016144	7.6	0.200	7.800	0.125921
17	0.8	0.2	0.778	0.778	0.222	0.778	0.016727	-0.000583	0.016144	7.6	0.200	7.800	0.125921
18	0.2	0.8	0.778	0.222	0.778	0.778	0.016727	-0.000583	0.016144	7.6	0.200	7.800	0.125921
19	0.8	0.2	0.222	0.778	0.778	0.778	0.016727	-0.000583	0.016144	7.6	0.200	7.800	0.125921
20	0.8	0.2	0.778	0.778	0.778	0.222	0.016727	-0.000583	0.016144	7.6	0.200	7.800	0.125921
21	0.2	0.8	0.778	0.778	0.222	0.778	0.016727	-0.000583	0.016144	7.6	0.200	7.800	0.125921
22	0.2	0.8	0.778	0.778	0.778	0.222	0.016727	-0.000583	0.016144	7.6	0.200	7.800	0.125921
23	0.8	0.8	0.778	0.222	0.222	0.222	0.005448	-0.000583	0.004865	7.8	0.200	8.000	0.038918
24	0.8	0.8	0.222	0.222	0.778	0.222	0.005448	-0.000583	0.004865	7.8	0.200	8.000	0.038918
25	0.8	0.8	0.222	0.222	0.222	0.778	0.005448	-0.000583	0.004865	7.8	0.200	8.000	0.038918
26	0.2	0.8	0.222	0.222	0.778	0.778	0.004773	-0.000583	0.004190	7.8	0.200	8.000	0.033519
27	0.2	0.2	0.222	0.778	0.778	0.778	0.004182	-0.000583	0.003599	7.8	0.200	8.000	0.028789
28	0.2	0.2	0.778	0.778	0.778	0.222	0.004182	-0.000583	0.003599	7.8	0.200	8.000	0.028789
29	0.2	0.2	0.778	0.778	0.778	0.222	0.004182	-0.000583	0.003599	7.8	0.200	8.000	0.028789
30	0.8	0.2	0.222	0.222	0.778	0.778	0.004773	-0.000583	0.004190	7.8	0.200	8.000	0.033519
31	0.2	0.8	0.778	0.778	0.222	0.222	0.004773	-0.000583	0.004190	7.8	0.200	8.000	0.033519
32	0.8	0.8	0.222	0.778	0.222	0.222	0.005448	-0.000583	0.004865	7.8	0.200	8.000	0.038918
33	0.2	0.2	0.778	0.222	0.778	0.778	0.004182	-0.000583	0.003599	7.8	0.200	8.000	0.028789
34	0.8	0.2	0.778	0.778	0.222	0.222	0.004773	-0.000583	0.004190	7.8	0.200	8.000	0.033519
35	0.2	0.2	0.778	0.778	0.222	0.222	0.001193	-0.000583	0.000610	9.0	0.200	9.200	0.005613
36	0.8	0.8	0.222	0.222	0.222	0.222	0.001555	-0.000583	0.000971	9.0	0.200	9.200	0.008937
37	0.2	0.2	0.222	0.222	0.778	0.778	0.001193	-0.000583	0.000610	9.0	0.200	9.200	0.005613
38	0.8	0.2	0.778	0.222	0.778	0.222	0.004773	-0.000208	0.004565	9.7	0.200	9.900	0.045195
39	0.2	0.8	0.778	0.222	0.222	0.778	0.004773	-0.000208	0.004565	9.7	0.200	9.900	0.045195
40	0.8	0.2	0.222	0.778	0.222	0.778	0.004773	-0.000208	0.004565	9.7	0.200	9.900	0.045195
41	0.8	0.2	0.778	0.222	0.222	0.778	0.004773	-0.000208	0.004565	9.7	0.200	9.900	0.045195
42	0.8	0.2	0.222	0.778	0.778	0.222	0.004773	-0.000208	0.004565	9.7	0.200	9.900	0.045195
43	0.2	0.8	0.222	0.778	0.778	0.222	0.004773	-0.000208	0.004565	9.7	0.200	9.900	0.045195
44	0.2	0.8	0.778	0.222	0.778	0.222	0.004773	-0.000208	0.004565	9.7	0.200	9.900	0.045195
45	0.2	0.8	0.222	0.778	0.222	0.778	0.004773	-0.000208	0.004565	9.7	0.200	9.900	0.045195
46	0.2	0.8	0.778	0.222	0.222	0.222	0.001362	-0.000208	0.001154	9.7	0.200	9.900	0.011427
47	0.8	0.2	0.222	0.222	0.222	0.778	0.001362	-0.000208	0.001154	9.7	0.200	9.900	0.011427
48	0.8	0.2	0.222	0.222	0.778	0.222	0.001362	-0.000208	0.001154	9.7	0.200	9.900	0.011427
49	0.2	0.8	0.222	0.778	0.222	0.222	0.001362	-0.000208	0.001154	9.7	0.200	9.900	0.011427
50	0.2	0.8	0.222	0.222	0.222	0.778	0.001362	-0.000208	0.001154	9.7	0.200	9.900	0.011427
51	0.8	0.2	0.778	0.222	0.222	0.222	0.001362	-0.000208	0.001154	9.7	0.200	9.900	0.011427
52	0.2	0.2	0.222	0.778	0.778	0.222	0.001193	-0.000208	0.000985	9.7	0.200	9.900	0.009756
53	0.2	0.8	0.222	0.222	0.778	0.222	0.001362	-0.000208	0.001154	9.7	0.200	9.900	0.011427
54	0.8	0.2	0.222	0.778	0.222	0.222	0.001362	-0.000208	0.001154	9.7	0.200	9.900	0.011427
55	0.2	0.2	0.778	0.222	0.222	0.778	0.001193	-0.000208	0.000985	9.7	0.200	9.900	0.009756
56	0.2	0.2	0.778	0.222	0.778	0.222	0.001193	-0.000208	0.000985	9.7	0.200	9.900	0.009756
57	0.2	0.2	0.222	0.778	0.222	0.778	0.001193	-0.000208	0.000985	9.7	0.200	9.900	0.009756
58	0.2	0.8	0.222	0.222	0.222	0.222	0.000389	-0.000208	0.000181	10.0	0.200	10.200	0.001845
59	0.2	0.2	0.778	0.222	0.222	0.222	0.000340	-0.000208	0.000133	10.0	0.200	10.200	0.001354
60	0.2	0.2	0.222	0.778	0.222	0.222	0.000340	-0.000208	0.000133	10.0	0.200	10.200	0.001354
61	0.8	0.2	0.222	0.222	0.222	0.222	0.000389	-0.000208	0.000181	10.0	0.200	10.200	0.001845
62	0.2	0.2	0.222	0.222	0.222	0.778	0.000340	-0.000208	0.000133	10.0	0.200	10.200	0.001354
63	0.2	0.2	0.222	0.222	0.778	0.222	0.000340	-0.000208	0.000133	10.0	0.200	10.200	0.001354
64	0.2	0.2	0.222	0.222	0.222	0.222	0.000097	-0.000208	-0.000111	11.5	0.200	11.700	-0.001294 6.460849

WBL2 - ITERATION 1

Example Problem 5

	P(a _{ol1})	P(a _{ol2})	P(a _{cl1})	P(a _{cl2})	P(a _{cr1})	P(a _{cr2})	P(i)	Adj P(i)	P'(i)	h _{base}	h _{adj}	h _{sl}	P'(i)*h _{sl}
1	0.778	0.778	0.8	0.8	0.778	0.778	0.234476	0.017621	0.252096	4.5	-0.280	4.220	1.063847
2	0.222	0.778	0.8	0.8	0.778	0.778	0.066907	0.002812	0.069719	5.0	-0.280	4.720	0.329074
3	0.778	0.222	0.8	0.8	0.778	0.778	0.066907	0.002812	0.069719	5.0	-0.280	4.720	0.329074
4	0.222	0.222	0.8	0.8	0.778	0.778	0.019092	0.002812	0.021904	6.2	-0.280	5.920	0.129670
5	0.778	0.778	0.8	0.2	0.778	0.778	0.058619	-0.000784	0.057835	6.4	-0.280	6.120	0.353949
6	0.778	0.778	0.2	0.8	0.778	0.778	0.058619	-0.000784	0.057835	6.4	-0.280	6.120	0.353949
7	0.778	0.778	0.8	0.8	0.222	0.778	0.066907	-0.000784	0.066123	6.4	-0.280	6.120	0.404672
8	0.778	0.778	0.8	0.8	0.778	0.222	0.066907	-0.000784	0.066123	6.4	-0.280	6.120	0.404672
9	0.778	0.778	0.2	0.2	0.778	0.778	0.014655	-0.000784	0.013871	7.2	-0.280	6.920	0.095985
10	0.778	0.778	0.8	0.8	0.222	0.222	0.019092	-0.000784	0.018308	7.2	-0.280	6.920	0.126688
11	0.778	0.778	0.8	0.2	0.778	0.222	0.016727	-0.000583	0.016144	7.6	-0.280	7.320	0.118172
12	0.778	0.778	0.2	0.8	0.778	0.222	0.016727	-0.000583	0.016144	7.6	-0.280	7.320	0.118172
13	0.778	0.778	0.2	0.8	0.222	0.778	0.016727	-0.000583	0.016144	7.6	-0.280	7.320	0.118172
14	0.778	0.778	0.8	0.2	0.222	0.778	0.016727	-0.000583	0.016144	7.6	-0.280	7.320	0.118172
15	0.778	0.222	0.8	0.2	0.778	0.778	0.016727	-0.000583	0.016144	7.6	-0.280	7.320	0.118172
16	0.222	0.778	0.2	0.8	0.778	0.778	0.016727	-0.000583	0.016144	7.6	-0.280	7.320	0.118172
17	0.778	0.222	0.8	0.8	0.222	0.778	0.019092	-0.000583	0.018509	7.6	-0.280	7.320	0.135483
18	0.222	0.778	0.8	0.2	0.778	0.778	0.016727	-0.000583	0.016144	7.6	-0.280	7.320	0.118172
19	0.778	0.222	0.2	0.8	0.778	0.778	0.016727	-0.000583	0.016144	7.6	-0.280	7.320	0.118172
20	0.778	0.222	0.8	0.8	0.778	0.222	0.019092	-0.000583	0.018509	7.6	-0.280	7.320	0.135483
21	0.222	0.778	0.8	0.8	0.222	0.778	0.019092	-0.000583	0.018509	7.6	-0.280	7.320	0.135483
22	0.222	0.778	0.8	0.8	0.778	0.222	0.019092	-0.000583	0.018509	7.6	-0.280	7.320	0.135483
23	0.778	0.778	0.8	0.2	0.222	0.222	0.004773	-0.000583	0.004190	7.8	-0.280	7.520	0.031508
24	0.778	0.778	0.2	0.2	0.778	0.222	0.004182	-0.000583	0.003599	7.8	-0.280	7.520	0.027062
25	0.778	0.778	0.2	0.2	0.222	0.778	0.004182	-0.000583	0.003599	7.8	-0.280	7.520	0.027062
26	0.222	0.778	0.2	0.2	0.778	0.778	0.004182	-0.000583	0.003599	7.8	-0.280	7.520	0.027062
27	0.222	0.222	0.2	0.8	0.778	0.778	0.004773	-0.000583	0.004190	7.8	-0.280	7.520	0.031508
28	0.222	0.222	0.8	0.8	0.222	0.778	0.005448	-0.000583	0.004865	7.8	-0.280	7.520	0.036582
29	0.222	0.222	0.8	0.8	0.778	0.222	0.005448	-0.000583	0.004865	7.8	-0.280	7.520	0.036582
30	0.778	0.222	0.2	0.2	0.778	0.778	0.004182	-0.000583	0.003599	7.8	-0.280	7.520	0.027062
31	0.222	0.778	0.8	0.8	0.222	0.222	0.005448	-0.000583	0.004865	7.8	-0.280	7.520	0.036582
32	0.778	0.778	0.2	0.8	0.222	0.222	0.004773	-0.000583	0.004190	7.8	-0.280	7.520	0.031508
33	0.222	0.222	0.8	0.2	0.778	0.778	0.004773	-0.000583	0.004190	7.8	-0.280	7.520	0.031508
34	0.778	0.222	0.8	0.8	0.222	0.222	0.005448	-0.000583	0.004865	7.8	-0.280	7.520	0.036582
35	0.222	0.222	0.8	0.8	0.222	0.222	0.001555	-0.000583	0.000971	9.0	-0.280	8.720	0.008471
36	0.778	0.778	0.2	0.2	0.222	0.222	0.001193	-0.000583	0.000610	9.0	-0.280	8.720	0.005321
37	0.222	0.222	0.2	0.2	0.778	0.778	0.001193	-0.000583	0.000610	9.0	-0.280	8.720	0.005321
38	0.778	0.222	0.8	0.2	0.778	0.222	0.004773	-0.000208	0.004565	9.7	-0.280	9.420	0.043004
39	0.222	0.778	0.8	0.2	0.222	0.778	0.004773	-0.000208	0.004565	9.7	-0.280	9.420	0.043004
40	0.778	0.222	0.2	0.8	0.222	0.778	0.004773	-0.000208	0.004565	9.7	-0.280	9.420	0.043004
41	0.778	0.222	0.8	0.2	0.222	0.778	0.004773	-0.000208	0.004565	9.7	-0.280	9.420	0.043004
42	0.778	0.222	0.2	0.8	0.778	0.222	0.004773	-0.000208	0.004565	9.7	-0.280	9.420	0.043004
43	0.222	0.778	0.2	0.8	0.778	0.222	0.004773	-0.000208	0.004565	9.7	-0.280	9.420	0.043004
44	0.222	0.778	0.8	0.2	0.778	0.222	0.004773	-0.000208	0.004565	9.7	-0.280	9.420	0.043004
45	0.222	0.778	0.2	0.8	0.222	0.778	0.004773	-0.000208	0.004565	9.7	-0.280	9.420	0.043004
46	0.222	0.778	0.8	0.2	0.222	0.222	0.001362	-0.000208	0.001154	9.7	-0.280	9.420	0.010873
47	0.778	0.222	0.2	0.2	0.222	0.778	0.001193	-0.000208	0.000985	9.7	-0.280	9.420	0.009283
48	0.778	0.222	0.2	0.2	0.778	0.222	0.001193	-0.000208	0.000985	9.7	-0.280	9.420	0.009283
49	0.222	0.778	0.2	0.8	0.222	0.222	0.001362	-0.000208	0.001154	9.7	-0.280	9.420	0.010873
50	0.222	0.778	0.2	0.2	0.222	0.778	0.001193	-0.000208	0.000985	9.7	-0.280	9.420	0.009283
51	0.778	0.222	0.8	0.2	0.222	0.222	0.001362	-0.000208	0.001154	9.7	-0.280	9.420	0.010873
52	0.222	0.222	0.2	0.8	0.778	0.222	0.001362	-0.000208	0.001154	9.7	-0.280	9.420	0.010873
53	0.222	0.778	0.2	0.2	0.778	0.222	0.001193	-0.000208	0.000985	9.7	-0.280	9.420	0.009283
54	0.778	0.222	0.2	0.8	0.222	0.222	0.001362	-0.000208	0.001154	9.7	-0.280	9.420	0.010873
55	0.222	0.222	0.8	0.2	0.222	0.778	0.001362	-0.000208	0.001154	9.7	-0.280	9.420	0.010873
56	0.222	0.222	0.8	0.2	0.778	0.222	0.001362	-0.000208	0.001154	9.7	-0.280	9.420	0.010873
57	0.222	0.222	0.2	0.8	0.222	0.778	0.001362	-0.000208	0.001154	9.7	-0.280	9.420	0.010873
58	0.222	0.778	0.2	0.2	0.222	0.222	0.000340	-0.000208	0.000133	10.0	-0.280	9.720	0.001290
59	0.222	0.222	0.8	0.2	0.222	0.222	0.000389	-0.000208	0.000181	10.0	-0.280	9.720	0.001758
60	0.222	0.222	0.2	0.8	0.222	0.222	0.000389	-0.000208	0.000181	10.0	-0.280	9.720	0.001758
61	0.778	0.222	0.2	0.2	0.222	0.222	0.000340	-0.000208	0.000133	10.0	-0.280	9.720	0.001290
62	0.222	0.222	0.2	0.2	0.222	0.778	0.000340	-0.000208	0.000133	10.0	-0.280	9.720	0.001290
63	0.222	0.222	0.2	0.2	0.778	0.222	0.000340	-0.000208	0.000133	10.0	-0.280	9.720	0.001290
64	0.222	0.222	0.2	0.2	0.222	0.222	0.000097	-0.000208	-0.000111	11.5	-0.280	11.220	-0.001241 5.954193

Example Problem 5

NBL1 - ITERATION 1

	P(a _{ol1})	P(a _{ol2})	P(a _{cl1})	P(a _{cl2})	P(a _{cr1})	P(a _{cr2})	P(i)	Adj P(i)	P'(i)	h _{base}	h _{adj}	h _{si}	P'(i)*h _{si}
1	0.7778	0.7778	0.8	0.8	0.7778	0.7778	0.234208	0.017630	0.251838	4.5	0.200	4.700	1.183638
2	0.2222	0.7778	0.8	0.8	0.7778	0.7778	0.066917	0.002814	0.069731	5.0	0.200	5.200	0.362600
3	0.7778	0.2222	0.8	0.8	0.7778	0.7778	0.066917	0.002814	0.069731	5.0	0.200	5.200	0.362600
4	0.2222	0.2222	0.8	0.8	0.7778	0.7778	0.019119	0.002814	0.021933	6.2	0.200	6.400	0.140372
5	0.7778	0.7778	0.8	0.2	0.7778	0.7778	0.058552	-0.000783	0.057769	6.4	0.200	6.600	0.381276
6	0.7778	0.7778	0.2	0.8	0.7778	0.7778	0.058552	-0.000783	0.057769	6.4	0.200	6.600	0.381276
7	0.7778	0.7778	0.8	0.8	0.2222	0.7778	0.066917	-0.000783	0.066134	6.4	0.200	6.600	0.436482
8	0.7778	0.7778	0.8	0.8	0.7778	0.2222	0.066917	-0.000783	0.066134	6.4	0.200	6.600	0.436482
9	0.7778	0.7778	0.2	0.2	0.7778	0.7778	0.014638	-0.000783	0.013855	7.2	0.200	7.400	0.102528
10	0.7778	0.7778	0.8	0.8	0.2222	0.2222	0.019119	-0.000783	0.018336	7.2	0.200	7.400	0.135687
11	0.7778	0.7778	0.8	0.2	0.7778	0.2222	0.016729	-0.000584	0.016146	7.6	0.200	7.800	0.125936
12	0.7778	0.7778	0.2	0.8	0.7778	0.2222	0.016729	-0.000584	0.016146	7.6	0.200	7.800	0.125936
13	0.7778	0.7778	0.2	0.8	0.2222	0.7778	0.016729	-0.000584	0.016146	7.6	0.200	7.800	0.125936
14	0.7778	0.7778	0.8	0.2	0.2222	0.7778	0.016729	-0.000584	0.016146	7.6	0.200	7.800	0.125936
15	0.7778	0.2222	0.8	0.2	0.7778	0.7778	0.016729	-0.000584	0.016146	7.6	0.200	7.800	0.125936
16	0.2222	0.7778	0.2	0.8	0.7778	0.7778	0.016729	-0.000584	0.016146	7.6	0.200	7.800	0.125936
17	0.7778	0.2222	0.8	0.8	0.2222	0.7778	0.019119	-0.000584	0.018535	7.6	0.200	7.800	0.144577
18	0.2222	0.7778	0.8	0.2	0.7778	0.7778	0.016729	-0.000584	0.016146	7.6	0.200	7.800	0.125936
19	0.7778	0.2222	0.2	0.8	0.7778	0.7778	0.016729	-0.000584	0.016146	7.6	0.200	7.800	0.125936
20	0.7778	0.2222	0.8	0.8	0.7778	0.2222	0.019119	-0.000584	0.018535	7.6	0.200	7.800	0.144577
21	0.2222	0.7778	0.8	0.8	0.2222	0.7778	0.019119	-0.000584	0.018535	7.6	0.200	7.800	0.144577
22	0.2222	0.7778	0.8	0.8	0.7778	0.2222	0.019119	-0.000584	0.018535	7.6	0.200	7.800	0.144577
23	0.7778	0.7778	0.8	0.2	0.2222	0.2222	0.004780	-0.000584	0.004196	7.8	0.200	8.000	0.033570
24	0.7778	0.7778	0.2	0.2	0.7778	0.2222	0.004182	-0.000584	0.003599	7.8	0.200	8.000	0.028790
25	0.7778	0.7778	0.2	0.2	0.2222	0.7778	0.004182	-0.000584	0.003599	7.8	0.200	8.000	0.028790
26	0.2222	0.7778	0.2	0.2	0.7778	0.7778	0.004182	-0.000584	0.003599	7.8	0.200	8.000	0.028790
27	0.2222	0.2222	0.2	0.8	0.7778	0.7778	0.004780	-0.000584	0.004196	7.8	0.200	8.000	0.033570
28	0.2222	0.2222	0.8	0.8	0.2222	0.7778	0.005463	-0.000584	0.004879	7.8	0.200	8.000	0.039032
29	0.2222	0.2222	0.8	0.8	0.7778	0.2222	0.005463	-0.000584	0.004879	7.8	0.200	8.000	0.039032
30	0.7778	0.2222	0.2	0.2	0.7778	0.7778	0.004182	-0.000584	0.003599	7.8	0.200	8.000	0.028790
31	0.2222	0.7778	0.8	0.8	0.2222	0.2222	0.005463	-0.000584	0.004879	7.8	0.200	8.000	0.039032
32	0.7778	0.7778	0.2	0.8	0.2222	0.2222	0.004780	-0.000584	0.004196	7.8	0.200	8.000	0.033570
33	0.2222	0.2222	0.8	0.2	0.7778	0.7778	0.004780	-0.000584	0.004196	7.8	0.200	8.000	0.033570
34	0.7778	0.2222	0.8	0.8	0.2222	0.2222	0.005463	-0.000584	0.004879	7.8	0.200	8.000	0.039032
35	0.2222	0.2222	0.8	0.8	0.2222	0.2222	0.001561	-0.000584	0.000977	9.0	0.200	9.200	0.008990
36	0.7778	0.7778	0.2	0.2	0.2222	0.2222	0.001195	-0.000584	0.000611	9.0	0.200	9.200	0.005625
37	0.2222	0.2222	0.2	0.2	0.7778	0.7778	0.001195	-0.000584	0.000611	9.0	0.200	9.200	0.005625
38	0.7778	0.2222	0.8	0.2	0.7778	0.2222	0.004780	-0.000208	0.004572	9.7	0.200	9.900	0.045259
39	0.2222	0.7778	0.8	0.2	0.2222	0.7778	0.004780	-0.000208	0.004572	9.7	0.200	9.900	0.045259
40	0.7778	0.2222	0.2	0.8	0.2222	0.7778	0.004780	-0.000208	0.004572	9.7	0.200	9.900	0.045259
41	0.7778	0.2222	0.8	0.2	0.2222	0.7778	0.004780	-0.000208	0.004572	9.7	0.200	9.900	0.045259
42	0.7778	0.2222	0.2	0.8	0.7778	0.2222	0.004780	-0.000208	0.004572	9.7	0.200	9.900	0.045259
43	0.2222	0.7778	0.2	0.8	0.7778	0.2222	0.004780	-0.000208	0.004572	9.7	0.200	9.900	0.045259
44	0.2222	0.7778	0.8	0.2	0.7778	0.2222	0.004780	-0.000208	0.004572	9.7	0.200	9.900	0.045259
45	0.2222	0.7778	0.2	0.8	0.2222	0.7778	0.004780	-0.000208	0.004572	9.7	0.200	9.900	0.045259
46	0.2222	0.7778	0.8	0.2	0.2222	0.2222	0.001366	-0.000208	0.001158	9.7	0.200	9.900	0.011460
47	0.7778	0.2222	0.2	0.2	0.2222	0.7778	0.001195	-0.000208	0.000987	9.7	0.200	9.900	0.009770
48	0.7778	0.2222	0.2	0.2	0.7778	0.2222	0.001195	-0.000208	0.000987	9.7	0.200	9.900	0.009770
49	0.2222	0.7778	0.2	0.8	0.2222	0.2222	0.001366	-0.000208	0.001158	9.7	0.200	9.900	0.011460
50	0.2222	0.7778	0.2	0.2	0.2222	0.7778	0.001195	-0.000208	0.000987	9.7	0.200	9.900	0.009770
51	0.7778	0.2222	0.8	0.2	0.2222	0.2222	0.001366	-0.000208	0.001158	9.7	0.200	9.900	0.011460
52	0.2222	0.2222	0.2	0.8	0.7778	0.2222	0.001366	-0.000208	0.001158	9.7	0.200	9.900	0.011460
53	0.2222	0.7778	0.2	0.2	0.7778	0.2222	0.001195	-0.000208	0.000987	9.7	0.200	9.900	0.009770
54	0.7778	0.2222	0.2	0.8	0.2222	0.2222	0.001366	-0.000208	0.001158	9.7	0.200	9.900	0.011460
55	0.2222	0.2222	0.8	0.2	0.2222	0.7778	0.001366	-0.000208	0.001158	9.7	0.200	9.900	0.011460
56	0.2222	0.2222	0.8	0.2	0.7778	0.2222	0.001366	-0.000208	0.001158	9.7	0.200	9.900	0.011460
57	0.2222	0.2222	0.2	0.8	0.2222	0.7778	0.001366	-0.000208	0.001158	9.7	0.200	9.900	0.011460
58	0.2222	0.7778	0.2	0.2	0.2222	0.2222	0.000341	-0.000208	0.000133	10.0	0.200	10.200	0.001360
59	0.2222	0.2222	0.8	0.2	0.2222	0.2222	0.000390	-0.000208	0.000182	10.0	0.200	10.200	0.001857
60	0.2222	0.2222	0.2	0.8	0.2222	0.2222	0.000390	-0.000208	0.000182	10.0	0.200	10.200	0.001857
61	0.7778	0.2222	0.2	0.2	0.2222	0.2222	0.000341	-0.000208	0.000133	10.0	0.200	10.200	0.001360
62	0.2222	0.2222	0.2	0.2	0.2222	0.7778	0.000341	-0.000208	0.000133	10.0	0.200	10.200	0.001360
63	0.2222	0.2222	0.2	0.2	0.7778	0.2222	0.000341	-0.000208	0.000133	10.0	0.200	10.200	0.001360
64	0.2222	0.2222	0.2	0.2	0.2222	0.2222	0.000098	-0.000208	-0.000111	11.5	0.200	11.700	-0.001293 6.435236

NBL2 - ITERATION 1

Example Problem 5

	P(a _{ol1})	P(a _{ol2})	P(a _{cl1})	P(a _{cl2})	P(a _{CR1})	P(a _{CR2})	P(i)	Adj P(i)	P'(i)	h _{base}	h _{adj}	h _{sl}	P'(i)*h _{sl}
1	0.778	0.778	0.8	0.8	0.778	0.778	0.234476	0.017621	0.252096	4.5	-0.140	4.360	1.099141
2	0.222	0.778	0.8	0.8	0.778	0.778	0.066907	0.002812	0.069719	5.0	-0.140	4.860	0.338835
3	0.778	0.222	0.8	0.8	0.778	0.778	0.066907	0.002812	0.069719	5.0	-0.140	4.860	0.338835
4	0.222	0.222	0.8	0.8	0.778	0.778	0.019092	0.002812	0.021904	6.2	-0.140	6.060	0.132737
5	0.778	0.778	0.8	0.2	0.778	0.778	0.058619	-0.000784	0.057835	6.4	-0.140	6.260	0.362046
6	0.778	0.778	0.2	0.8	0.778	0.778	0.058619	-0.000784	0.057835	6.4	-0.140	6.260	0.362046
7	0.778	0.778	0.8	0.8	0.222	0.778	0.066907	-0.000784	0.066123	6.4	-0.140	6.260	0.413929
8	0.778	0.778	0.8	0.8	0.778	0.222	0.066907	-0.000784	0.066123	6.4	-0.140	6.260	0.413929
9	0.778	0.778	0.2	0.2	0.778	0.778	0.014655	-0.000784	0.013871	7.2	-0.140	7.060	0.097926
10	0.778	0.778	0.8	0.8	0.222	0.222	0.019092	-0.000784	0.018308	7.2	-0.140	7.060	0.129251
11	0.778	0.778	0.8	0.2	0.778	0.222	0.016727	-0.000583	0.016144	7.6	-0.140	7.460	0.120432
12	0.778	0.778	0.2	0.8	0.778	0.222	0.016727	-0.000583	0.016144	7.6	-0.140	7.460	0.120432
13	0.778	0.778	0.2	0.8	0.222	0.778	0.016727	-0.000583	0.016144	7.6	-0.140	7.460	0.120432
14	0.778	0.778	0.8	0.2	0.222	0.778	0.016727	-0.000583	0.016144	7.6	-0.140	7.460	0.120432
15	0.778	0.222	0.8	0.2	0.778	0.778	0.016727	-0.000583	0.016144	7.6	-0.140	7.460	0.120432
16	0.222	0.778	0.2	0.8	0.778	0.778	0.016727	-0.000583	0.016144	7.6	-0.140	7.460	0.120432
17	0.778	0.222	0.8	0.8	0.222	0.778	0.019092	-0.000583	0.018509	7.6	-0.140	7.460	0.138075
18	0.222	0.778	0.8	0.2	0.778	0.778	0.016727	-0.000583	0.016144	7.6	-0.140	7.460	0.120432
19	0.778	0.222	0.2	0.8	0.778	0.778	0.016727	-0.000583	0.016144	7.6	-0.140	7.460	0.120432
20	0.778	0.222	0.8	0.8	0.778	0.222	0.019092	-0.000583	0.018509	7.6	-0.140	7.460	0.138075
21	0.222	0.778	0.8	0.8	0.222	0.778	0.019092	-0.000583	0.018509	7.6	-0.140	7.460	0.138075
22	0.222	0.778	0.8	0.8	0.778	0.222	0.019092	-0.000583	0.018509	7.6	-0.140	7.460	0.138075
23	0.778	0.778	0.8	0.2	0.222	0.222	0.004773	-0.000583	0.004190	7.8	-0.140	7.660	0.032094
24	0.778	0.778	0.2	0.2	0.778	0.222	0.004182	-0.000583	0.003599	7.8	-0.140	7.660	0.027565
25	0.778	0.778	0.2	0.2	0.222	0.778	0.004182	-0.000583	0.003599	7.8	-0.140	7.660	0.027565
26	0.222	0.778	0.2	0.2	0.778	0.778	0.004182	-0.000583	0.003599	7.8	-0.140	7.660	0.027565
27	0.222	0.222	0.2	0.8	0.778	0.778	0.004773	-0.000583	0.004190	7.8	-0.140	7.660	0.032094
28	0.222	0.222	0.8	0.8	0.222	0.778	0.005448	-0.000583	0.004865	7.8	-0.140	7.660	0.037264
29	0.222	0.222	0.8	0.8	0.778	0.222	0.005448	-0.000583	0.004865	7.8	-0.140	7.660	0.037264
30	0.778	0.222	0.2	0.2	0.778	0.778	0.004182	-0.000583	0.003599	7.8	-0.140	7.660	0.027565
31	0.222	0.778	0.8	0.8	0.222	0.222	0.005448	-0.000583	0.004865	7.8	-0.140	7.660	0.037264
32	0.778	0.778	0.2	0.8	0.222	0.222	0.004773	-0.000583	0.004190	7.8	-0.140	7.660	0.032094
33	0.222	0.222	0.8	0.2	0.778	0.778	0.004773	-0.000583	0.004190	7.8	-0.140	7.660	0.032094
34	0.778	0.222	0.8	0.8	0.222	0.222	0.005448	-0.000583	0.004865	7.8	-0.140	7.660	0.037264
35	0.222	0.222	0.8	0.8	0.222	0.222	0.001555	-0.000583	0.000971	9.0	-0.140	8.860	0.008607
36	0.778	0.778	0.2	0.2	0.222	0.222	0.001193	-0.000583	0.000610	9.0	-0.140	8.860	0.005406
37	0.222	0.222	0.2	0.2	0.778	0.778	0.001193	-0.000583	0.000610	9.0	-0.140	8.860	0.005406
38	0.778	0.222	0.8	0.2	0.778	0.222	0.004773	-0.000208	0.004565	9.7	-0.140	9.560	0.043643
39	0.222	0.778	0.8	0.2	0.222	0.778	0.004773	-0.000208	0.004565	9.7	-0.140	9.560	0.043643
40	0.778	0.222	0.2	0.8	0.222	0.778	0.004773	-0.000208	0.004565	9.7	-0.140	9.560	0.043643
41	0.778	0.222	0.8	0.2	0.222	0.778	0.004773	-0.000208	0.004565	9.7	-0.140	9.560	0.043643
42	0.778	0.222	0.2	0.8	0.778	0.222	0.004773	-0.000208	0.004565	9.7	-0.140	9.560	0.043643
43	0.222	0.778	0.2	0.8	0.778	0.222	0.004773	-0.000208	0.004565	9.7	-0.140	9.560	0.043643
44	0.222	0.778	0.8	0.2	0.778	0.222	0.004773	-0.000208	0.004565	9.7	-0.140	9.560	0.043643
45	0.222	0.778	0.2	0.8	0.222	0.778	0.004773	-0.000208	0.004565	9.7	-0.140	9.560	0.043643
46	0.222	0.778	0.8	0.2	0.222	0.222	0.001362	-0.000208	0.001154	9.7	-0.140	9.560	0.011034
47	0.778	0.222	0.2	0.2	0.222	0.778	0.001193	-0.000208	0.000985	9.7	-0.140	9.560	0.009421
48	0.778	0.222	0.2	0.2	0.778	0.222	0.001193	-0.000208	0.000985	9.7	-0.140	9.560	0.009421
49	0.222	0.778	0.2	0.8	0.222	0.222	0.001362	-0.000208	0.001154	9.7	-0.140	9.560	0.011034
50	0.222	0.778	0.2	0.2	0.222	0.778	0.001193	-0.000208	0.000985	9.7	-0.140	9.560	0.009421
51	0.778	0.222	0.8	0.2	0.222	0.222	0.001362	-0.000208	0.001154	9.7	-0.140	9.560	0.011034
52	0.222	0.222	0.2	0.8	0.778	0.222	0.001362	-0.000208	0.001154	9.7	-0.140	9.560	0.011034
53	0.222	0.778	0.2	0.2	0.778	0.222	0.001193	-0.000208	0.000985	9.7	-0.140	9.560	0.009421
54	0.778	0.222	0.2	0.8	0.222	0.222	0.001362	-0.000208	0.001154	9.7	-0.140	9.560	0.011034
55	0.222	0.222	0.8	0.2	0.222	0.778	0.001362	-0.000208	0.001154	9.7	-0.140	9.560	0.011034
56	0.222	0.222	0.8	0.2	0.778	0.222	0.001362	-0.000208	0.001154	9.7	-0.140	9.560	0.011034
57	0.222	0.222	0.2	0.8	0.222	0.778	0.001362	-0.000208	0.001154	9.7	-0.140	9.560	0.011034
58	0.222	0.778	0.2	0.2	0.222	0.222	0.000340	-0.000208	0.000133	10.0	-0.140	9.860	0.001309
59	0.222	0.222	0.8	0.2	0.222	0.222	0.000389	-0.000208	0.000181	10.0	-0.140	9.860	0.001784
60	0.222	0.222	0.2	0.8	0.222	0.222	0.000389	-0.000208	0.000181	10.0	-0.140	9.860	0.001784
61	0.778	0.222	0.2	0.2	0.222	0.222	0.000340	-0.000208	0.000133	10.0	-0.140	9.860	0.001309
62	0.222	0.222	0.2	0.2	0.222	0.778	0.000340	-0.000208	0.000133	10.0	-0.140	9.860	0.001309
63	0.222	0.222	0.2	0.2	0.778	0.222	0.000340	-0.000208	0.000133	10.0	-0.140	9.860	0.001309
64	0.222	0.222	0.2	0.2	0.222	0.222	0.000097	-0.000208	-0.000111	11.5	-0.140	11.360	-0.001256 6.094193

Example Problem 5

SBL1 - ITERATION 1

	P(a _{ol1})	P(a _{ol2})	P(a _{cl1})	P(a _{cl2})	P(a _{CR1})	P(a _{CR2})	P(i)	Adj P(i)	P'(i)	h _{base}	h _{adj}	h _{si}	P'(i)*h _{si}
1	0.778	0.778	0.778	0.778	0.8	0.8	0.234476	0.017621	0.252096	4.5	0.100	4.600	1.159644
2	0.222	0.778	0.778	0.778	0.8	0.8	0.066907	0.002812	0.069719	5.0	0.100	5.100	0.355567
3	0.778	0.222	0.778	0.778	0.8	0.8	0.066907	0.002812	0.069719	5.0	0.100	5.100	0.355567
4	0.222	0.222	0.778	0.778	0.8	0.8	0.019092	0.002812	0.021904	6.2	0.100	6.300	0.137994
5	0.778	0.778	0.778	0.222	0.8	0.8	0.066907	-0.000784	0.066123	6.4	0.100	6.500	0.429799
6	0.778	0.778	0.222	0.778	0.8	0.8	0.066907	-0.000784	0.066123	6.4	0.100	6.500	0.429799
7	0.778	0.778	0.778	0.778	0.2	0.8	0.058619	-0.000784	0.057835	6.4	0.100	6.500	0.375927
8	0.778	0.778	0.778	0.778	0.8	0.2	0.058619	-0.000784	0.057835	6.4	0.100	6.500	0.375927
9	0.778	0.778	0.222	0.222	0.8	0.8	0.019092	-0.000784	0.018308	7.2	0.100	7.300	0.133645
10	0.778	0.778	0.778	0.778	0.2	0.2	0.014655	-0.000784	0.013871	7.2	0.100	7.300	0.101255
11	0.778	0.778	0.778	0.222	0.8	0.2	0.016727	-0.000583	0.016144	7.6	0.100	7.700	0.124306
12	0.778	0.778	0.222	0.778	0.8	0.2	0.016727	-0.000583	0.016144	7.6	0.100	7.700	0.124306
13	0.778	0.778	0.222	0.778	0.2	0.8	0.016727	-0.000583	0.016144	7.6	0.100	7.700	0.124306
14	0.778	0.778	0.778	0.222	0.2	0.8	0.016727	-0.000583	0.016144	7.6	0.100	7.700	0.124306
15	0.778	0.222	0.778	0.222	0.8	0.8	0.019092	-0.000583	0.018509	7.6	0.100	7.700	0.142517
16	0.222	0.778	0.222	0.778	0.8	0.8	0.019092	-0.000583	0.018509	7.6	0.100	7.700	0.142517
17	0.778	0.222	0.778	0.778	0.2	0.8	0.016727	-0.000583	0.016144	7.6	0.100	7.700	0.124306
18	0.222	0.778	0.778	0.222	0.8	0.8	0.019092	-0.000583	0.018509	7.6	0.100	7.700	0.142517
19	0.778	0.222	0.222	0.778	0.8	0.8	0.019092	-0.000583	0.018509	7.6	0.100	7.700	0.142517
20	0.778	0.222	0.778	0.778	0.8	0.2	0.016727	-0.000583	0.016144	7.6	0.100	7.700	0.124306
21	0.222	0.778	0.778	0.778	0.2	0.8	0.016727	-0.000583	0.016144	7.6	0.100	7.700	0.124306
22	0.222	0.778	0.778	0.778	0.8	0.2	0.016727	-0.000583	0.016144	7.6	0.100	7.700	0.124306
23	0.778	0.778	0.778	0.222	0.2	0.2	0.004182	-0.000583	0.003599	7.8	0.100	7.900	0.028429
24	0.778	0.778	0.222	0.222	0.8	0.2	0.004773	-0.000583	0.004190	7.8	0.100	7.900	0.033100
25	0.778	0.778	0.222	0.222	0.2	0.8	0.004773	-0.000583	0.004190	7.8	0.100	7.900	0.033100
26	0.222	0.778	0.222	0.222	0.8	0.8	0.005448	-0.000583	0.004865	7.8	0.100	7.900	0.038431
27	0.222	0.222	0.222	0.778	0.8	0.8	0.005448	-0.000583	0.004865	7.8	0.100	7.900	0.038431
28	0.222	0.222	0.778	0.778	0.2	0.8	0.004773	-0.000583	0.004190	7.8	0.100	7.900	0.033100
29	0.222	0.222	0.778	0.778	0.8	0.2	0.004773	-0.000583	0.004190	7.8	0.100	7.900	0.033100
30	0.778	0.222	0.222	0.222	0.8	0.8	0.005448	-0.000583	0.004865	7.8	0.100	7.900	0.038431
31	0.222	0.778	0.778	0.778	0.2	0.2	0.004182	-0.000583	0.003599	7.8	0.100	7.900	0.028429
32	0.778	0.778	0.222	0.778	0.2	0.2	0.004182	-0.000583	0.003599	7.8	0.100	7.900	0.028429
33	0.222	0.222	0.778	0.222	0.8	0.8	0.005448	-0.000583	0.004865	7.8	0.100	7.900	0.038431
34	0.778	0.222	0.778	0.778	0.2	0.2	0.004182	-0.000583	0.003599	7.8	0.100	7.900	0.028429
35	0.222	0.222	0.778	0.778	0.2	0.2	0.001193	-0.000583	0.000610	9.0	0.100	9.100	0.005552
36	0.778	0.778	0.222	0.222	0.2	0.2	0.001193	-0.000583	0.000610	9.0	0.100	9.100	0.005552
37	0.222	0.222	0.222	0.222	0.8	0.8	0.001555	-0.000583	0.000971	9.0	0.100	9.100	0.008840
38	0.778	0.222	0.778	0.222	0.8	0.2	0.004773	-0.000208	0.004565	9.7	0.100	9.800	0.044739
39	0.222	0.778	0.778	0.222	0.2	0.8	0.004773	-0.000208	0.004565	9.7	0.100	9.800	0.044739
40	0.778	0.222	0.222	0.778	0.2	0.8	0.004773	-0.000208	0.004565	9.7	0.100	9.800	0.044739
41	0.778	0.222	0.778	0.222	0.2	0.8	0.004773	-0.000208	0.004565	9.7	0.100	9.800	0.044739
42	0.778	0.222	0.222	0.778	0.8	0.2	0.004773	-0.000208	0.004565	9.7	0.100	9.800	0.044739
43	0.222	0.778	0.222	0.778	0.8	0.2	0.004773	-0.000208	0.004565	9.7	0.100	9.800	0.044739
44	0.222	0.778	0.778	0.222	0.8	0.2	0.004773	-0.000208	0.004565	9.7	0.100	9.800	0.044739
45	0.222	0.778	0.222	0.778	0.2	0.8	0.004773	-0.000208	0.004565	9.7	0.100	9.800	0.044739
46	0.222	0.778	0.778	0.222	0.2	0.2	0.001193	-0.000208	0.000985	9.7	0.100	9.800	0.009658
47	0.778	0.222	0.222	0.222	0.2	0.8	0.001362	-0.000208	0.001154	9.7	0.100	9.800	0.011311
48	0.778	0.222	0.222	0.222	0.8	0.2	0.001362	-0.000208	0.001154	9.7	0.100	9.800	0.011311
49	0.222	0.778	0.222	0.778	0.2	0.2	0.001193	-0.000208	0.000985	9.7	0.100	9.800	0.009658
50	0.222	0.778	0.222	0.222	0.2	0.8	0.001362	-0.000208	0.001154	9.7	0.100	9.800	0.011311
51	0.778	0.222	0.778	0.222	0.2	0.2	0.001193	-0.000208	0.000985	9.7	0.100	9.800	0.009658
52	0.222	0.222	0.222	0.778	0.8	0.2	0.001362	-0.000208	0.001154	9.7	0.100	9.800	0.011311
53	0.222	0.778	0.222	0.222	0.8	0.2	0.001362	-0.000208	0.001154	9.7	0.100	9.800	0.011311
54	0.778	0.222	0.222	0.778	0.2	0.2	0.001193	-0.000208	0.000985	9.7	0.100	9.800	0.009658
55	0.222	0.222	0.778	0.222	0.2	0.8	0.001362	-0.000208	0.001154	9.7	0.100	9.800	0.011311
56	0.222	0.222	0.778	0.222	0.8	0.2	0.001362	-0.000208	0.001154	9.7	0.100	9.800	0.011311
57	0.222	0.222	0.222	0.778	0.2	0.8	0.001362	-0.000208	0.001154	9.7	0.100	9.800	0.011311
58	0.222	0.778	0.222	0.222	0.2	0.2	0.000340	-0.000208	0.000133	10.0	0.100	10.100	0.001341
59	0.222	0.222	0.778	0.222	0.2	0.2	0.000340	-0.000208	0.000133	10.0	0.100	10.100	0.001341
60	0.222	0.222	0.222	0.778	0.2	0.2	0.000340	-0.000208	0.000133	10.0	0.100	10.100	0.001341
61	0.778	0.222	0.222	0.222	0.2	0.2	0.000340	-0.000208	0.000133	10.0	0.100	10.100	0.001341
62	0.222	0.222	0.222	0.222	0.2	0.8	0.000389	-0.000208	0.000181	10.0	0.100	10.100	0.001827
63	0.222	0.222	0.222	0.222	0.8	0.2	0.000389	-0.000208	0.000181	10.0	0.100	10.100	0.001827
64	0.222	0.222	0.222	0.222	0.2	0.2	0.000097	-0.000208	-0.000111	11.5	0.100	11.600	-0.001283 6.334193

SBL2 - ITERATION 1

	P(a _{ol1})	P(a _{ol2})	P(a _{cl1})	P(a _{cl2})	P(a _{cr1})	P(a _{cr2})	P(i)	Adj P(i)	P'(i)	h _{base}	h _{adj}	h _{sl}	P'(i)*h _{sl}
1	0.778	0.778	0.778	0.778	0.8	0.8	0.234476	0.017621	0.252096	4.5	-0.420	4.080	1.028554
2	0.222	0.778	0.778	0.778	0.8	0.8	0.066907	0.002812	0.069719	5.0	-0.420	4.580	0.319313
3	0.778	0.222	0.778	0.778	0.8	0.8	0.066907	0.002812	0.069719	5.0	-0.420	4.580	0.319313
4	0.222	0.222	0.778	0.778	0.8	0.8	0.019092	0.002812	0.021904	6.2	-0.420	5.780	0.126604
5	0.778	0.778	0.778	0.222	0.8	0.8	0.066907	-0.000784	0.066123	6.4	-0.420	5.980	0.395415
6	0.778	0.778	0.222	0.778	0.8	0.8	0.066907	-0.000784	0.066123	6.4	-0.420	5.980	0.395415
7	0.778	0.778	0.778	0.778	0.2	0.8	0.058619	-0.000784	0.057835	6.4	-0.420	5.980	0.345852
8	0.778	0.778	0.778	0.778	0.8	0.2	0.058619	-0.000784	0.057835	6.4	-0.420	5.980	0.345852
9	0.778	0.778	0.222	0.222	0.8	0.8	0.019092	-0.000784	0.018308	7.2	-0.420	6.780	0.124125
10	0.778	0.778	0.778	0.778	0.2	0.2	0.014655	-0.000784	0.013871	7.2	-0.420	6.780	0.094043
11	0.778	0.778	0.778	0.222	0.8	0.2	0.016727	-0.000583	0.016144	7.6	-0.420	7.180	0.115912
12	0.778	0.778	0.222	0.778	0.8	0.2	0.016727	-0.000583	0.016144	7.6	-0.420	7.180	0.115912
13	0.778	0.778	0.222	0.778	0.2	0.8	0.016727	-0.000583	0.016144	7.6	-0.420	7.180	0.115912
14	0.778	0.778	0.778	0.222	0.2	0.8	0.016727	-0.000583	0.016144	7.6	-0.420	7.180	0.115912
15	0.778	0.222	0.778	0.222	0.8	0.8	0.019092	-0.000583	0.018509	7.6	-0.420	7.180	0.132892
16	0.222	0.778	0.222	0.778	0.8	0.8	0.019092	-0.000583	0.018509	7.6	-0.420	7.180	0.132892
17	0.778	0.222	0.778	0.778	0.2	0.8	0.016727	-0.000583	0.016144	7.6	-0.420	7.180	0.115912
18	0.222	0.778	0.778	0.222	0.8	0.8	0.019092	-0.000583	0.018509	7.6	-0.420	7.180	0.132892
19	0.778	0.222	0.222	0.778	0.8	0.8	0.019092	-0.000583	0.018509	7.6	-0.420	7.180	0.132892
20	0.778	0.222	0.778	0.778	0.8	0.2	0.016727	-0.000583	0.016144	7.6	-0.420	7.180	0.115912
21	0.222	0.778	0.778	0.778	0.2	0.8	0.016727	-0.000583	0.016144	7.6	-0.420	7.180	0.115912
22	0.222	0.778	0.778	0.778	0.8	0.2	0.016727	-0.000583	0.016144	7.6	-0.420	7.180	0.115912
23	0.778	0.778	0.778	0.222	0.2	0.2	0.004182	-0.000583	0.003599	7.8	-0.420	7.380	0.026558
24	0.778	0.778	0.222	0.222	0.8	0.2	0.004773	-0.000583	0.004190	7.8	-0.420	7.380	0.030921
25	0.778	0.778	0.222	0.222	0.2	0.8	0.004773	-0.000583	0.004190	7.8	-0.420	7.380	0.030921
26	0.222	0.778	0.222	0.222	0.8	0.8	0.005448	-0.000583	0.004865	7.8	-0.420	7.380	0.035901
27	0.222	0.222	0.222	0.778	0.8	0.8	0.005448	-0.000583	0.004865	7.8	-0.420	7.380	0.035901
28	0.222	0.222	0.778	0.778	0.2	0.8	0.004773	-0.000583	0.004190	7.8	-0.420	7.380	0.030921
29	0.222	0.222	0.778	0.778	0.8	0.2	0.004773	-0.000583	0.004190	7.8	-0.420	7.380	0.030921
30	0.778	0.222	0.222	0.222	0.8	0.8	0.005448	-0.000583	0.004865	7.8	-0.420	7.380	0.035901
31	0.222	0.778	0.778	0.778	0.2	0.2	0.004182	-0.000583	0.003599	7.8	-0.420	7.380	0.026558
32	0.778	0.778	0.222	0.778	0.2	0.2	0.004182	-0.000583	0.003599	7.8	-0.420	7.380	0.026558
33	0.222	0.222	0.778	0.222	0.8	0.8	0.005448	-0.000583	0.004865	7.8	-0.420	7.380	0.035901
34	0.778	0.222	0.778	0.778	0.2	0.2	0.004182	-0.000583	0.003599	7.8	-0.420	7.380	0.026558
35	0.222	0.222	0.778	0.778	0.2	0.2	0.001193	-0.000583	0.000610	9.0	-0.420	8.580	0.005235
36	0.778	0.778	0.222	0.222	0.2	0.2	0.001193	-0.000583	0.000610	9.0	-0.420	8.580	0.005235
37	0.222	0.222	0.222	0.222	0.8	0.8	0.001555	-0.000583	0.000971	9.0	-0.420	8.580	0.008335
38	0.778	0.222	0.778	0.222	0.8	0.2	0.004773	-0.000208	0.004565	9.7	-0.420	9.280	0.042365
39	0.222	0.778	0.778	0.222	0.2	0.8	0.004773	-0.000208	0.004565	9.7	-0.420	9.280	0.042365
40	0.778	0.222	0.222	0.778	0.2	0.8	0.004773	-0.000208	0.004565	9.7	-0.420	9.280	0.042365
41	0.778	0.222	0.778	0.222	0.2	0.8	0.004773	-0.000208	0.004565	9.7	-0.420	9.280	0.042365
42	0.778	0.222	0.222	0.778	0.8	0.2	0.004773	-0.000208	0.004565	9.7	-0.420	9.280	0.042365
43	0.222	0.778	0.222	0.778	0.8	0.2	0.004773	-0.000208	0.004565	9.7	-0.420	9.280	0.042365
44	0.222	0.778	0.778	0.222	0.8	0.2	0.004773	-0.000208	0.004565	9.7	-0.420	9.280	0.042365
45	0.222	0.778	0.222	0.778	0.2	0.8	0.004773	-0.000208	0.004565	9.7	-0.420	9.280	0.042365
46	0.222	0.778	0.778	0.222	0.2	0.2	0.001193	-0.000208	0.000985	9.7	-0.420	9.280	0.009145
47	0.778	0.222	0.222	0.222	0.2	0.8	0.001362	-0.000208	0.001154	9.7	-0.420	9.280	0.010711
48	0.778	0.222	0.222	0.222	0.8	0.2	0.001362	-0.000208	0.001154	9.7	-0.420	9.280	0.010711
49	0.222	0.778	0.222	0.778	0.2	0.2	0.001193	-0.000208	0.000985	9.7	-0.420	9.280	0.009145
50	0.222	0.778	0.222	0.222	0.2	0.8	0.001362	-0.000208	0.001154	9.7	-0.420	9.280	0.010711
51	0.778	0.222	0.778	0.222	0.2	0.2	0.001193	-0.000208	0.000985	9.7	-0.420	9.280	0.009145
52	0.222	0.222	0.222	0.778	0.8	0.2	0.001362	-0.000208	0.001154	9.7	-0.420	9.280	0.010711
53	0.222	0.778	0.222	0.222	0.8	0.2	0.001362	-0.000208	0.001154	9.7	-0.420	9.280	0.010711
54	0.778	0.222	0.222	0.778	0.2	0.2	0.001193	-0.000208	0.000985	9.7	-0.420	9.280	0.009145
55	0.222	0.222	0.778	0.222	0.2	0.8	0.001362	-0.000208	0.001154	9.7	-0.420	9.280	0.010711
56	0.222	0.222	0.778	0.222	0.8	0.2	0.001362	-0.000208	0.001154	9.7	-0.420	9.280	0.010711
57	0.222	0.222	0.222	0.778	0.2	0.8	0.001362	-0.000208	0.001154	9.7	-0.420	9.280	0.010711
58	0.222	0.778	0.222	0.222	0.2	0.2	0.000340	-0.000208	0.000133	10.0	-0.420	9.580	0.001272
59	0.222	0.222	0.778	0.222	0.2	0.2	0.000340	-0.000208	0.000133	10.0	-0.420	9.580	0.001272
60	0.222	0.222	0.222	0.778	0.2	0.2	0.000340	-0.000208	0.000133	10.0	-0.420	9.580	0.001272
61	0.778	0.222	0.222	0.222	0.2	0.2	0.000340	-0.000208	0.000133	10.0	-0.420	9.580	0.001272
62	0.222	0.222	0.222	0.222	0.2	0.8	0.000389	-0.000208	0.000181	10.0	-0.420	9.580	0.001733
63	0.222	0.222	0.222	0.222	0.8	0.2	0.000389	-0.000208	0.000181	10.0	-0.420	9.580	0.001733
64	0.222	0.222	0.222	0.222	0.2	0.2	0.000097	-0.000208	-0.000111	11.5	-0.420	11.080	-0.001225 5.814193

Example Problem 5

Example Problem 5

AWSC - UNSIGNALIZED INTERSECTIONS WORKSHEET								
Worksheet 5								
General Information								
Project Description <u>Example Problem 5</u>								
Capacity and Level of Service								
	EB		WB		NB		SB	
	L1	L2	L1	L2	L1	L2	L1	L2
Total lane flow rate (veh/h)	225	225	250	250	250	250	250	250
Departure headway, h_d (s)	8.708	8.331	8.686	8.206	8.686	8.346	8.586	8.066
Degree of utilization, x	0.554	0.521	0.603	0.570	0.603	0.580	0.596	0.560
Move-up time, m (s)	2.30	2.30	2.30	2.30	2.30	2.30	2.30	2.30
Service time, t_s (s)	6.408	6.031	6.386	5.906	6.386	6.046	6.286	5.766
Capacity (veh/h)	385	400	390	410	410	430	395	420
Delay (s) (Equation 17-55)	21.3	19.7	23.7	21.2	23.7	21.9	23.2	20.6
Level of service (Exhibit 17-22)	C	C	C	C	C	C	C	C
Delay, approach (s/veh)	20.5		22.5		22.8		21.9	
Level of service, approach	C		C		C		C	
Delay, intersection (s/veh)	22.0							
Level of service, intersection	C							

EXAMPLE PROBLEM 6

Roundabout A four-leg roundabout.

The Question What are the capacity and v/c ratio?

The Facts

- √ Two two-way, two-lane streets, √ PHF = 1.00, and
- √ One-lane roundabout, √ Duration T = 0.25 h.
- √ Circulating flow less than 1,200 veh/h,

Outline to Solution The steps below show the eastbound approach calculations only. Calculations for other approaches are shown on the worksheets.

Steps

1. Input project information and movement volumes	
2. Adjust traffic volumes for peaking approach flows	$V_x = \frac{\text{Volume}}{\text{PHF}}$ $V_{\text{EBLT}} = \frac{247}{1.00} = 247 \text{ veh/h}$
3. Circulating flow (use equations provided in the Worksheet). Note that Exhibit 17-39 shows movement designations	$V_{c,E} = V_4 + V_{10} + V_{11}$ $V_{c,E} = 103 + 254 + 94 = 451 \text{ veh/h}$
4. Compute upper-bound and lower-bound capacities (use Equation 17-70 and Exhibit 17-37)	$C_a = \frac{v_c e^{-v_c t_c / 3,600}}{1 - e^{-v_c t_r / 3,600}}$ <p>EB upper-bound capacity</p> $C_a = \frac{451 e^{-451(4.1) / 3,600}}{1 - e^{-451(2.6) / 3,600}} = 971 \text{ veh/h}$ <p>EB lower-bound capacity</p> $C_a = \frac{451 e^{-451(4.6) / 3,600}}{1 - e^{-451(3.1) / 3,600}} = 788 \text{ veh/h}$
5. v/c ratio	<p>EB upper-bound v/c = $\frac{V_{a,E}}{C_{EB}}$</p> $v/c = \frac{660}{971} = 0.680$

Comments

As a concluding comment, it is useful to show how variations in the critical gap and follow-up time values can affect the analysis results. The results obtained above can be used as a point of reference. To see what happens when alternative values are used, the results obtained from these values are compared with those obtained by using the upper-bound and lower-bound combinations. The table below shows that shifting to the upper-bound solution produces about an 11 percent increase in the v/c ratio, whereas shifting to the lower-bound values produces about a 10 percent decrease. From the westbound approach, the capacity increases to 864 veh/h with the upper-bound values and decreases to 693 veh/h with the lower-bound values. The implication is that variations of about ±10 percent can be obtained by deviating from the midpoints of the value ranges.

Example Problem 6

EFFECTS OF CHANGES IN CRITICAL GAP AND MOVE-UP TIME			
	Scenario		
	A	B	C
t_f	3.10	2.85	2.60
t_c	4.60	4.35	4.10
Capacity (Equation 17-70)			
EB	788	871	971
WB	693	770	864
NB	573	644	728
SB	667	744	835
v/c Ratio			
EB	0.84	0.76	0.68
WB	0.83	0.80	0.72
NB	0.74	0.66	0.59
SB	0.75	0.67	0.60

ROUNDBABOUTS - UNSIGNALIZED INTERSECTIONS WORKSHEET					
General Information			Site Information		
Analyst	AJR		Intersection	Buena Vista/El Moro	
Agency or Company	CEI		Jurisdiction	Maricopa County	
Date Performed	5/10/99		Analysis Year	1999	
Analysis Time Period	AM Peak				
Volume Adjustments					
		EB	WB	NB	SB
LT Traffic	Movement	v_1	v_4	v_7	v_{10}
	Volume, veh/h	247	103	143	254
	PHF	1.00	1.00	1.00	1.00
	Flow rate, veh/h	247	103	143	254
TH Traffic	Movement	v_2	v_5	v_8	v_{11}
	Volume, veh/h	308	393	207	94
	PHF	1.00	1.00	1.00	1.00
	Flow rate, veh/h	308	393	207	94
RT Traffic	Movement	v_3	v_6	v_9	v_{12}
	Volume, veh/h	105	123	77	152
	PHF	1.00	1.00	1.00	1.00
	Flow rate, veh/h	105	123	77	152
Approach Flow Computation					
Approach Flow (veh/h)			v_a (veh/h)		
$v_{a,E} = v_1 + v_2 + v_3$			660		
$v_{a,W} = v_4 + v_5 + v_6$			619		
$v_{a,N} = v_7 + v_8 + v_9$			427		
$v_{a,S} = v_{10} + v_{11} + v_{12}$			500		
Circulating Flow Computation					
Approach Flow (veh/h)			v_c (veh/h)		
$v_{c,E} = v_4 + v_{10} + v_{11}$			451		
$v_{c,W} = v_1 + v_7 + v_8$			597		
$v_{c,N} = v_1 + v_2 + v_{10}$			809		
$v_{c,S} = v_4 + v_5 + v_7$			639		
Capacity Computation					
		EB	WB	NB	SB
Capacity (Equation 17-70)	Upper bound	971	864	728	835
	Lower bound	788	693	573	667
v/c Ratio	Upper bound	0.680	0.716	0.587	0.599
	Lower bound	0.838	0.893	0.745	0.750

REFERENCES

PART A - TWSC UNSIGNALIZED INTERSECTIONS

1. Brilon, W., and M. Großmann. Aktualisiertes Berechnungsverfahren für Knotenpunkte ohne Lichtsignalanlagen. *Forschung Strassenbau und Strassenverkehrstechnik*, Heft 596, 1991.

2. *A Policy on Geometric Design of Highways and Streets*. American Association of State Highway and Transportation Officials, Washington, D.C., 1994.
3. *Manual on Uniform Traffic Control Devices*. U.S. Department of Transportation, 1988.
4. Kyte, M., Z. Tian, Z. Mir, Z. Hameedmansoor, W. Kittelson, M. Vandehey, B. Robinson, W. Brilon, L. Bondzio, N. Wu, and R. Troutbeck. *NCHRP Web Document 5: Capacity and Level of Service at Unsignalized Intersections: Final Report, Vol. 1—Two-Way Stop-Controlled Intersections*. 1997. <http://www.nap.edu/books/nch005/html>.
5. Troutbeck, R. *Estimating the Critical Acceptance Gap from Traffic Movements*. Research Report 92-5. Queensland University of Technology, Australia, March 1992.
6. Siegloch, W. Die Leistungsermittlung an Knotenpunkten ohne Lichtsignalsteuerung. *Forschung Strassenbau und Strassenverkehrstechnik*, Heft 154, 1973.
7. Harders, J. Die Leistungsfähigkeit nicht Signal geregelter Städtischer Verkehrsknoten. *Forschung Strassenbau und Strassenverkehrstechnik*, Heft 76, 1968.
8. Robertson, D. I. Coordinating Traffic Signals to Reduce Fuel Consumption. *Proceedings of the Royal Society Series A*, Vol. 387, No. 1792, 1983, pp. 1–19.
9. Yu, L., and M. Van Aerde. Implementing TRANSYT's Macroscopic Platoon Dispersion in Microscopic Traffic Simulation Models. Presented at 74th Annual Meeting of the Transportation Research Board, Washington, D.C., 1995.
10. Bonneson, J. A., and J. W. Fitts. Effect of Upstream Signal on Nonpriority Movement Capacity and Delay. In *Transportation Research Record 1572*, TRB, National Research Council, Washington, D.C., 1997, pp. 174–182.
11. Wu, N. An Approximation for the Distribution of Queue Lengths at Unsignalized Intersections. *Proc., Second International Symposium on Highway Capacity*, Vol. 2, Australian Road Research Board, Ltd., Aug. 1994.
12. Pline, J. (ed.). *Traffic Engineering Handbook*. Institute of Transportation Engineers, Prentice-Hall, Englewood Cliffs, N.J., 1992.

PART B - AWSC UNSIGNALIZED INTERSECTIONS

1. Kyte, M., Z. Tian, Z. Mir, Z. Hameedmansoor, W. Kittelson, M. Vandehey, B. Robinson, W. Brilon, L. Bondzio, N. Wu, and R. Troutbeck. *NCHRP Web Document 6: Capacity and Level of Service at Unsignalized Intersections: Final Report, Vol. 2—All-Way Stop-Controlled Intersections*. 1997. <http://www.nap.edu/books/nch006/html>.
2. Richardson, A. J. A Delay Model for Multiway Stop-Sign Intersections. In *Transportation Research Record 1112*, TRB, National Research Council, Washington, D.C., 1987, pp. 107–114.

PART C - ROUNDABOUTS

1. Kyte, M., Z. Tian, Z. Mir, Z. Hameedmansoor, W. Kittelson, M. Vandehey, B. Robinson, W. Brilon, L. Bondzio, N. Wu, and R. Troutbeck. *NCHRP Web Document 5: Capacity and Level of Service at Unsignalized Intersections: Final Report, Vol. 1—Two-Way Stop-Controlled Intersections*. 1997. <http://www.nap.edu/books/nch005/html>.
2. Brilon, W., and B. Stuwe. Capacity and Design of Traffic Circles in Germany. In *Transportation Research Record 1398*, TRB, National Research Council, Washington, D.C., 1993, pp. 61–67.
3. Troutbeck, R. J. Capacity and Design of Traffic Circles in Australia. In *Transportation Research Record 1398*, TRB, National Research Council, Washington, D.C., 1993, pp. 68–74.

4. Akcelik, R., and M. Besley. *SIDRA 5 User Guide*. ARRB Transport Research, Ltd., June 1996.
5. Flannery, A., and T. Datta. Operational Performance Measures of American Roundabouts. In *Transportation Research Record 1572*, TRB, National Research Council, Washington, D.C., 1997, pp. 68–75.
6. Troutbeck, R. Background for HCM Section on Analysis of Performance of Roundabouts. In *Transportation Research Record 1646*, TRB, National Research Council, Washington, D.C., 1998, pp. 54–62.

APPENDIX A. WORKSHEETS

PART A - TWSC UNSIGNALIZED INTERSECTIONS

WORKSHEET 1 - GEOMETRICS AND MOVEMENTS

WORKSHEET 2 - VOLUME ADJUSTMENTS

WORKSHEET 3 - SITE CHARACTERISTICS

WORKSHEET 4 - CRITICAL GAP AND FOLLOW-UP TIME

WORKSHEET 5 - EFFECT OF UPSTREAM SIGNALS

WORKSHEET 6 - IMPEDANCE AND CAPACITY CALCULATION

WORKSHEET 7 - EFFECT OF TWO-STAGE GAP ACCEPTANCE

WORKSHEET 8 - SHARED-LANE CAPACITY

WORKSHEET 9 - EFFECT OF FLARED MINOR-STREET APPROACHES

WORKSHEET 10 - CONTROL DELAY, QUEUE LENGTH, LEVEL OF SERVICE

WORKSHEET 11 - DELAY TO RANK 1 VEHICLES

PART B - AWSC UNSIGNALIZED INTERSECTIONS

WORKSHEET 1 - GEOMETRICS AND MOVEMENTS

WORKSHEET 2 - VOLUME ADJUSTMENTS AND LANE ASSIGNMENTS

WORKSHEET 3 - SATURATION HEADWAYS

WORKSHEET 4 - DEPARTURE HEADWAY AND SERVICE TIME

WORKSHEET 5 - CAPACITY AND LEVEL OF SERVICE

PART C - ROUNDABOUTS

ROUNDABOUT WORKSHEET

TWSC - UNSIGNALIZED INTERSECTIONS WORKSHEET

Worksheet 1

General Information

Analyst _____
 Agency or Company _____
 Date Performed _____
 Analysis Time Period _____

Site Information

Intersection _____
 Jurisdiction _____
 Analysis Year _____

Geometrics and Movements

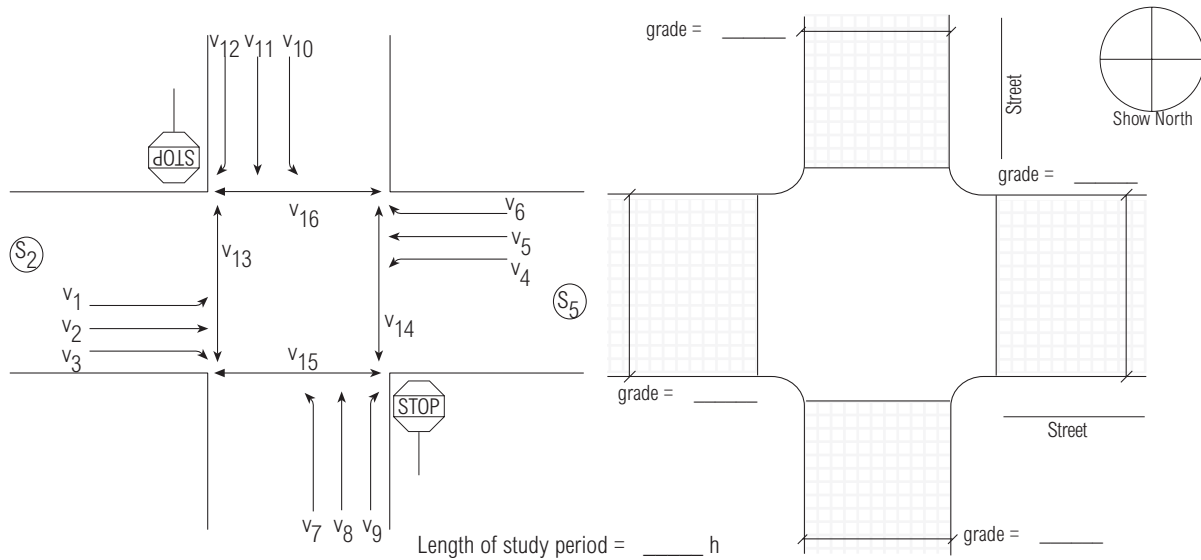

Worksheet 2

Vehicle Volumes and Adjustments

Movement	Vehicle Volumes and Adjustments											
	1	2	3	4	5	6	7	8	9	10	11	12
Volume (veh/h)												
Peak-hour factor, PHF												
Hourly flow rate (veh/h)												
Proportion of heavy vehicles, P_{HV}												

Pedestrian Volumes and Adjustments

Movement	13	14	15	16
Flow, V_x (ped/h)				
Lane width, w (ft)				
Walking speed, ¹ S_p (ft/s)				
Percent blockage, f_p (Equation 17-11)				

1. Default walking speed = 4.0 ft/s

TWSC - UNSIGNALIZED INTERSECTIONS WORKSHEET

Worksheet 3

General Information

Project Description _____

Lane Designation

Movements	Lane 1	Lane 2	Lane 3	Grade, G	Right Turn Channelized?
1, 2, 3					
4, 5, 6					
7, 8, 9					
10, 11, 12					

Flared Minor-Street Approach

Movement 9	<input type="checkbox"/> Yes	<input type="checkbox"/> No	Storage space, n	_____
				(number of vehicles)
Movement 12	<input type="checkbox"/> Yes	<input type="checkbox"/> No	Storage space, n	_____
				(number of vehicles)

Median Storage*

* Includes raised or striped median (RM), or two-way left-turn lane (TWLTL)

Type				
Movements 7 and 8	<input type="checkbox"/> Yes	_____	<input type="checkbox"/> No	Storage space, m _____
				(number of vehicles)
Movements 10 and 11	<input type="checkbox"/> Yes	_____	<input type="checkbox"/> No	Storage space, m _____
				(number of vehicles)

Upstream Signals

	Movements	Distance to Signal, D (ft)	Prog Speed, S_{prog} (mi/h)	Cycle Length, C (s)	Green Time, g_{eff} (s)	Arrival Type	Saturation Flow Rate, s (veh/h)	Progressed Flow, V_{prog} (veh/h)
S_2	protected LT					3		
	TH							
S_5	protected LT					3		
	TH							

Computing Delay to Major-Street Vehicles

Data for Computing Effect of Delay to Major-Street Vehicles	S_2 Approach	S_5 Approach
Shared-lane volume, major-street through vehicles, v_{11} , blocked by LT		
Shared-lane volume, major-street right-turn vehicles, v_{12} , blocked by LT		
Saturation flow rate, major-street through vehicles, s_{i1}		
Saturation flow rate, major-street right-turn vehicles, s_{i2}		
Number of major-street through lanes		
Length of study period, T (h)		

TWSC - UNSIGNALIZED INTERSECTIONS WORKSHEET

Worksheet 4

General Information

Project Description _____

Critical Gap and Follow-Up Time

$$t_c = t_{c,base} + t_{c,HV} P_{HV} + t_{c,G} G - t_{c,T} - t_{3,LT}$$

	Major LT		Minor RT		Minor TH		Minor LT	
Movement	1	4	9	12	8	11	7	10
$t_{c,base}$ (Exhibit 17-5)								
$t_{c,HV}$								
P_{HV} (from Worksheet 2)								
$t_{c,G}$	-	-	0.1	0.1	0.2	0.2	0.2	0.2
G (from Worksheet 3)								
$t_{3,LT}$								
$t_{c,T}$	single stage							
	two stage							
t_c (Equation 17-1)	single stage							
	two stage							

$$t_f = t_{f,base} + t_{f,HV} P_{HV}$$

	Major LT		Minor RT		Minor TH		Minor LT	
Movement	1	4	9	12	8	11	7	10
$t_{f,base}$ (Exhibit 17-5)								
$t_{f,HV}$								
P_{HV} (from Worksheet 2)								
t_f (Equation 17-2)								

Worksheet 5a

Time to Clear Standing Queue (Computation 1)

	Movement 2		Movement 5	
	$V_{T,prog}$	$V_{L,prot}$	$V_{T,prog}$	$V_{L,prot}$
Effective green, g_{eff} (s)				
Cycle length, C (s)				
Saturation flow rate, s (veh/h)				
Arrival type		3		3
v_{prog} (veh/h)				
R_p (from Chapter 16)		1.00		1.00
Proportion of vehicles arriving on green, P (Equation 17-17)				
g_{q1} (Equation 17-18)				
g_{q2} (Equation 17-19)				
g_q (Equation 17-20)				

TWSC - UNSIGNALIZED INTERSECTIONS WORKSHEET

Worksheet 5b

General Information

Project Description _____

Proportion of Time TWSC Intersection Is Blocked (Computation 2)

	Movement 2		Movement 5	
	$V_{T,prog}$	$V_{L,prot}$	$V_{T,prog}$	$V_{L,prot}$
α (Exhibit 17-13)				
$\beta = (1 + \alpha)^{-1}$				
$t_a = D/S_{prog}$ (s)				
$F = (1 + \alpha\beta t_a)^{-1}$				
$f = V_{prog}/V_c \geq 0$				
$V_{c,Max}$ (Equation 17-21)				
$V_{c,Min} = 1000N$				
t_p (Equation 17-22)				
p (Equation 17-23)				

Worksheet 5c

Platoon Event Periods (Computation 3)

p_2 (from Worksheet 5b)			
p_5 (from Worksheet 5b)			
p_{dom} (Equation 17-24)			
p_{subo} (Equation 17-25)			
Constrained or unconstrained (Equation 17-26, 17-27)			
Proportion for Minor Movements, p_x			
	Single-Stage (Exhibit 17-16)	Two-Stage	
		Stage I	Stage II
p_1			
p_4			
p_7		$1 - p_2$	$1 - p_5$
p_8		$1 - p_2$	$1 - p_5$
p_9			
p_{10}		$1 - p_5$	$1 - p_2$
p_{11}		$1 - p_5$	$1 - p_2$
p_{12}			

TWSC - UNSIGNALIZED INTERSECTIONS WORKSHEET

Worksheet 5d

General Information

Project Description _____

Conflicting Flows During Unblocked Period (Computation 4)

Single-Stage

Movements	1	4	7	8	9	10	11	12
$v_{c,x}$ (Exhibit 17-4)								
s (veh/h)								
p_x (from Worksheet 5c)								
$v_{c,u,x}$ (Equation 17-28)								

Two-Stage

Movements	7		8		10		11	
	Stage I	Stage II	Stage I	Stage II	Stage I	Stage II	Stage I	Stage II
$v_{c,x}$ (Exhibit 17-4)								
s (veh/h)								
p_x (from Worksheet 5c)								
$V_{c,u,x}$ (Equation 17-28)								

Worksheet 5e

Capacity During Unblocked Period (Computation 5)

Single-Stage

Movements	1	4	7	8	9	10	11	12
p_x (from Worksheet 5c)								
$c_{r,x}$ (Equation 17-3)								
$c_{plat,x}$ (Equation 17-29)								

Two-Stage

Movements	7		8		10		11	
	Stage I	Stage II	Stage I	Stage II	Stage I	Stage II	Stage I	Stage II
p_x (from Worksheet 5c)								
$c_{r,x}$ (Equation 17-3)								
$c_{plat,x}$ (Equation 17-29)								

TWSC - UNSIGNALIZED INTERSECTIONS WORKSHEET		
Worksheet 6		
General Information		
Project Description _____		
Impedance and Capacity Calculation		
Step 1: RT from Minor Street	v_9	v_{12}
Conflicting flows (Exhibit 17-4)	$v_{c,9} =$	$v_{c,12} =$
Potential capacity (Equation 17-3 or 17-29)	$c_{p,9} =$	$c_{p,12} =$
Ped impedance factor (Equation 17-12)	$p_{p,9} =$	$p_{p,12} =$
Movement capacity (Equation 17-4)	$c_{m,9} = c_{p,9} p_{p,9} =$	$c_{m,12} = c_{p,12} p_{p,12} =$
Prob of queue-free state (Equation 17-5)	$p_{0,9} =$	$p_{0,12} =$
Step 2: LT from Major Street	v_4	v_1
Conflicting flows (Exhibit 17-4)	$v_{c,4} =$	$v_{c,1} =$
Potential capacity (Equation 17-3 or 17-29)	$c_{p,4} =$	$c_{p,1} =$
Ped impedance factor (Equation 17-12)	$p_{p,4} =$	$p_{p,1} =$
Movement capacity (Equation (17-4)	$c_{m,4} = c_{p,4} p_{p,4} =$	$c_{m,1} = c_{p,1} p_{p,1} =$
Prob of queue-free state (Equation 17-5)	$p_{0,4} =$	$p_{0,1} =$
Major left shared lane prob of queue-free state (Equation 17-16)	$p_{0,4}^* =$	$p_{0,1}^* =$
Step 3: TH from Minor Street (4-leg intersections only)	v_8	v_{11}
Conflicting flows (Exhibit 17-4)	$v_{c,8} =$	$v_{c,11} =$
Potential capacity (Equation 17-3 or 17-29)	$c_{p,8} =$	$c_{p,11} =$
Ped impedance factor (Equation 17-12)	$p_{p,8} =$	$p_{p,11} =$
Capacity adjustment factor due to impeding movement (shared lane use p^*) (Equation 17-13)	$f_8 = p_{0,4} p_{0,1} p_{p,8} =$	$f_{11} = p_{0,4} p_{0,1} p_{p,11} =$
Movement capacity (Equation 17-7)	$c_{m,8} = c_{p,8} f_8 =$	$c_{m,11} = c_{p,11} f_{11} =$
Prob of queue-free state	$p_{0,8} =$	$p_{0,11} =$
Step 4: LT from Minor Street (4-leg intersections only)	v_7	v_{10}
Conflicting flows (Exhibit 17-4)	$v_{c,7} =$	$v_{c,10} =$
Potential capacity (Equation 17-3 or 17-29)	$c_{p,7} =$	$c_{p,10} =$
Ped impedance factor (Equation 17-12)	$p_{p,7} =$	$p_{p,10} =$
Major left, minor through impedance factor	$p_7'' = p_{0,11} f_{11} =$	$p_{10}'' = p_{0,8} f_8 =$
Major left, minor through adjusted impedance factor (Equation 17-8)	$p_7' =$	$p_{10}' =$
Capacity adjustment factor due to impeding movements (Equation 17-14)	$f_7 = p_7' p_{0,12} p_{p,7} =$	$f_{10} = p_{10}' p_{0,9} p_{p,10} =$
Movement capacity (Equation 17-10)	$c_{m,7} = f_7 c_{p,7} =$	$c_{m,10} = f_{10} c_{p,10} =$
Step 5: LT from Minor Street (T-intersections only)	v_7	v_{10}
Conflicting flows (Exhibit 17-4)	$v_{c,7} =$	$v_{c,10} =$
Potential capacity (Equation 17-3 or 17-29)	$c_{p,7} =$	$c_{p,10} =$
Ped impedance factor (Equation 17-12)	$p_{p,7} =$	$p_{p,10} =$
Capacity adjustment factor due to impeding movement (shared lane use p^*) (Equation 17-13)	$f_7 = p_{0,4} p_{0,1} p_{p,7} =$	$f_{10} = p_{0,4} p_{0,1} p_{p,10} =$
Movement capacity (Equation 17-7)	$c_{m,7} = c_{p,7} f_7 =$	$c_{m,10} = c_{p,10} f_{10} =$
Notes		
1. For 4-leg intersections use Steps 1, 2, 3, and 4.		
2. For T-intersections use Steps 1, 2, and 5.		

TWSC - UNSIGNALIZED INTERSECTIONS WORKSHEET

Worksheet 7a

General Information

Project Description _____

Effect of Two-Stage Gap Acceptance

Step 3: TH from Minor Street	V_8	V_{11}
Part I - First Stage		
Conflicting flows (Exhibit 17-4)	$V_{c,I,8} =$	$V_{c,I,11} =$
Potential capacity (Equation 17-3 or 17-29)	$C_{p,I,8} =$	$C_{p,I,11} =$
Ped impedance factor (Equation 17-12)	$P_{p,I,8} =$	$P_{p,I,11} =$
Capacity adjustment factor due to impeding movement (shared lane use p^*) (Equation 17-6 or 17-13)	$f_{I,8} = P_{0,1} P_{p,I,8} =$	$f_{I,11} = P_{0,4} P_{p,I,11} =$
Movement capacity (Equation 17-7)	$C_{m,I,8} = C_{p,I,8} f_{I,8} =$	$C_{m,I,11} = C_{p,I,11} f_{I,11} =$
Prob of queue-free state (Equation 17-5)	$P_{0,I,8} =$	$P_{0,I,11} =$
Part II - Second Stage		
Conflicting flows (Exhibit 17-4)	$V_{c,II,8} =$	$V_{c,II,11} =$
Potential capacity (Equation 17-3 or 17-29)	$C_{p,II,8} =$	$C_{p,II,11} =$
Ped impedance factor (Equation 17-12)	$P_{p,II,8} =$	$P_{p,II,11} =$
Capacity adjustment factor due to impeding movement (shared lane use p^*) (Equation 17-6 or 17-13)	$f_{II,8} = P_{0,4} P_{p,II,8} =$	$f_{II,11} = P_{0,1} P_{p,II,11} =$
Movement capacity (Equation 17-7)	$C_{m,II,8} = C_{p,II,8} f_{II,8} =$	$C_{m,II,11} = C_{p,II,11} f_{II,11} =$
Prob of queue-free state (Equation 17-5)	$P_{0,II,8} =$	$P_{0,II,11} =$
Part III - Single Stage		
Conflicting flows (Exhibit 17-4)	$V_{c,8} =$	$V_{c,11} =$
Potential capacity (Equation 17-3 or 17-29)	$C_{p,8} =$	$C_{p,11} =$
Ped impedance factor (Equation 17-12)	$P_{p,8} =$	$P_{p,11} =$
Capacity adjustment factor due to impeding movement (shared lane use p^*) (Equation 17-13 or 17-16)	$f_8 = P_{0,4} P_{0,1} P_{p,8} =$	$f_{11} = P_{0,4} P_{0,1} P_{p,11} =$
Movement capacity (Equation 17-7)	$C_{m,8} = C_{p,8} f_8 =$	$C_{m,11} = C_{p,11} f_{11} =$
Result for Two-Stage Process		
a (Equation 17-30)	a =	a =
y (Equation 17-31)	y =	y =
c_T (Equation 17-32 or 17-33)	$c_T =$	$c_T =$
Prob of queue-free state (Equation 17-5)	$P_{0,8} =$	$P_{0,11} =$

TWSC - UNSIGNALIZED INTERSECTIONS WORKSHEET

Worksheet 7b

General Information

Project Description _____

Effect of Two-Stage Gap Acceptance

Step 4: LT from Minor Street	V_7	V_{10}
Part I - First Stage		
Conflicting flows (Exhibit 17-4)	$V_{c,I,7} =$	$V_{c,I,10} =$
Potential capacity (Equation 17-3 or 17-29)	$C_{p,I,7} =$	$C_{p,I,10} =$
Ped impedance factor (Equation 17-12)	$P_{p,I,7} =$	$P_{p,I,10} =$
Capacity adjustment factor due to impeding movements	$f_{I,7} = P_{0,1} P_{p,I,7} =$	$f_{I,10} = P_{0,4} P_{p,I,10} =$
Movement capacity (Equation 17-7)	$C_{m,I,7} = f_{I,7} C_{p,I,7} =$	$C_{m,I,10} = f_{I,10} C_{p,I,10} =$
Part II - Second Stage		
Conflicting flows (Exhibit 17-4)	$V_{c,II,7} =$	$V_{c,II,10} =$
Potential capacity (Equation 17-3 or 17-29)	$C_{p,II,7} =$	$C_{p,II,10} =$
Ped impedance factor (Equation 17-12)	$P_{p,II,7} =$	$P_{p,II,10} =$
Capacity adjustment factor due to impeding movements	$f_{II,7} = P_{0,4} P_{0,11} P_{0,12} P_{p,II,7} =$	$f_{II,10} = P_{0,1} P_{0,1,8} P_{0,9} P_{p,II,10} =$
Movement capacity (Equation 17-7)	$C_{m,II,7} = f_{II,7} C_{p,II,7} =$	$C_{m,II,10} = f_{II,10} C_{p,II,10} =$
Part III - Single-Stage		
Conflicting flows (Exhibit 17-4)	$V_{c,7} =$	$V_{c,10} =$
Potential capacity (Equation 17-3 or 17-29)	$C_{p,7} =$	$C_{p,10} =$
Ped impedance factor (Equation 17-12)	$P_{p,7} =$	$P_{p,10} =$
Major left, minor through impedance factor	$P_7^* = P_{0,11} f_{11} =$	$P_{10}^* = P_{0,8} f_8 =$
Major left, minor through adjusted impedance factor (Equation 17-8)	$P_7' =$	$P_{10}' =$
Capacity adjustment factor due to impeding movements (Equation 17-9 or 17-14)	$f_7 = P_7' P_{0,12} P_{p,7} =$	$f_{10} = P_{10}' P_{0,9} P_{p,10} =$
Movement capacity (Equation 17-7)	$C_{m,7} = f_7 C_{p,7} =$	$C_{m,10} = f_{10} C_{p,10} =$
Result for Two-Stage Process		
a (Equation 17-30)	a =	a =
y (Equation 17-31)	y =	y =
c_T (Equation 17-32 or 17-33)	$C_T =$	$C_T =$

TWSC - UNSIGNALIZED INTERSECTIONS WORKSHEET

Worksheet 8

General Information

Project Description _____

Shared-Lane Capacity

$$c_{SH} = \frac{\sum_y v_y}{\sum_y \left(\frac{v_y}{c_{m,y}} \right)} \quad (\text{Equation 17-15})$$

Lane	v (veh/h)			c _m (veh/h)			c _{SH} (veh/h)
	Movement 7	Movement 8	Movement 9	Movement 7	Movement 8	Movement 9	
1							
2							
3							
	Movement 10	Movement 11	Movement 12	Movement 10	Movement 11	Movement 12	
1							
2							
3							

Worksheet 9

Effect of Flared Minor-Street Approaches

	Lane _____			Lane _____		
	Movement 7	Movement 8	Movement 9	Movement 10	Movement 11	Movement 12
c _{sep} (from Worksheet 6 or 7)						
volume (from Worksheet 2)						
delay (Equation 17-38)						
Q _{sep} (Equation 17-34)						
Q _{sep} + 1						
round (Q _{sep} + 1)						
n _{max} (Equation 17-35)						
c _{SH}						
c _{sep}						
n						
c _{act} (Equation 17-36)						

TWSC - UNSIGNALIZED INTERSECTIONS WORKSHEET

Worksheet 10

General Information

Project Description _____

Control Delay, Queue Length, Level of Service

Lane	v (veh/h)	c _m (veh/h)	v/c	Queue Length (Equation 17-37)	Control Delay (Equation 17-38)	LOS (Exhibit 17-2)	Delay and LOS
1 (7) (8) (9)							
2 (7) (8) (9)							
3 (7) (8) (9)							
1 (10) (11) (12)							
2 (10) (11) (12)							
3 (10) (11) (12)							

Movement	v (veh/h)	c _m (veh/h)	v/c	Queue Length (Equation 17-37)	Control Delay (Equation 17-38)	LOS (Exhibit 17-2)
1						
4						

Worksheet 11

Delay to Rank 1 Vehicles

	S ₂ Approach	S ₅ Approach
p _{0,j} (Equation 17-5)	p _{0,1} =	p _{0,4} =
v _{i1} , volume for Stream 2 or 5		
v _{i2} , volume for Stream 3 or 6		
s _{i1} , saturation flow rate for Stream 2 or 5		
s _{i2} , saturation flow rate for Stream 3 or 6		
p _{0,j} [*] (Equation 17-16)	p _{0,1} [*] =	p _{0,4} [*] =
d _{major left} , delay for Stream 1 or 4		
N, number of major-street through lanes		
d _{Rank 1} , delay for Stream 2 or 5 (Equation 17-39)		

AWSC - UNSIGNALIZED INTERSECTIONS WORKSHEET

Worksheet 1

General Information	Site Information
Analyst _____	Intersection _____
Agency or Company _____	Jurisdiction _____
Date Performed _____	Analysis Year _____
Analysis Time Period _____	

Geometrics and Movements

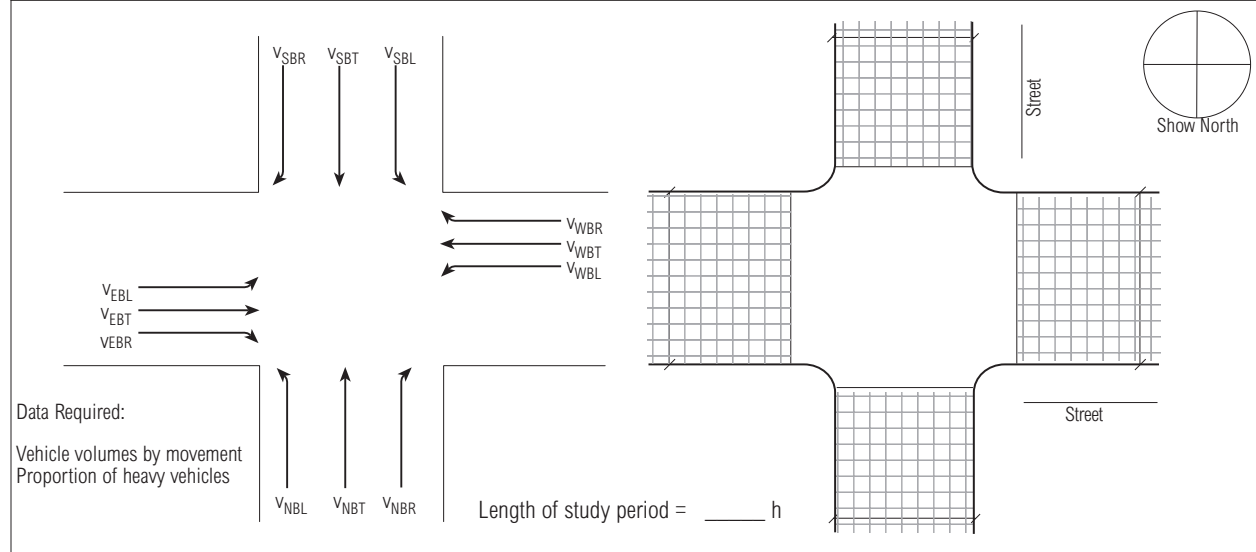

Worksheet 2

Volume Adjustments and Lane Assignments

Approach		Lane 1			Lane 2			Geometry Group (Exhibit 17-32)
		LT	TH	RT	LT	TH	RT	
EB	Volume (veh/h)							
	PHF							
	% Heavy vehicle							
	Flow rate (veh/h)							
WB	Volume (veh/h)							
	PHF							
	% Heavy vehicle							
	Flow rate (veh/h)							
NB	Volume (veh/h)							
	PHF							
	% Heavy vehicle							
	Flow rate (veh/h)							
SB	Volume (veh/h)							
	PHF							
	% Heavy vehicle							
	Flow rate (veh/h)							

AWSC - UNSIGNALIZED INTERSECTIONS WORKSHEET

Worksheet 3

General Information

Project Description _____

Saturation Headways

	EB		WB		NB		SB	
	L1	L2	L1	L2	L1	L2	L1	L2
Total lane flow rate								
Left-turn flow rate in lane								
Right-turn flow rate in lane								
Proportion LT in lane								
Proportion RT in lane								
Proportion HV in lane								
h_{LT-adj} (Exhibit 17-33)								
h_{RT-adj} (Exhibit 17-33)								
h_{HV-adj} (Exhibit 17-33)								
h_{adj} (Equation 17-56)								

Worksheet 4a

Departure Headway

	EB		WB		NB		SB	
	L1	L2	L1	L2	L1	L2	L1	L2
Total lane flow rate								
h_d , initial value (s)	3.2	3.2	3.2	3.2	3.2	3.2	3.2	3.2
x , initial value (Equation 17-57)								
h_d , Iteration 1								
h_d , difference								
h_d , Iteration 2								
h_d , difference								
h_d , Iteration 3								
h_d , difference								
h_d , Iteration 4								
h_d , difference								
h_d , Iteration 5								
h_d , difference								
Convergence?								
h_d , final								
x , final								

AWSC - UNSIGNALIZED INTERSECTIONS WORKSHEET

Worksheet 4b

Project Description _____

Service Time												
i	$P(a_{01})$	$P(a_{02})$	$P(a_{CL1})$	$P(a_{CL2})$	$P(a_{CR1})$	$P(a_{CR2})$	$P(i)$	Adj $P(i)$	$P'(i)$	h_{base}	h_{adj}	h_{si}
1												
2												
3												
4												
5												
6												
7												
8												
9												
10												
11												
12												
13												
14												
15												
16												
17												
18												
19												
20												
21												
22												
23												
24												
25												
26												
27												
28												
29												
30												
31												
32												
33												
34												
35												
36												
37												
38												
39												
40												
41												
42												
43												
44												
45												
46												
47												
48												
49												
50												
51												
52												
53												
54												
55												
56												
57												
58												
59												
60												
61												
62												
63												
64												

AWSC - UNSIGNALIZED INTERSECTIONS WORKSHEET

Worksheet 5

General Information

Project Description _____

Capacity and Level of Service

	EB		WB		NB		SB	
	L1	L2	L1	L2	L1	L2	L1	L2
Total lane flow rate (veh/h)								
Departure headway, h_d (s)								
Degree of utilization, x								
Move-up time, m (s)								
Service time, t_s (s)								
Capacity (veh/h)								
Delay (s) (Equation 17-55)								
Level of service (Exhibit 17-22)								
Delay, approach (s/veh)								
Level of service, approach								
Delay, intersection (s/veh)								
Level of service, intersection								

ROUNDBABOUTS - UNSIGNALIZED INTERSECTIONS WORKSHEET

General Information		Site Information			
Analyst _____	Intersection _____				
Agency or Company _____	Jurisdiction _____				
Date Performed _____	Analysis Year _____				
Analysis Time Period _____					
Volume Adjustments					
		EB	WB	NB	SB
LT Traffic	Movement	v ₁	v ₄	v ₇	v ₁₀
	Volume, veh/h				
	PHF				
	Flow rate, veh/h				
TH Traffic	Movement	v ₂	v ₅	v ₈	v ₁₁
	Volume, veh/h				
	PHF				
	Flow rate, veh/h				
RT Traffic	Movement	v ₃	v ₆	v ₉	v ₁₂
	Volume, veh/h				
	PHF				
	Flow rate, veh/h				
Approach Flow Computation					
Approach Flow (veh/h)		v _a (veh/h)			
$v_{a,E} = v_1 + v_2 + v_3$					
$v_{a,W} = v_4 + v_5 + v_6$					
$v_{a,N} = v_7 + v_8 + v_9$					
$v_{a,S} = v_{10} + v_{11} + v_{12}$					
Circulating Flow Computation					
Approach Flow (veh/h)		v _c (veh/h)			
$v_{c,E} = v_4 + v_{10} + v_{11}$					
$v_{c,W} = v_1 + v_7 + v_8$					
$v_{c,N} = v_1 + v_2 + v_{10}$					
$v_{c,S} = v_4 + v_5 + v_7$					
Capacity Computation					
		EB	WB	NB	SB
Capacity (Equation 17-70)	Upper bound				
	Lower bound				
v/c Ratio	Upper bound				
	Lower bound				